

NARROW-PITCH CONNECTORS FOR BOARD-TO-FPC CONNECTION

NARROW PITCH (0.4mm) CONNECTORS F4

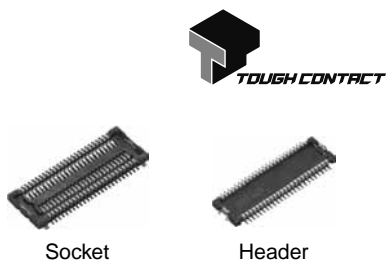

Compliance with RoHS Directive

2. Strong resistance to adverse environments! Utilizes *TOUGH CONTACT* construction for high contact reliability.
(See Page 6 for details of the structure)

3. Improved mating strength between the socket and header
The simple locking structures provided for the soldering terminals and the contact points improve the mating strength and provide tactile feedback when locked.

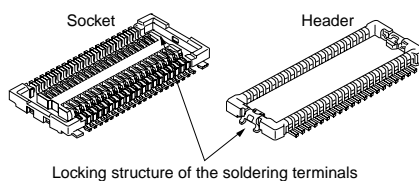

4. Easy to design product circuits
1) An insulating wall provided for the bottom surface of the connector prevents contact between the pattern on the PC board and the metal pins, enabling pattern wiring under the connector, and thus contributing to the reduction in size of PC boards.

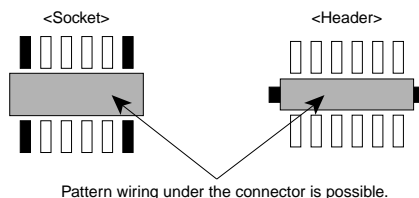

5. Connectors for inspection available
Connectors for inspection are available that are ideal for modular unit inspection and inspection in device assembly processes.

APPLICATIONS

Compact portable devices “Cellular phones, DVD, DSC, etc”

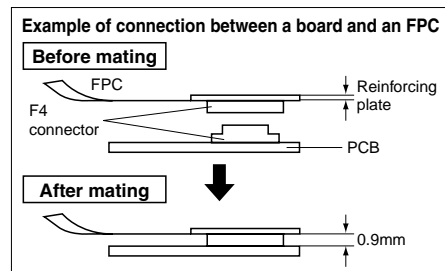

FEATURES

1. The lowest profile class among two-piece connectors in the world (Mated height: 0.9mm)

Achieved both a 0.4 mm pitch and an ultra low profile of 0.9 mm high when mated, contributing to further thickness reduction of products.

AXK7L, 8L

ORDERING INFORMATION

| | | | | | | | |
|------------|--|--|--|--|--|--|----------|
| AXK | | | | | | | G |
|------------|--|--|--|--|--|--|----------|

AXK: Narrow Pitch Connector Series

Series name;
7L: F4 (0.4 mm pitch) Socket
8L: F4 (0.4 mm pitch) Header

Number of contacts (2 digits)

Mated height
<Socket>
2: For mated height 0.9 mm
<Header>
1: For mated height 0.9 mm

Functions
2: Without positioning bosses

Surface treatment (Contact portion / Terminal portion) ^{Note 2}
<Socket>
7: Ni plating on base, Au plating on surface (for Ni barrier available)
<Header>
5: Ni plating on base, Au plating on surface

Other specifications
<Header>
B: Soldering terminals with fork type terminal ^{Note 1}

Packing
G: 3,000 pieces embossed tape and plastic reel × 2

- Notes: 1. "B" in the 11th digit of the header part number signifies a fork type soldering terminals to lessen the constraint on amount of solder when mounting, and a construction that makes it difficult when mounting for excess solder to interfere with the socket.
Although compatible with the previous parts, these parts are not compatible with the recommended PC board pattern and recommended metal mask pattern.
2. The part number will be changed as follows due to the change in the plating specifications for the metal clips.
This change will apply to production from December 2009 onwards. (There will be no change to the contact portion and terminal portion.)
(Socket)
3: Ni plating on base, Au plating on surface (for Ni barrier available)
(Header)
4: Ni plating on base, Au plating on surface

PRODUCT TYPES 

| Mated height | Number of contacts | Part number | | | | Packing | |
|--------------|--------------------|-------------|---|--------------|---|-----------------------|------------------------|
| | | Socket | Socket Products with plating change to soldering terminals (in effect from Dec. '09) | Header | Header Products with plating change to soldering terminals (in effect from Dec. '09) | Inner carton (1 reel) | Outer carton |
| 0.9 mm | 10 | AXK7L10227G | AXK7L10223G | AXK8L10125BG | AXK8L10124BG | 3,000 pieces | 6,000 pieces (2 reels) |
| | 12 | AXK7L12227G | AXK7L12223G | AXK8L12125BG | AXK8L12124BG | | |
| | 14 | AXK7L14227G | AXK7L14223G | AXK8L14125BG | AXK8L14124BG | | |
| | 16 | AXK7L16227G | AXK7L16223G | AXK8L16125BG | AXK8L16124BG | | |
| | 20 | AXK7L20227G | AXK7L20223G | AXK8L20125BG | AXK8L20124BG | | |
| | 22 | AXK7L22227G | AXK7L22223G | AXK8L22125BG | AXK8L22124BG | | |
| | 24 | AXK7L24227G | AXK7L24223G | AXK8L24125BG | AXK8L24124BG | | |
| | 26 | AXK7L26227G | AXK7L26223G | AXK8L26125BG | AXK8L26124BG | | |
| | 28 | AXK7L28227G | AXK7L28223G | AXK8L28125BG | AXK8L28124BG | | |
| | 30 | AXK7L30227G | AXK7L30223G | AXK8L30125BG | AXK8L30124BG | | |
| | 32 | AXK7L32227G | AXK7L32223G | AXK8L32125BG | AXK8L32124BG | | |
| | 34 | AXK7L34227G | AXK7L34223G | AXK8L34125BG | AXK8L34124BG | | |
| | 36 | AXK7L36227G | AXK7L36223G | AXK8L36125BG | AXK8L36124BG | | |
| | 38 | AXK7L38227G | AXK7L38223G | AXK8L38125BG | AXK8L38124BG | | |
| | 40 | AXK7L40227G | AXK7L40223G | AXK8L40125BG | AXK8L40124BG | | |
| | 44 | AXK7L44227G | AXK7L44223G | AXK8L44125BG | AXK8L44124BG | | |
| | 48 | AXK7L48227G | AXK7L48223G | AXK8L48125BG | AXK8L48124BG | | |
| | 50 | AXK7L50227G | AXK7L50223G | AXK8L50125BG | AXK8L50124BG | | |
| 54 | AXK7L54227G | AXK7L54223G | AXK8L54125BG | AXK8L54124BG | | | |
| 60 | AXK7L60227G | AXK7L60223G | AXK8L60125BG | AXK8L60124BG | | | |
| 66 | AXK7L66227G | AXK7L66223G | AXK8L66125BG | AXK8L66124BG | | | |
| 70 | AXK7L70227G | AXK7L70223G | AXK8L70125BG | AXK8L70124BG | | | |
| 80 | AXK7L80227G | AXK7L80223G | AXK8L80125BG | AXK8L80124BG | | | |

- Notes: 1. Regarding ordering units;
 During production: Please make orders in 1-reel units.
 Samples for mounting confirmation: Available in units of 50 pieces. Please contact us.
 Samples: Available. Please contact us.
2. The above part numbers are for connectors without positioning bosses, which are standard. When ordering connectors with positioning bosses, please contact our sales office.
3. Please contact us regarding different number of contacts.
4. "B" in the 11th digit of the header part number signifies a fork type soldering terminals to lessen the constraint on amount of solder when mounting, and a construction that makes it difficult when mounting for excess solder to interfere with the socket.
 Although compatible with the previous parts, these parts are not compatible with the recommended PC board pattern and recommended metal mask pattern.
5. Since the plating specifications for the metal clips will be changed starting with production in December 2009 onwards, the digit "7" in the 10th place of the part number for sockets will be changed to "3", and "5" for headers will be changed to "4".
 Be careful when placing an order.

SPECIFICATIONS

1. Characteristics

| | Item | Specifications | Conditions |
|---|--|--|---|
| Electrical characteristics | Rated current | 0.3A/terminal (Max. 5 A at total terminals) | — |
| | Rated voltage | 60V AC/DC | — |
| | Breakdown voltage | 150V AC for 1 min. | Rated voltage is applied for one minute and check for short circuit or damage with a detection current of 1mA |
| | Insulation resistance | Min. 1,000MΩ (Initial) | Using 250V DC megger (applied for 1 min.) |
| | Contact resistance | Max. 90mΩ | Based on the contact resistance measurement method specified by JIS C 5402. |
| Environmental characteristics | Ambient temperature | -55°C to +85°C | No freezing at low temperatures |
| | Soldering heat resistance | Max. peak temperature of 260°C (on the surface of the PC board around the connector terminals) | Infrared reflow soldering |
| | | 300°C within 5 sec, 350°C within 3 sec. | Soldering iron |
| | Storage temperature | -55°C to +85°C (Product only) -40°C to +50°C (Emboss packing) | No freezing at low temperatures |
| | Thermal shock resistance (header and socket mated) | 5 cycles, insulation resistance min. 100MΩ, contact resistance max. 90mΩ | Sequence 1. -55 [±] 3°C, 30 min. 2. ~, Max. 5 min. 3. 85 [±] 3°C, 30 min. 4. ~, Max. 5 min. |
| | Humidity resistance (header and socket mated) | 120 hours, insulation resistance min. 100MΩ, contact resistance max. 90mΩ | Temperature 40±2°C, humidity 90 to 95% R.H. |
| | Saltwater spray resistance (header and socket mated) | 24 hours, insulation resistance min. 100MΩ, contact resistance max. 90mΩ | Temperature 35±2°C, saltwater concentration 5±1% |
| H ₂ S resistance (header and socket mated) | 48 hours, contact resistance max. 90mΩ | Temperature 40±2°C, gas concentration 3±1 ppm, humidity 75 to 80% R.H. | |
| Lifetime characteristics | Insertion and removal life | 50 times | Repeated insertion and removal speed of max. 200 times/hours |
| Unit weight | | 20 contacts; Socket: 0.03g Header: 0.01g | — |

AXK7L, 8L

2. Material and surface treatment

| Part name | Material | Surface treatment |
|----------------|---------------------|---|
| Molded portion | LCP resin (UL94V-0) | — |
| Contact/Post | Copper alloy | Contact portion: Ni plating on base, Au plating on surface Terminal portion: Ni plating on base, Au plating on surface (Except for front edge of terminal) However, the area adjacent to the socket terminal is exposed to Ni on base. Metal clips ^{Note)} : Ni plating on base, Sn plating on surface (Socket: except for front edge of the terminal) |

Note: The following change will apply to production from December 2009 onwards.

Socket: Ni plating on base, Pd + Au flash plating on surface (Expect for front edge of terminal)

Header: Ni plating on base, Au plating on surface (Expect for front edge of terminal)

DIMENSIONS (unit: mm)

The CAD data of the products with a **CAD Data** mark can be downloaded from: <http://panasonic-electric-works.net/ac>

• Socket (Mated height 0.9 mm)

CAD Data

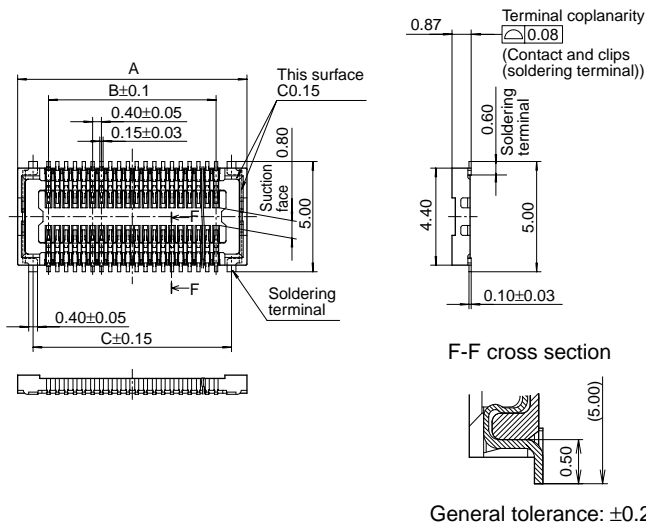

General tolerance: ±0.2

Dimension table (mm)

| Number of contacts/ Dimensions | A | B | C |
|-----------------------------------|------|------|------|
| 10 | 4.4 | 1.6 | 3.0 |
| 12 | 4.8 | 2.0 | 3.4 |
| 14 | 5.2 | 2.4 | 3.8 |
| 16 | 5.6 | 2.8 | 4.2 |
| 20 | 6.4 | 3.6 | 5.0 |
| 22 | 6.8 | 4.0 | 5.4 |
| 24 | 7.2 | 4.4 | 5.8 |
| 26 | 7.6 | 4.8 | 6.2 |
| 28 | 8.0 | 5.2 | 6.6 |
| 30 | 8.4 | 5.6 | 7.0 |
| 32 | 8.8 | 6.0 | 7.4 |
| 34 | 9.2 | 6.4 | 7.8 |
| 36 | 9.6 | 6.8 | 8.2 |
| 38 | 10.0 | 7.2 | 8.6 |
| 40 | 10.4 | 7.6 | 9.0 |
| 44 | 11.2 | 8.4 | 9.8 |
| 48 | 12.0 | 9.2 | 10.6 |
| 50 | 12.4 | 9.6 | 11.0 |
| 54 | 13.2 | 10.4 | 11.8 |
| 60 | 14.4 | 11.6 | 13.0 |
| 66 | 15.6 | 12.8 | 14.2 |
| 70 | 16.4 | 13.6 | 15.0 |
| 80 | 18.4 | 15.6 | 17.0 |

• Header (Mated height: 0.9 mm)

CAD Data

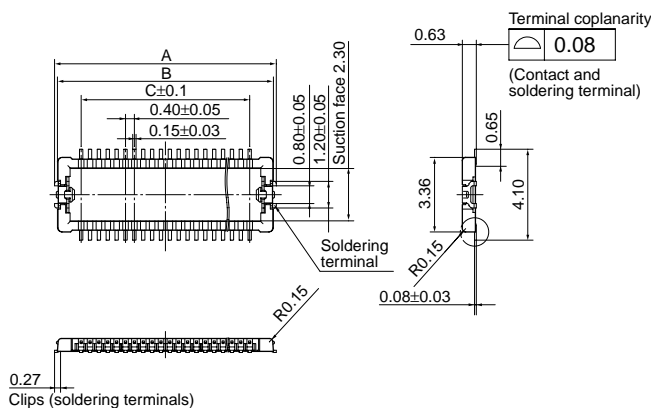

General tolerance: ±0.2

Dimension table (mm)

| Number of contacts/ Dimensions | A | B | C |
|-----------------------------------|------|-------|------|
| 10 | 4.0 | 3.74 | 1.6 |
| 12 | 4.4 | 4.14 | 2.0 |
| 14 | 4.8 | 4.54 | 2.4 |
| 16 | 5.2 | 4.94 | 2.8 |
| 20 | 6.0 | 5.74 | 3.6 |
| 22 | 6.4 | 6.14 | 4.0 |
| 24 | 6.8 | 6.54 | 4.4 |
| 26 | 7.2 | 6.94 | 4.8 |
| 28 | 7.6 | 7.34 | 5.2 |
| 30 | 8.0 | 7.74 | 5.6 |
| 32 | 8.4 | 8.14 | 6.0 |
| 34 | 8.8 | 8.54 | 6.4 |
| 36 | 9.2 | 8.94 | 6.8 |
| 38 | 9.6 | 9.34 | 7.2 |
| 40 | 10.0 | 9.74 | 7.6 |
| 44 | 10.8 | 10.54 | 8.4 |
| 48 | 11.6 | 11.34 | 9.2 |
| 50 | 12.0 | 11.74 | 9.6 |
| 54 | 12.8 | 12.54 | 10.4 |
| 60 | 14.0 | 13.74 | 11.6 |
| 66 | 15.2 | 14.94 | 12.8 |
| 70 | 16.0 | 15.74 | 13.6 |
| 80 | 18.0 | 17.74 | 15.6 |

• Socket and header are mated

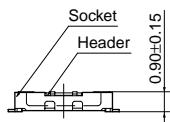

EMBOSSED TAPE DIMENSIONS (unit: mm) (Common for respective contact type, socket and header)

Tape dimensions (Conforming to JIS C 0806-1990. However, some tapes have mounting hole pitches that do not comply with the standard.)

Plastic reel dimensions (Conforming to EIAJ ET-7200B)

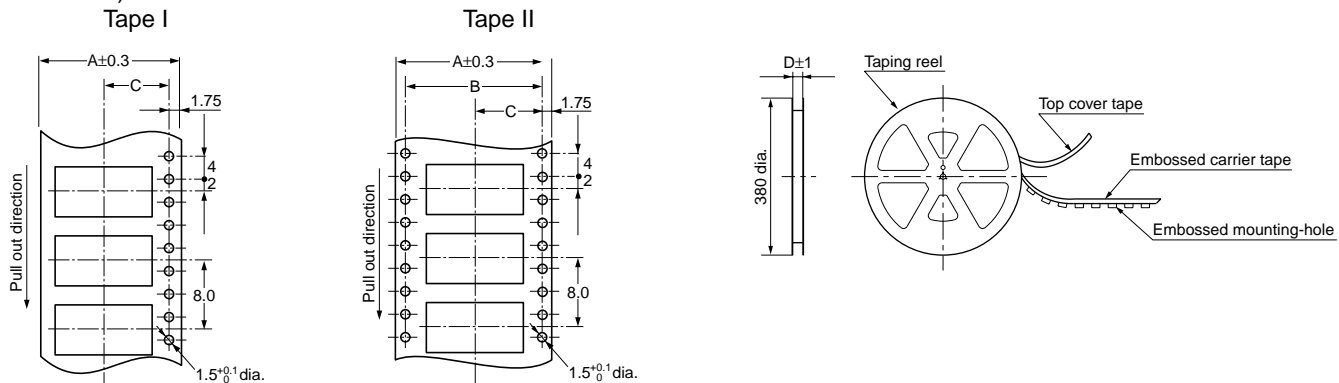
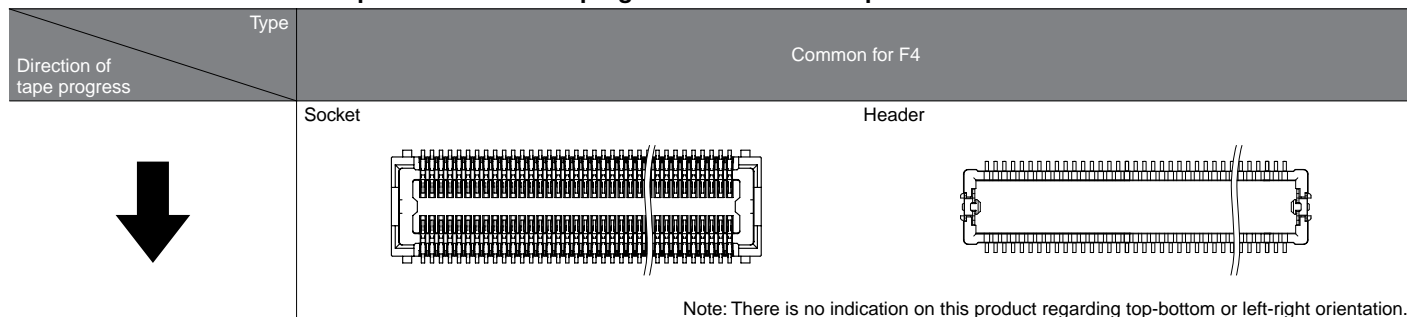

TABLE OF DIMENSIONS

| Mated height | Number of contacts | Type of taping | A | B | C | D | Quantity per reel |
|-------------------------------------|--------------------|----------------|------|------|------|------|-------------------|
| Common for socket and header: 0.9mm | Max. 24 | Tape I | 16.0 | — | 7.5 | 17.4 | 3000 |
| | 26 to 70 | Tape I | 24.0 | — | 11.5 | 25.4 | 3000 |
| | 80 | Tape II | 32.0 | 28.4 | 14.2 | 33.4 | 3000 |

Connector orientation with respect to direction of progress of embossed tape



Note: There is no indication on this product regarding top-bottom or left-right orientation.



Socket



Header

Compliance with RoHS Directive

FEATURES

- 1. 3,000 insertion and removals (when as recommended)**
- 2. Same external dimensions and foot pattern as standard type.**
- 3. Improved mating**

Insertion and removal have become easier due to a reduction in the mating retention force required by the simple locking structure and also in the amount of force needed for insertion and removal. (We cannot warrant anything regarding mating retention.)

APPLICATIONS

Ideal for module unit inspection and equipment assembly inspection

TABLE OF PRODUCT TYPES

☆: Available for sale

| Product name | Number of contacts | | | | | | | | | | | | | | | | | | | | | | |
|-------------------|--------------------|----|----|----|----|----|----|----|----|----|----|----|----|----|----|----|----|----|----|----|----|----|----|
| F4 for inspection | 10 | 12 | 14 | 16 | 20 | 22 | 24 | 26 | 28 | 30 | 32 | 34 | 36 | 38 | 40 | 44 | 48 | 50 | 54 | 60 | 66 | 70 | 80 |
| | ☆ | ☆ | ☆ | ☆ | ☆ | ☆ | ☆ | ☆ | ☆ | ☆ | ☆ | ☆ | ☆ | ☆ | ☆ | ☆ | ☆ | ☆ | ☆ | ☆ | ☆ | ☆ | ☆ |

- Notes: 1. Please inquire about numbers of contacts other than those given above.
 2. Please inquire with us regarding delivery times.
 3. Please keep the minimum unit for ordering no less than 50 pieces per lot.
 4. Please inquire for further information.

PRODUCT TYPES

| Specifications | | Part No. | Specifications | | Part No. |
|----------------|----------------------------|-------------|----------------|----------------------------|--------------|
| Socket | Without positioning bosses | AXK7LE**26G | Header | Without positioning bosses | AXK8LE**26BG |

- Notes: 1. When placing an order, substitute the "*" (asterisk) in the above part number with the number of contacts for the required connector.
 2. The above part numbers are for connectors without positioning bosses, which are standard. When ordering connectors with positioning bosses, please contact our sales office.

NOTES

1. Removal by pulling up from an end causes the entire connector removal force to concentrate on the soldering terminals and end terminals.

Therefore, please lift and remove from the side. Doing so will also prevent cracking of the soldered parts.

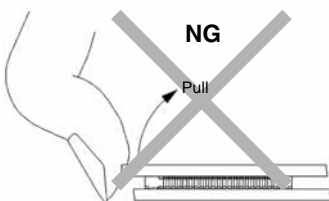
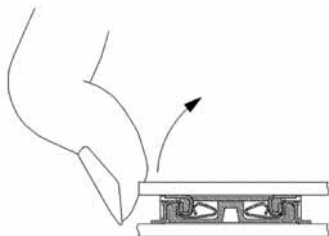

2. PC Boards and Recommended Metal Mask Patterns

Connectors are mounted with high density, with a pitch interval of 0.4 to 0.5 mm.

In order to reduce solder bridge and other issues make sure the proper levels of solder are used.

The figures to the right are recommended metal mask patterns. Please use them as a reference.

In particular, if a lot of solder is used in the header retaining soldering terminals, it might interfere with and cause incomplete socket mating. Therefore, please follow the recommended conditions give on the right.

Socket

Recommended PC board pattern
(Mount pad arrangement pattern)

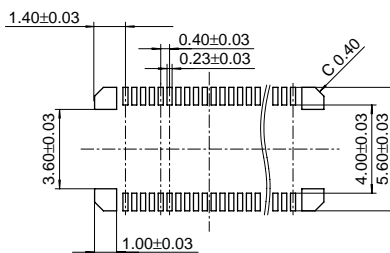

Recommended metal mask pattern

Metal mask thickness: Here, 150 μm
(Terminal portion opening area ratio: 53 %)
(Metal portion opening area ratio: 100 %)

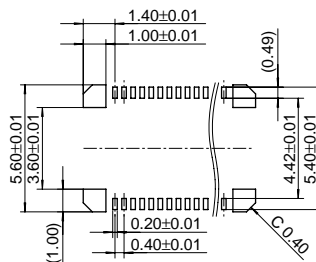

Recommended metal mask pattern

Metal mask thickness: Here, 120 μm
(Terminal portion opening area ratio: 66 %)
(Metal portion opening area ratio: 100 %)

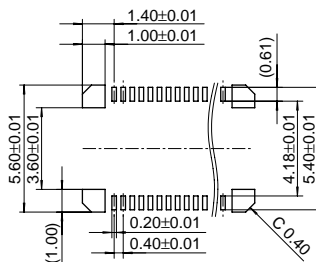

Header

Recommended PC board pattern
(Mount pad arrangement pattern)

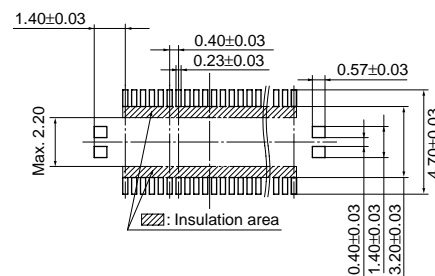

Relation between connector and mounting pad

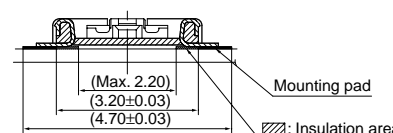

Recommended metal mask pattern

Metal mask thickness: Here, 150 μm
(Terminal portion opening area ratio: 52 %)
(Metal portion opening area ratio: 80 %)

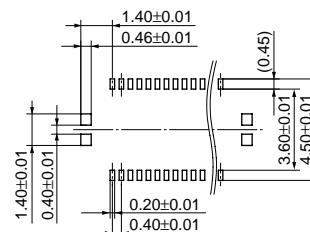

Recommended metal mask pattern

Metal mask thickness: Here, 120 μm
(Terminal portion opening area ratio: 66 %)
(Metal portion opening area ratio: 100 %)

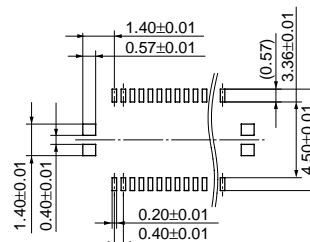

For other details, please verify with the product specification sheets.