

OV3642 3 megapixel product brief



1/4-inch, 3 megapixel CameraChip™ sensor with embedded TrueFocus™ technology

The OV3642 is the most advanced 1/4-inch, 3 megapixel SOC CameraChip sensor on the market today, both in terms of pixel quality as well as the new embedded TrueFocus ISP (image signal processing). Featuring OmniVision's high sensitivity 1.75 micron OmniPixel3-HS™ architecture, the OV3642 achieves a sensitivity of 960mV/(Lux-sec), delivering unparalleled low-light performance, which is crucial for all new high frame rate video applications and taking pictures without a flash.

The embedded TrueFocus ISP (image signal processing) provides all functionality of a complete camera on a single chip, and features extended depth of field (EDoF) capabilities. The unique TrueFocus capabilities can be used with either wave front coded (WFC) lenses as well as standard traditional lenses, generating sharper and clearer images and videos to give the ultimate imaging experience for all camera phone applications.

The OV3642 has an embedded microcontroller to support an internal auto focus engine, a programmable general

purpose I/O for external auto focus control, and an internal anti-shake engine for image stabilization. It uses proprietary sensor technology to improve image quality by reducing or eliminating common lighting and/or electrical sources of image contamination to produce a clean, fully stable, color image. All required image processing functions are programmable through the SCCB interface, MIPI interface or the integrated microcontroller.

The OV3642 image array operates at up to 15 frames per second (fps) in full resolution (QXGA) transferred over a two-lane MIPI interface, or a traditional digital video port (DVP). The sensor contains an integrated JPEG compression engine, simplifying bandwidth limited interfaces. The OV3642's advanced TrueFocus ISP can also be used by an external secondary camera via its DVP while providing continued output through the MIPI interface.

With all its added capabilities, the OV3642 still fits in a standard 8.5 x 8.5mm socket!

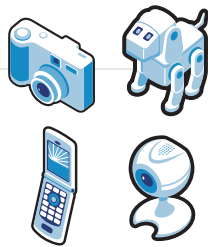

applications

- mobile phones
- toys
- PC multimedia
- digital still cameras

OV3642

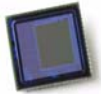

ordering information

- **OV03642-V67A**
(color, lead-free, 67-pin CSP2)
- **OV03642-G00A**
(color, chip probing, no backgrinding)

product features

- extended depth of field with either fixed focus or wavefront coded lenses
- low power usage
- automatic image control functions: automatic exposure control (AEC), automatic white balance (AWB), and automatic 50/60 Hz luminance detection
- support for output formats: RAW RGB, RGB565/555/444, CCIR656, YUV422/420, YCbCr422 and compression (JPEG)
- programmable controls for frame rate, AEC/AGC 16-zone size/position/weight control, mirror and flip, scaling, cropping, windowing, and panning
- embedded one-time programmable (OTP) memory
- integrated anti-shake
- embedded microcontroller
- image quality controls: color saturation, hue, gamma, sharpness (edge enhancement), lens correction, defective pixel canceling and noise canceling
- support for:
 - video or snapshot operations
 - auto focus control (AFC)
 - horizontal/vertical sub-sampling and data compression output
 - LED and flash strobe mode
 - second camera chip-sharing MIPI interface
- output interfaces: MIPI serial, serial SCCB, DVP parallel
- embedded OTP
- built-in 1.5V regulator for core

product specifications

- **array size:** 2048 x 1536
- **power supply:**
 - core: 1.5VDC + 5%
 - analog: 2.6 - 3.0V
 - I/O: 1.7 - 3.0V
- **output format (8-bit):**
 - YUV(422/420)
 - YCbCr422
 - RGB565/555/444
 - 8-bit compression data
 - 8-/10-bit raw RGB data
- **lens size:** 1/4"
- **input clock frequency:** 6 - 27 MHz
- **chief ray angle:** 25° non-linear
- **max image transfer rate:**
 - QXGA (2048 x 1536): 15fps (and any size scaling down from QVGA)
 - XGA (1024 x 768): 30fps (and any size scaling down from XGA)
- **S/N ratio:** 38 dB
- **dynamic range:** 66 dB
- **sensitivity:** 960 mV/(Lux-sec)
- **maximum exposure interval:** 1560 x t_{ROW}
- **pixel size:** 1.75 μm x 1.75 μm
- **image area:** 3626 μm x 2709 μm
- **temperature range:**
 - operating: -20° C to 70° C
 - stable image: 0° C to 50° C
- **package/die dimensions:**
 - CSP2: 6585 μm x 6735 μm
 - COB: 6600 μm x 6750 μm

functional block diagram

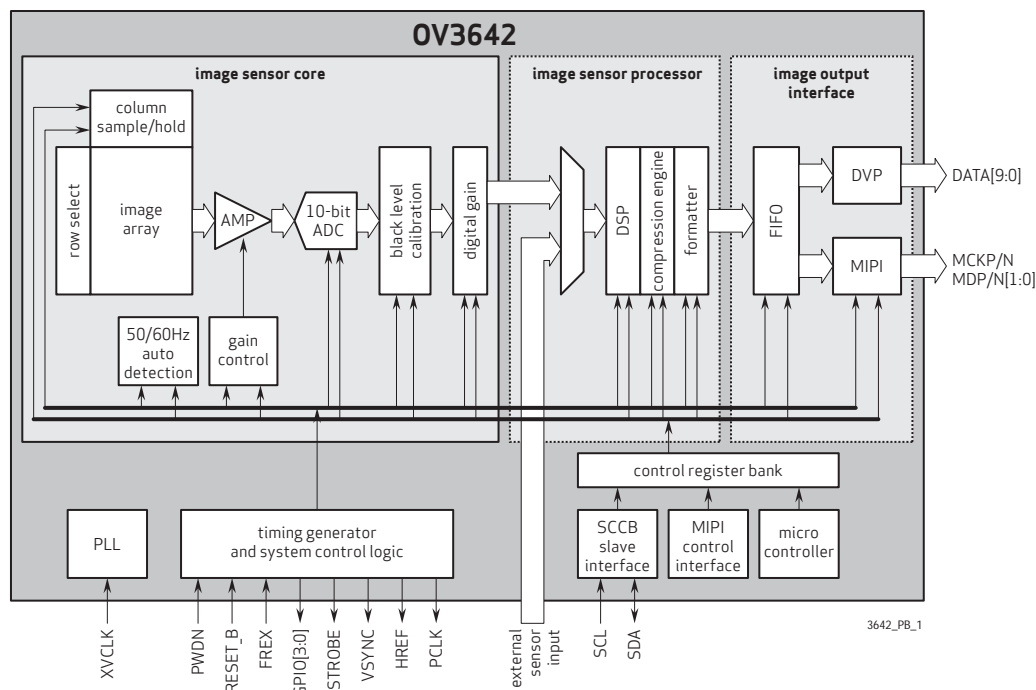

4275 Burton Drive
Santa Clara, CA 95054

tel: +1 408 567 3000
fax: +1 408 567 3001
www.ovt.com

OmniVision reserves the right to make changes to their products or to discontinue any product or service without further notice. OmniVision and OmniPixel are registered trademarks of OmniVision Technologies, Inc. The OmniVision logo, CameraChip and OmniPixel3-HS are trademarks of OmniVision Technologies, Inc. All other trademarks are the property of their respective owners.

