

# DP83816

*DP83816 10/100 Mb/s Integrated PCI Ethernet Media Access Controller and  
Physical Layer (MacPhyter-II)*



Literature Number: SNLS164D

## DP83816 10/100 Mb/s Integrated PCI Ethernet Media Access Controller and Physical Layer (MacPHYTER-II™)

### General Description

DP83816 is a single-chip 10/100 Mb/s Ethernet Controller for the PCI bus. It is targeted at low-cost, high volume PC motherboards, adapter cards, and embedded systems. The DP83816 fully implements the V2.2 33 MHz PCI bus interface for host communications with power management support. Packet descriptors and data are transferred via bus-mastering, reducing the burden on the host CPU. The DP83816 can support full duplex 10/100 Mb/s transmission and reception, with minimum interframe gap.

The DP83816 device is an integration of an enhanced version of the National Semiconductor PCI MAC/BIU (Media Access Controller/Bus Interface Unit) and a 3.3V CMOS physical layer interface.

### Features

- IEEE 802.3 Compliant, PCI V2.2 MAC/BIU supports traditional data rates of 10 Mb/s Ethernet and 100 Mb/s Fast Ethernet (via internal phy)
- Bus master - burst sizes of up to 128 dwords (512 bytes)
- BIU compliant with PC 97 and PC 98 Hardware Design Guides, PC 99 Hardware Design Guide draft, ACPI v1.0, PCI Power Management Specification v1.1, OnNow Device Class Power Management Reference Specification - Network Device Class v1.0a
- Wake on LAN (WOL) support compliant with PC98, PC99, SecureOn, and OnNow, including directed packets, Magic Packet™, VLAN packets, ARP packets, pattern match packets, and Phy status change
- Clkrun function for PCI Mobile Design Guide
- Virtual LAN (VLAN) and long frame support

- Support for IEEE 802.3x Full duplex flow control
- Extremely flexible Rx packet filtration including: single address perfect filter with MSb masking, broadcast, 512 entry multicast/unicast hash table, deep packet pattern matching for up to 4 unique patterns
- Statistics gathered for support of RFC 1213 (MIB II), RFC 1398 (Ether-like MIB), IEEE 802.3 LME, reducing CPU overhead for management
- Internal 2 KB Transmit and 2 KB Receive data FIFOs
- Serial EEPROM port with auto-load of configuration data from EEPROM at power-on
- Flash/PROM interface for remote boot support
- Fully integrated IEEE 802.3/802.3u 3.3V CMOS physical layer
- IEEE 802.3 10BASE-T transceiver with integrated filters
- IEEE 802.3u 100BASE-TX transceiver
- Fully integrated ANSI X3.263 compliant TP-PMD physical sublayer with adaptive equalization and Baseline Wander compensation
- IEEE 802.3u Auto-Negotiation - advertised features configurable via EEPROM
- Full Duplex support for 10 and 100 Mb/s data rates
- Single 25 MHz reference clock
- 144-pin LQFP package
- Low power 3.3V CMOS design with typical consumption of 383 mW operating, 297 mW during WOL and 53 mW during sleep mode
- IEEE 802.3u MII for connecting alternative external Physical Layer Devices
- 3.3V signalling with 5V tolerant I/O.

### System Diagram

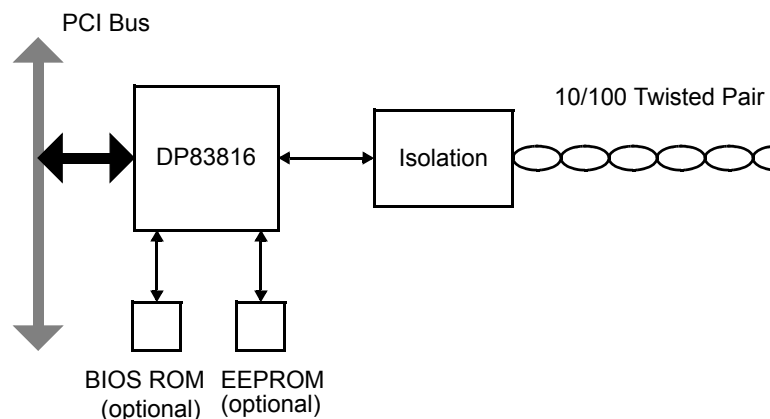

## Table of Contents

<b>1.0 Connection Diagram</b> .....	<b>4</b>	3.12.3 MII Serial Management Access .....	28
1.1 144 LQFP Package (VNG) .....	4	3.12.4 Serial Management Access Protocol .....	28
<b>2.0 Pin Description</b> .....	<b>5</b>	3.12.5 Nibble-wide MII Data Interface .....	28
<b>3.0 Functional Description</b> .....	<b>11</b>	3.12.6 Collision Detection .....	29
3.1 MAC/BIU .....	12	3.12.7 Carrier Sense .....	29
3.1.1 PCI Bus Interface .....	12	<b>4.0 Register Set</b> .....	<b>30</b>
3.1.2 Tx MAC .....	13	4.1 Configuration Registers .....	30
3.1.3 Rx MAC .....	13	4.1.1 Configuration Identification Register .....	30
3.2 Buffer Management .....	13	4.1.2 Configuration Command and Status Register .....	31
3.2.1 Tx Buffer Manager .....	13	4.1.3 Configuration Revision ID Register .....	32
3.2.2 Rx Buffer Manager .....	13	4.1.4 Configuration Latency Timer Register .....	33
3.2.3 Packet Recognition .....	13	4.1.5 Configuration I/O Base Address Register .....	33
3.2.4 MIB .....	14	4.1.6 Configuration Memory Address Register .....	34
3.3 Interface Definitions .....	14	4.1.7 Configuration Subsystem Identification Register .....	34
3.3.1 PCI System Bus .....	14	4.1.8 Boot ROM Configuration Register .....	35
3.3.2 Boot PROM .....	14	4.1.9 Capabilities Pointer Register .....	35
3.3.3 EEPROM .....	14	4.1.10 Configuration Interrupt Select Register .....	36
3.3.4 Clock .....	14	4.1.11 Power Management Capabilities Register .....	36
3.4 Physical Layer .....	16	4.1.12 Power Management Control and Status Register .....	37
3.4.1 Auto-Negotiation .....	16	4.2 Operational Registers .....	38
3.4.2 Auto-Negotiation Register Control .....	16	4.2.1 Command Register .....	39
3.4.3 Auto-Negotiation Parallel Detection .....	16	4.2.2 Configuration and Media Status Register .....	40
3.4.4 Auto-Negotiation Restart .....	17	4.2.3 EEPROM Access Register .....	42
3.4.5 Enabling Auto-Negotiation via Software .....	17	4.2.4 EEPROM Map .....	42
3.4.6 Auto-Negotiation Complete Time .....	17	4.2.5 PCI Test Control Register .....	43
3.5 LED Interfaces .....	17	4.2.6 Interrupt Status Register .....	44
3.6 Half Duplex vs. Full Duplex .....	18	4.2.7 Interrupt Mask Register .....	45
3.7 Phy Loopback .....	18	4.2.8 Interrupt Enable Register .....	47
3.8 Status Information .....	18	4.2.9 Interrupt Holdoff Register .....	47
3.9 100BASE-TX TRANSMITTER .....	18	4.2.10 Transmit Descriptor Pointer Register .....	48
3.9.1 Code-group Encoding and Injection .....	19	4.2.11 Transmit Configuration Register .....	48
3.9.2 Scrambler .....	19	4.2.12 Receive Descriptor Pointer Register .....	50
3.9.3 NRZ to NRZI Encoder .....	20	4.2.13 Receive Configuration Register .....	51
3.9.4 Binary to MLT-3 Convertor / Common Driver .....	20	4.2.14 CLKRUN Control/Status Register .....	52
3.10 100BASE-TX Receiver .....	21	4.2.15 Wake Command/Status Register .....	54
3.10.1 Input and Base Line Wander Compensation .....	21	4.2.16 Pause Control/Status Register .....	56
3.10.2 Signal Detect .....	21	4.2.17 Receive Filter/Match Control Register .....	57
3.10.3 Digital Adaptive Equalization .....	23	4.2.18 Receive Filter/Match Data Register .....	58
3.10.4 Line Quality Monitor .....	24	4.2.19 Receive Filter Logic .....	59
3.10.5 MLT-3 to NRZI Decoder .....	24	4.2.20 Boot ROM Address Register .....	63
3.10.6 Clock Recovery Module .....	25	4.2.21 Boot ROM Data Register .....	63
3.10.7 NRZI to NRZ .....	25	4.2.22 Silicon Revision Register .....	63
3.10.8 Serial to Parallel .....	25	4.2.23 Management Information Base Control Register .....	64
3.10.9 De-scrambler .....	25	4.2.24 Management Information Base Registers .....	65
3.10.10 Code-group Alignment .....	25	4.3 Internal PHY Registers .....	66
3.10.11 4B/5B Decoder .....	25	4.3.1 Basic Mode Control Register .....	66
3.10.12 100BASE-TX Link Integrity Monitor .....	25	4.3.2 Basic Mode Status Register .....	67
3.10.13 Bad SSD Detection .....	25	4.3.3 PHY Identifier Register #1 .....	68
3.11 10BASE-T Transceiver Module .....	26	4.3.4 PHY Identifier Register #2 .....	68
3.11.1 Operational Modes .....	26	4.3.5 Auto-Negotiation Advertisement Register .....	68
3.11.2 Smart Squelch .....	26	4.3.6 Auto-Negotiation Link Partner Ability Register .....	69
3.11.3 Collision Detection .....	26	4.3.7 Auto-Negotiate Expansion Register .....	70
3.11.4 Normal Link Pulse Detection/Generation .....	26	4.3.8 Auto-Negotiation Next Page Transmit Register .....	70
3.11.5 Jabber Function .....	27	4.3.9 PHY Status Register .....	71
3.11.6 Automatic Link Polarity Detection .....	27	4.3.10 MII Interrupt Control Register .....	73
3.11.7 10BASE-T Internal Loopback .....	27	4.3.11 MII Interrupt Status and Misc. Control Register .....	73
3.11.8 Transmit and Receive Filtering .....	27	4.3.12 False Carrier Sense Counter Register .....	74
3.11.9 Transmitter .....	27	4.3.13 Receiver Error Counter Register .....	74
3.11.10 Receiver .....	27	4.3.14 100 Mb/s PCS Configuration and Status Register .....	74
3.11.11 Far End Fault Indication .....	27	4.3.15 PHY Control Register .....	75
3.12 802.3u MII .....	27	4.3.16 10BASE-T Status/Control Register .....	76
3.12.1 MII Access Configuration .....	27	<b>5.0 Buffer Management</b> .....	<b>77</b>
3.12.2 MII Serial Management .....	27	5.1 Overview .....	77
		5.1.1 Descriptor Format .....	77
		5.1.2 Single Descriptor Packets .....	79

5.1.3 Multiple Descriptor Packets	80	6.6 Sleep Mode	89
5.1.4 Descriptor Lists	80	6.6.1 Entering Sleep Mode	89
5.2 Transmit Architecture	81	6.6.2 Exiting Sleep Mode	89
5.2.1 Transmit State Machine	81	6.7 Pin Configuration for Power Management	89
5.2.2 Transmit Data Flow	83	<b>7.0 DC and AC Specifications</b>	<b>90</b>
5.3 Receive Architecture	84	7.1 DC Specifications	90
5.3.1 Receive State Machine	84	7.2 AC Specifications	91
5.3.2 Receive Data Flow	86	7.2.1 PCI Clock Timing	91
<b>6.0 Power Management and Wake-On-LAN</b>	<b>87</b>	7.2.2 X1 Clock Timing	91
6.1 Introduction	87	7.2.3 Power On Reset (PCI Active)	92
6.2 Definitions (for this document only)	87	7.2.4 Non Power On Reset	92
6.3 Packet Filtering	87	7.2.5 POR PCI Inactive	93
6.4 Power Management	87	7.2.6 PCI Bus Cycles	94
6.4.1 D0 State	88	7.2.7 EEPROM Auto-Load	99
6.4.2 D1 State	88	7.2.8 Boot PROM/FLASH	100
6.4.3 D2 State	88	7.2.9 100BASE-TX Transmit	101
6.4.4 D3hot State	88	7.2.10 10BASE-T Transmit End of Packet	102
6.4.5 D3cold State	88	7.2.11 10 Mb/s Jabber Timing	102
6.5 Wake-On-LAN (WOL) Mode	88	7.2.12 10BASE-T Normal Link Pulse	103
6.5.1 Entering WOL Mode	88	7.2.13 Auto-Negotiation Fast Link Pulse (FLP)	103
6.5.2 Wake Events	89	7.2.14 Media Independent Interface (MII)	104
6.5.3 Exiting WOL Mode	89		

### List of Figures

Figure 3-1	DP83816 Functional Block Diagram	11
Figure 3-2	MAC/BIU Functional Block Diagram	12
Figure 3-3	Ethernet Packet Format	14
Figure 3-4	DSP Physical Layer Block Diagram	15
Figure 3-5	LED Loading Example	17
Figure 3-6	100BASE-TX Transmit Block Diagram	19
Figure 3-7	Binary to MLT-3 conversion	20
Figure 3-8	100 M/bs Receive Block Diagram	22
Figure 3-9	100BASE-TX BLW Event Diagram	23
Figure 3-10	EIA/TIA Attenuation vs. Frequency for 0, 50, 100, 130 & 150 meters of CAT V cable	24
Figure 3-11	MLT-3 Signal Measured at All after 0 meters of CAT V cable	24
Figure 3-12	MLT-3 Signal Measured at All after 50 meters of CAT V cable	24
Figure 3-13	MLT-3 Signal Measured at All after 100 meters of CAT V cable	24
Figure 3-14	10BASE-T Twisted Pair Smart Squelch Operation	26
Figure 3-15	Typical MDC/MDIO Read Operation	28
Figure 3-16	Typical MDC/MDIO Write Operation	29
Figure 4-1	Pattern Buffer Memory - 180h words (word = 18bits)	60
Figure 4-2	Hash Table Memory - 40h bytes addressed on word boundaries	62
Figure 5-1	Single Descriptor Packets	79
Figure 5-2	Multiple Descriptor Packets	80
Figure 5-3	List and Ring Descriptor Organization	80
Figure 5-4	Transmit Architecture	81
Figure 5-5	Transmit State Diagram	82
Figure 5-6	Receive Architecture	84
Figure 5-7	Receive State Diagram	86

### List of Tables

Table 3-1	4B5B Code-Group Encoding/Decoding	20
Table 3-2	Typical MDIO Frame Format	28
Table 4-1	Configuration Register Map	30
Table 4-2	Operational Register Map	38
Table 4-3	MIB Registers	65
Table 5-1	DP83816 Descriptor Format	77
Table 5-2	cmds Common Bit Definitions	77
Table 5-3	Transmit Status Bit Definitions	78
Table 5-4	Receive Status Bit Definitions	79
Table 5-5	Transmit State Tables	82
Table 5-6	Receive State Tables	85
Table 6-1	Power Management Modes	87
Table 6-2	PM Pin Configuration	89

# 1.0 Connection Diagram

## 1.1 144 LQFP Package (VNG)

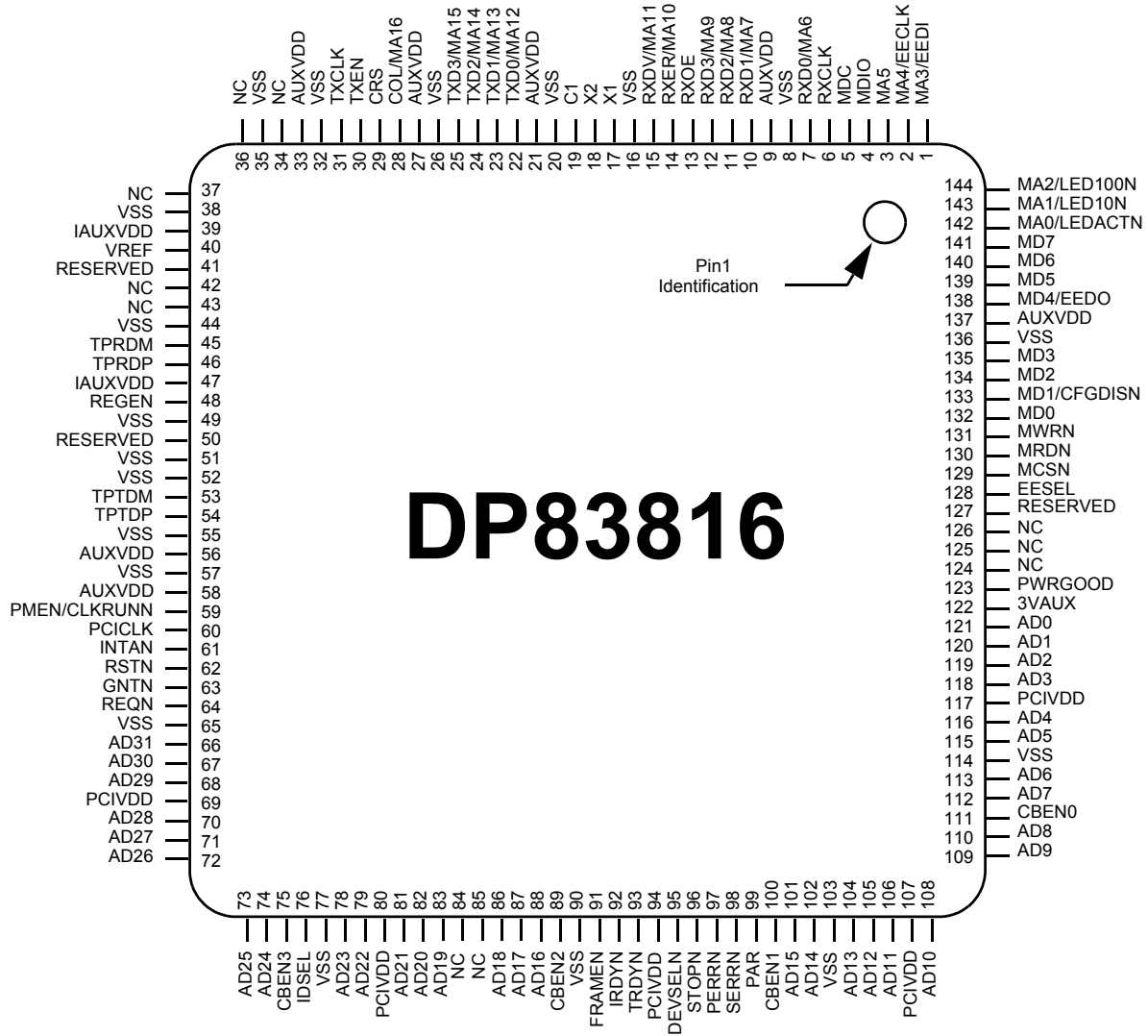

**For Normal Operating Temperature - Order Number DP83816AVNG**

**See NS Package Number VNG144A**

## 2.0 Pin Description

### PCI Bus Interface

Symbol	LQFP Pin No(s)	Dir	Description
AD[31-0]	66, 67, 68, 70, 71, 72, 73, 74, 78, 79, 81, 82, 83, 86, 87, 88, 101, 102, 104, 105, 106, 108, 109, 110, 112, 113, 115, 116, 118, 119, 120, 121	I/O	<b>Address and Data:</b> Multiplexed address and data bus. As a bus master, the DP83816 will drive address during the first bus phase. During subsequent phases, the DP83816 will either read or write data expecting the target to increment its address pointer. As a bus target, the DP83816 will decode each address on the bus and respond if it is the target being addressed.
CBEN[3-0]	75, 89, 100, 111	I/O	<b>Bus Command/Byte Enable:</b> During the address phase these signals define the “bus command” or the type of bus transaction that will take place. During the data phase these pins indicate which byte lanes contain valid data. CBEN[0] applies to byte 0 (bits 7-0) and CBEN[3] applies to byte 3 (bits 31-24) in the Little Endian Mode. In Big Endian Mode, CBEN[3] applies to byte 0 (bits 31-24) and CBEN[0] applies to byte 3 (bits 7-0).
PCICLK	60	I	<b>Clock:</b> This PCI Bus clock provides timing for all bus phases. The rising edge defines the start of each phase. The clock frequency ranges from 0 to 33 MHz.
DEVSELN	95	I/O	<b>Device Select:</b> As a bus master, the DP83816 samples this signal to insure that the destination address for the data transfer is recognized by a PCI target. As a target, the DP83816 asserts this signal low when it recognizes its address after FRAMEN is asserted.
FRAMEN	91	I/O	<b>Frame:</b> As a bus master, this signal is asserted low to indicate the beginning and duration of a bus transaction. Data transfer takes place when this signal is asserted. It is de-asserted before the transaction is in its final phase. As a target, the device monitors this signal before decoding the address to check if the current transaction is addressed to it.
GNTN	63	I	<b>Grant:</b> This signal is asserted low to indicate to the DP83816 that it has been granted ownership of the bus by the central arbiter. This input is used when the DP83816 is acting as a bus master.
IDSEL	76	I	<b>Initialization Device Select:</b> This pin is sampled by the DP83816 to identify when configuration read and write accesses are intended for it.
INTAN	61	O	<b>Interrupt A:</b> This signal is asserted low when an interrupt condition occurs as defined in the Interrupt Status Register, Interrupt Mask, and Interrupt Enable registers.
IRDYN	92	I/O	<b>Initiator Ready:</b> As a bus master, this signal will be asserted low when the DP83816 is ready to complete the current data phase transaction. This signal is used in conjunction with the TRYDN signal. Data transaction takes place at the rising edge of PCICLK when both IRDYN and TRDYN are asserted low. As a target, this signal indicates that the master has put the data on the bus.
PAR	99	I/O	<b>Parity:</b> This signal indicates even parity across AD[31-0] and CBEN[3-0] including the PAR pin. As a master, PAR is asserted during address and write data phases. As a target, PAR is asserted during read data phases.
PERRN	97	I/O	<b>Parity Error:</b> The DP83816 as a master or target will assert this signal low to indicate a parity error on any incoming data (except for special cycles). As a bus master, it will monitor this signal on all write operations (except for special cycles).
REQN	64	O	<b>Request:</b> The DP83816 will assert this signal low to request ownership of the bus from the central arbiter.
RSTN	62	I	<b>Reset:</b> When this signal is asserted all PCI bus outputs of DP83816 will be in TRI-STATE <sup>®</sup> and the device will be put into a known state.

## 2.0 Pin Description (Continued)

### PCI Bus Interface

Symbol	LQFP Pin No(s)	Dir	Description
SERRN	98	I/O	<b>System Error:</b> This signal is asserted low by DP83816 during address parity errors and system errors if enabled.
STOPN	96	I/O	<b>Stop:</b> This signal is asserted low by the target device to request the master device to stop the current transaction.
TRDYN	93	I/O	<b>Target Ready:</b> As a master, this signal indicates that the target is ready for the data during write operation and with the data during read operation. As a target, this signal will be asserted low when the (target) device is ready to complete the current data phase transaction. This signal is used in conjunction with the IRDYN signal. Data transaction takes place at the rising edge of PCICLK when both IRDYN and TRDYN are asserted low.
PMEN/ CLKRUNN	59	I/O	<b>Power Management Event/Clock Run Function:</b> This pin is a dual function pin. The function of this pin is determined by the CLKRUN_EN bit 0 of the CLKRUN Control and Status register (CCSR). Default operation of this pin is PMEN. <b>Power Management Event:</b> This signal is asserted low by the DP83816 to indicate that a power management event has occurred. For pin connection please refer to Section 6.7. <b>Clock Run Function:</b> In this mode, this pin is used to indicate when the PCICLK will be stopped.
3VAUX	122	I	<b>PCI Auxiliary Voltage Sense:</b> This pin is used to sense the presence of a 3.3V auxiliary supply in order to define the PME Support available. For pin connection please refer to Section 6.7.  This pin has an internal weak pull down.
PWRGOOD	123	I	<b>PCI bus power good:</b> Connected to PCI bus 3.3V power, this pin is used to sense the presence of PCI bus power during the D3 power management state.  This pin has an internal weak pull down.

## 2.0 Pin Description (Continued)

### Media Independent Interface (MII)

Symbol	LQFP Pin No(s)	Dir	Description
COL	28	I	<b>Collision Detect:</b> The COL signal is asserted high asynchronously by the external PMD upon detection of a collision on the medium. It will remain asserted as long as the collision condition persists.
CRS	29	I	<b>Carrier Sense:</b> This signal is asserted high asynchronously by the external PMD upon detection of a non-idle medium.
MDC	5	O	<b>Management Data Clock:</b> Clock signal with a maximum rate of 2.5 MHz used to transfer management data for the external PMD on the MDIO pin.
MDIO	4	I/O	<b>Management Data I/O:</b> Bidirectional signal used to transfer management information for the external PMD. (See Section 3.12.4 for details on connections when MII is used.)
RXCLK	6	I	<b>Receive Clock:</b> A continuous clock, sourced by an external PMD device, that is recovered from the incoming data. During 100 Mb/s operation RXCLK is 25 MHz and during 10 Mb/s this is 2.5 MHz.
RXD3/MA9, RXD2/MA8, RXD1/MA7, RXD0/MA6	12, 11, 10, 7	I   O	<b>Receive Data:</b> Sourced from an external PMD, that contains data aligned on nibble boundaries and are driven synchronous to RXCLK. RXD[3] is the most significant bit and RXD[0] is the least significant bit. <b>BIOS ROM Address:</b> During external BIOS ROM access, these signals become part of the ROM address.
RXDV/MA11	15	I   O	<b>Receive Data Valid:</b> Indicates that the external PMD is presenting recovered and decoded nibbles on the RXD signals, and that RXCLK is synchronous to the recovered data in 100 Mb/s operation. This signal will encompass the frame, starting with the Start-of-Frame delimiter (JK) and excluding any End-of-Frame delimiter (TR). <b>BIOS ROM Address:</b> During external BIOS ROM access, this signal becomes part of the ROM address.
RXER/MA10	14	I   O	<b>Receive Error:</b> Asserted high synchronously by the external PMD whenever it detects a media error and RXDV is asserted in 100 Mb/s operation. <b>BIOS ROM Address:</b> During external BIOS ROM access, this signal becomes part of the ROM address.
RXOE	13	O	<b>Receive Output Enable:</b> Used to disable an external PMD while the BIOS ROM is being accessed.
TXCLK	31	I	<b>Transmit Clock:</b> A continuous clock that is sourced by the external PMD. During 100 Mb/s operation this is 25 MHz +/- 100 ppm. During 10 Mb/s operation this clock is 2.5 MHz +/- 100 ppm.
TXD3/MA15, TXD2/MA14, TXD1/MA13, TXD0/MA12	25, 24, 23, 22	O   O	<b>Transmit Data:</b> Signals which are driven synchronous to the TXCLK for transmission to the external PMD. TXD[3] is the most significant bit and TXD[0] is the least significant bit. <b>BIOS ROM Address:</b> During external BIOS ROM access, these signals become part of the ROM address.
TXEN	30	O	<b>Transmit Enable:</b> This signal is synchronous to TXCLK and provides precise framing for data carried on TXD[3-0] for the external PMD. It is asserted when TXD[3-0] contains valid data to be transmitted.

Note: MII is normally in TRI-STATE, unless enabled by CFG:EXT\_PHY. See Section 4.2.2.



## 2.0 Pin Description (Continued)

### 100BASE-TX/10BASE-T Interface

Symbol	LQFP Pin No(s)	Dir	Description
TPTDP, TPTDM	54, 53	A-O	<p><b>Transmit Data:</b> Differential common output driver. This differential common output is configurable to either 10BASE-T or 100BASE-TX signaling:</p> <p>10BASE-T: Transmission of Manchester encoded 10BASE-T packet data as well as Link Pulses (including Fast Link Pulses for Auto-Negotiation purposes).</p> <p>100BASE-TX: Transmission of ANSI X3T12 compliant MLT-3 data.</p> <p>The DP83816 will automatically configure this common output driver for the proper signal type as a result of either forced configuration or Auto-Negotiation.</p>
TPRDP, TPRDM	46, 45	A-I	<p><b>Receive Data:</b> Differential common input buffer. This differential common input can be configured to accept either 100BASE-TX or 10BASE-T signaling:</p> <p>10BASE-T: Reception of Manchester encoded 10BASE-T packet data as well as normal Link Pulses and Fast Link Pulses for Auto-Negotiation purposes.</p> <p>100BASE-TX: Reception of ANSI X3T12 compliant scrambled MLT-3 data.</p> <p>The DP83816 will automatically configure this common input buffer to accept the proper signal type as a result of either forced configuration or Auto-Negotiation.</p>

### BIOS ROM/Flash Interface

Symbol	LQFP Pin No(s)	Dir	Description
MCSN	129	O	<p><b>BIOS ROM/Flash Chip Select:</b> During a BIOS ROM/Flash access, this signal is used to select the ROM device.</p>
MD7, MD6, MD5, MD4/EEDO, MD3, MD2, MD1/CFGDISN, MD0	141, 140, 139, 138, 135, 134, 133, 132	I/O	<p><b>BIOS ROM/Flash Data Bus:</b> During a BIOS ROM/Flash access these signals are used to transfer data to or from the ROM/Flash device.</p> <p>MD[5:0] pins have internal weak pull ups.</p> <p>MD6 and MD7 pins have internal weak pull downs.</p>
MA5, MA4/EECLK, MA3/EEDI, MA2/LED100LNK, MA1/LED10LNK, MA0/LEDACT	3, 2, 1, 144, 143, 142	O	<p><b>BIOS ROM/Flash Address:</b> During a BIOS ROM/Flash access, these signals are used to drive the ROM/Flash address.</p>
MWRN	131	O	<p><b>BIOS ROM/Flash Write:</b> During a BIOS ROM/Flash access, this signal is used to enable data to be written to the Flash device.</p>
MRDN	130	O	<p><b>BIOS ROM/Flash Read:</b> During a BIOS ROM/Flash access, this signal is used to enable data to be read from the Flash device.</p>

Note: DP83816 supports NM27LV010 for the BIOS ROM interface device.

## 2.0 Pin Description (Continued)

### Clock Interface

Symbol	LQFP Pin No(s)	Dir	Description
X1	17	I	<b>Crystal/Oscillator Input:</b> This pin is the primary clock reference input for the DP83816 and must be connected to a 25 MHz 0.005% (50ppm) clock source. The DP83816 device supports either an external crystal resonator connected across pins X1 and X2, or an external CMOS-level oscillator source connected to pin X1 only.
X2	18	O	<b>Crystal Output:</b> This pin is used in conjunction with the X1 pin to connect to an external 25 MHz crystal resonator device. This pin must be left unconnected if an external CMOS oscillator clock source is utilized. For more information see the definition for pin X1.

### LED Interface

Symbol	LQFP Pin No(s)	Dir	Description
LEDACTN/MA0	142	O	<b>TX/RX Activity:</b> This pin is an output indicating transmit/receive activity. This pin is driven low to indicate active transmission or reception, and can be used to drive a low current LED (<6 mA). The activity event is stretched to a minimum duration of approximately 50 ms.
LED100N/MA2	144	O	<b>100 Mb/s Link:</b> This pin is an output indicating the 100 Mb/s Link status. This pin is driven low to indicate Good Link status for 100 Mb/s operation, and can be used to drive a low current LED (<6 mA).
LED10N/MA1	143	O	<b>10 Mb/s Link:</b> This pin is an output indicating the 10 Mb/s Link status. This pin is driven low to indicate Good Link status for 10 Mb/s operation, and can be used to drive a low current LED (<6 mA).

### Serial EEPROM Interface

Symbol	LQFP Pin No(s)	Dir	Description
EESEL	128	O	<b>EEPROM Chip Select:</b> This signal is used to enable an external EEPROM device.
EECLK/MA4	2	O	<b>EEPROM Clock:</b> During an EEPROM access (EESEL asserted), this pin is an output used to drive the serial clock to an external EEPROM device.
EEDI/MA3	1	O	<b>EEPROM Data In:</b> During an EEPROM access (EESEL asserted), this pin is an output used to drive opcode, address, and data to an external serial EEPROM device.
EEDO/MD4	138	I	<b>EEPROM Data Out:</b> During an EEPROM access (EESEL asserted), this pin is an input used to retrieve EEPROM serial read data. This pin has an internal weak pull up.
MD1/CFGDISN	133	I/O	<b>Configuration Disable:</b> When pulled low at power-on time, disables load of configuration data from the EEPROM. Use 1 K $\Omega$ to ground to disable configuration load.

Note: DP83816 supports NMC93C46 for the EEPROM device.

## 2.0 Pin Description (Continued)

### External Reference Interface

Symbol	LQFP Pin No(s)	Dir	Description
VREF	40	I	<b>Bandgap Reference:</b> External current reference resistor for internal Phy bandgap circuitry. The value of this resistor is 10K $\Omega$ 1% metal film (100 ppm/ $^{\circ}$ C) which must be connected from the VREF pin to analog ground.

### No Connects and Reserved

Symbol	LQFP Pin No(s)	Dir	Description
NC	34, 42, 43, 36, 37, 84, 85, 124, 125, 126		No Connect
RESERVED	41, 50, 127		These pins are reserved and cannot be connected to any external logic or net.
REGEN	48		Reserved and cannot be connected to any external logic or net.. This pin has an internal weak pull down.

### Supply Pins

Symbol	LQFP Pin No(s)	Dir	Description
C1	19	S	Connect to GND through 10uF and 0.1uF external capacitors in parallel.
IAUXVDD	39, 47	S	Connect to isolated Aux 3.3V supply VDD
AUXVDD	9, 21, 27, 33, 56, 58, 137	S	Connect to Aux 3.3V supply VDD
PCIVDD	69, 80, 94, 107, 117	S	PCI VDD - connect to PCI bus 3.3V VDD
VSS	8, 16, 20, 26, 32, 35, 38, 44, 49, 51, 52, 55, 57, 65, 77, 90, 103, 114, 136	S	VSS

### 3.0 Functional Description

DP83816 consists of a MAC/BIU (Media Access Controller/Bus Interface Unit), a physical layer interface, SRAM, and miscellaneous support logic. The MAC/BIU includes the PCI bus, BIOS ROM and EEPROM interfaces,

and an 802.3 MAC. The physical layer interface used is a single-port version of the 3.3V DsPhyterII. Internal memory consists of one - 0.5 KB and two - 2 KB SRAM blocks.

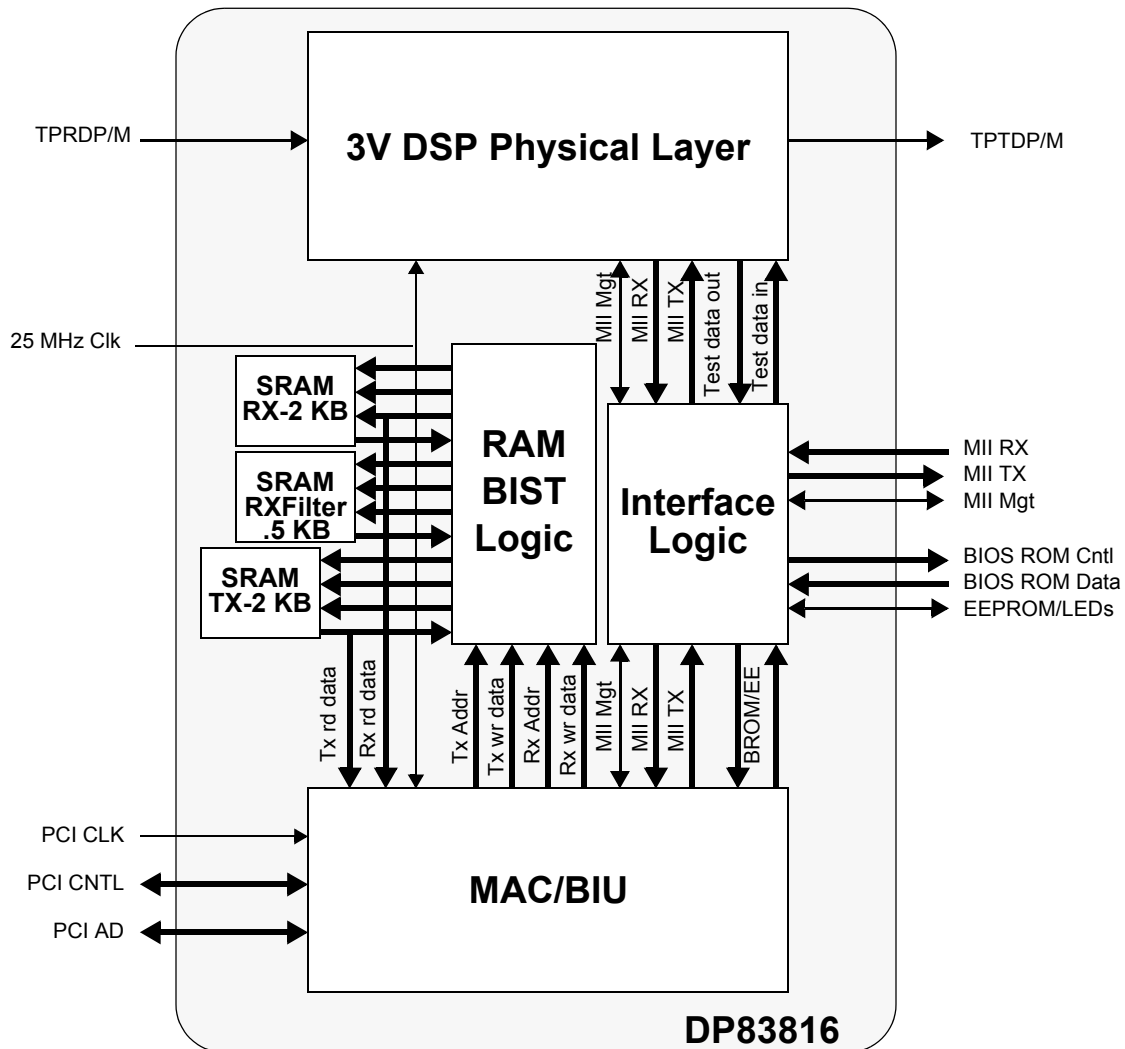

Figure 3-1 DP83816 Functional Block Diagram

3.0 Functional Description (Continued)

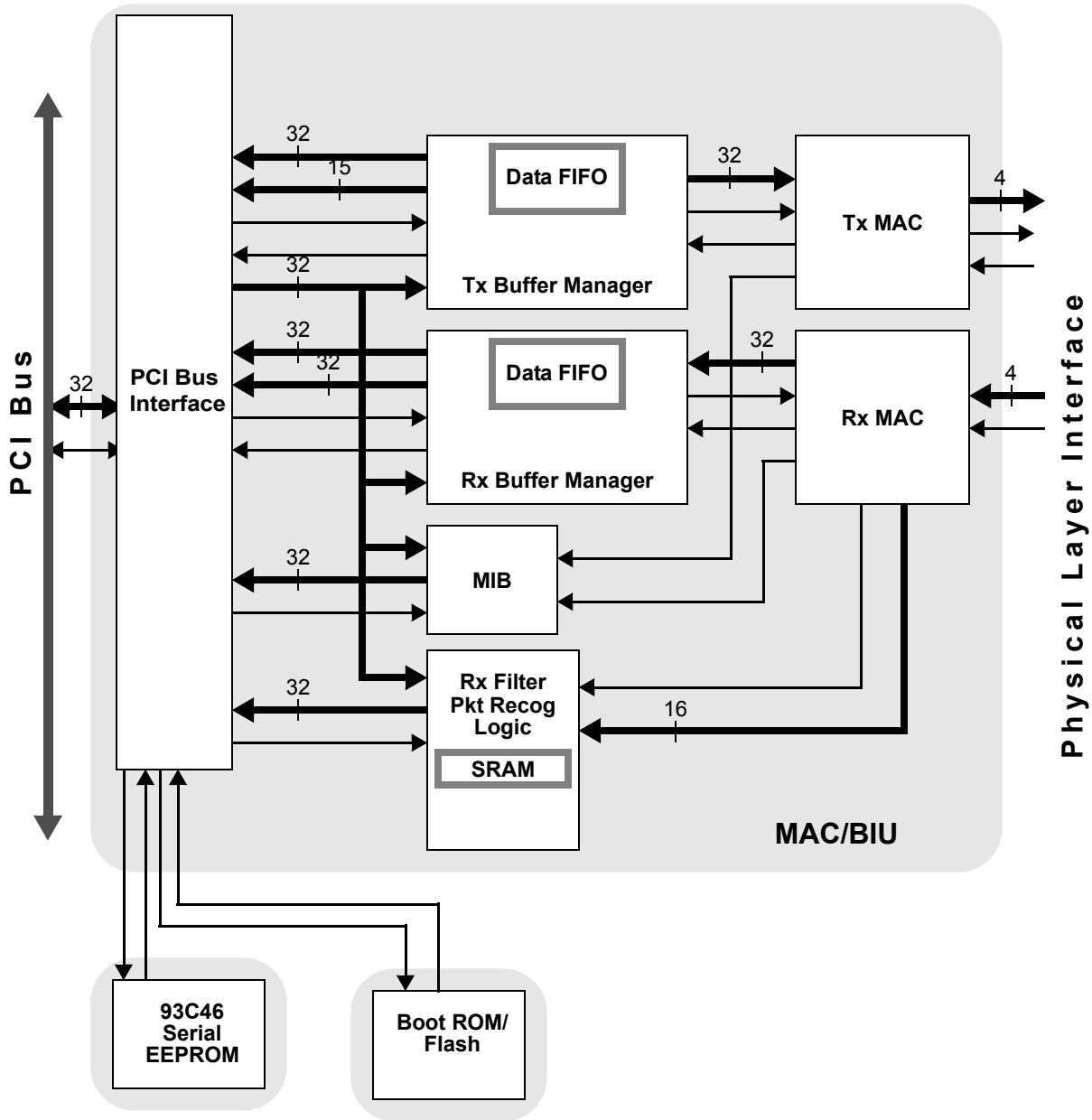

Figure 3-2 MAC/BIU Functional Block Diagram

3.1 MAC/BIU

The MAC/BIU is a derivative design from the DP83810 (Euphrates). The original MAC/BIU design has been optimized to improve logic efficiency and enhanced to add features consistent with current market needs and specification compliance. The MAC/BIU design blocks are discussed in this section.

3.1.1 PCI Bus Interface

This block implements PCI v2.2 bus protocols, and configuration space. Supports bus master reads and writes to CPU memory, and CPU access to on-chip register space. Additional functions provided include: configuration

control, serial EEPROM access with auto configuration load, interrupt control, power management control with support for PME or CLKRUN function.

3.1.1.1 Byte Ordering

The DP83816 can be configured to order the bytes of data on the AD[31:0] bus to conform to little endian or big endian ordering through the use of the Configuration Register, bit 0 (CFG:BEM). By default, the device is in little endian ordering. Byte ordering only affects data FIFOs. Register information remains bit aligned (i.e. AD[31] maps to bit 31 in any register space, AD[0] maps to bit 0, etc.).

### 3.0 Functional Description (Continued)

**Little Endian (CFG:BEM=0):** The byte orientation for receive and transmit data in system memory is as follows:

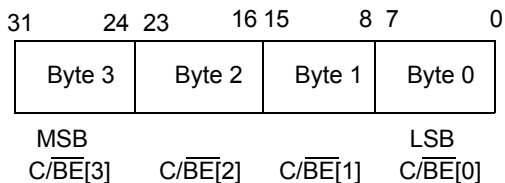

**Big Endian (CFG:BEM=1):** The byte orientation for receive and transmit data in system memory is as follows:

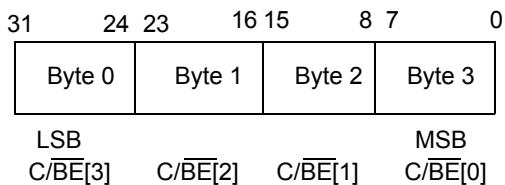

#### 3.1.1.2 PCI Bus Interrupt Control

PCI bus interrupts for the DP83816 are asynchronously performed by asserting pin INTAN. This pin is an open drain output. The source of the interrupt can be determined by reading the Interrupt Status Register (ISR). One or more bits in the ISR will be set, denoting all currently pending interrupts. **Caution:** Reading of the ISR clears ALL bits. Masking of specified interrupts can be accomplished by using the Interrupt Mask Register (IMR).

#### 3.1.1.3 Timer

The Latency Timer described in CFGLAT:LAT defines the minimum number of bus clocks that the device will hold the bus. Once the device gains control of the bus and issues FRAMEN, the Latency Timer will begin counting down. If GNTN is de-asserted before the DP83816 has finished with the bus, the device will maintain ownership of the bus until the timer reaches zero (or has finished the bus transfer). The timer is an 8-bit counter.

#### 3.1.2 Tx MAC

This block implements the transmit portion of 802.3 Media Access Control. The Tx MAC retrieves packet data from the Tx Buffer Manager and sends it out through the transmit portion. Additionally, the Tx MAC provides MIB control information for transmit packets.

#### 3.1.3 Rx MAC

This block implements the receive portion of 802.3 Media Access Control. The Rx MAC retrieves packet data from the receive portion and sends it to the Rx Buffer Manager. Additionally, the Rx MAC provides MIB control information and packet address data for the Rx Filter.

### 3.2 Buffer Management

The buffer management scheme used on the DP83816 allows quick, simple and efficient use of the frame buffer memory. Frames are saved in similar formats for both

transmit and receive. The buffer management scheme also uses separate buffers and descriptors for packet information. This allows effective transfers of data from the receive buffer to the transmit buffer by simply transferring the descriptor from the receive queue to the transmit queue.

The format of the descriptors allows the packets to be saved in a number of configurations. A packet can be stored in memory with a single descriptor per single packet, or multiple descriptors per single packet. This flexibility allows the user to configure the DP83816 to maximize efficiency. Architecture of the specific system's buffer memory, as well as the nature of network traffic, will determine the most suitable configuration of packet descriptors and fragments. Refer to the Buffer Management Section (Section 5.0) for more information.

#### 3.2.1 Tx Buffer Manager

This block DMA's packet data from PCI memory space and places it in the 2 KB transmit FIFO, and pulls data from the FIFO to send to the Tx MAC. Multiple packets (4) may be present in the FIFO, allowing packets to be transmitted with minimum interframe gap. The way in which the FIFO is emptied and filled is controlled by the FIFO threshold values in the TXCFG register: FLTH (Tx Fill Threshold) and DRTN (Tx Drain Threshold). These values determine how full or empty the FIFO must be before the device requests the bus. Additionally, once the DP83816 requests the bus, it will attempt to empty or fill the FIFO as allowed by the MXDMA setting in the TXCFG register.

#### 3.2.2 Rx Buffer Manager

This block retrieves packet data from the Rx MAC and places it in the 2 KB receive data FIFO, and pulls data from the FIFO for DMA to PCI memory space. The Rx Buffer Manager maintains a status FIFO, allowing up to 4 packets to reside in the FIFO at once. Similar to the transmit FIFO, the receive FIFO is controlled by the FIFO threshold value in the RXCFG register: DRTH (Rx Drain Threshold). This value determines the number of long words written into the FIFO from the MAC unit before a DMA request for system memory access occurs. Once the DP83816 gets the bus, it will continue to transfer the long words from the FIFO until the data in the FIFO is less than one long word, or has reached the end of the packet, or the max DMA burst size is reached (RXCFG:MXDMA).

#### 3.2.3 Packet Recognition

The Receive packet filter and recognition logic allows software to control which packets are accepted based on destination address and packet type. Address recognition logic includes support for broadcast, multicast hash, and unicast addresses. The packet recognition logic includes support for WOL, Pause, and programmable pattern recognition.

The standard 802.3 Ethernet packet consists of the following fields: Preamble (PA), Start of Frame Delimiter (SFD), Destination Address (DA), Source Address (SA), Length (LEN), Data and Frame Check Sequence (FCS). All fields are fixed length except for the data field. During reception, the PA, SFD and FCS are stripped. During transmission, the DP83816 generates and appends the PA, SFD and FCS.

### 3.0 Functional Description (Continued)

PA	SFD	DA	SA	LEN	Data	FCS
60b	4b	6B	6B	2B	46B-1500B	4B

Note: B = Bytes  
b = bits

**Figure 3-3 Ethernet Packet Format**

#### 3.2.4 MIB

The MIB block contains counters to track certain media events required by the management specifications RFC 1213 (MIB II), RFC 1398 (Ether-like MIB), and IEEE 802.3 LME. The counters provided are for events which are either difficult or impossible to be intercepted directly by software. Not all counters are implemented, however required counters can be calculated from the counters provided.

### 3.3 Interface Definitions

#### 3.3.1 PCI System Bus

This interface allows direct connection of the DP83816 to a 33 MHz PCI system bus. The DP83816 supports zero wait state data transfers with burst sizes up to 128 dwords. The

DP83816 conforms to 3.3V AC/DC specifications, but has 5V tolerant inputs.

#### 3.3.2 Boot PROM

The BIOS ROM interface allows the DP83816 to read from and write data to an external ROM/Flash device.

#### 3.3.3 EEPROM

The DP83816 supports the attachment of an external EEPROM. The EEPROM interface provides the ability for the DP83816 to read from and write data to an external serial EEPROM device. The DP83816 will auto-load values from the EEPROM to certain fields in PCI configuration space and operational space and perform a checksum to verify that the data is valid. Values in the external EEPROM allow default fields in PCI configuration space and I/O space to be overridden following a hardware reset. If the EEPROM is not present, the DP83816 initialization uses default values for the appropriate Configuration and Operational Registers. Software can read and write to the EEPROM using "bit-bang" accesses via the EEPROM Access Register (MEAR).

#### 3.3.4 Clock

The clock interface provides the 25 MHz clock reference input for the DP83816 IC. The X1 input signal amplitude should be approximately 1V. This interface supports operation from a 25 MHz, 50 ppm CMOS oscillator, or a 25 MHz, 50 ppm, parallel, 20 pF load, < 40  $\Omega$  ESR crystal resonator. A 20pF crystal resonator would require C1 and

### 3.0 Functional Description (Continued)

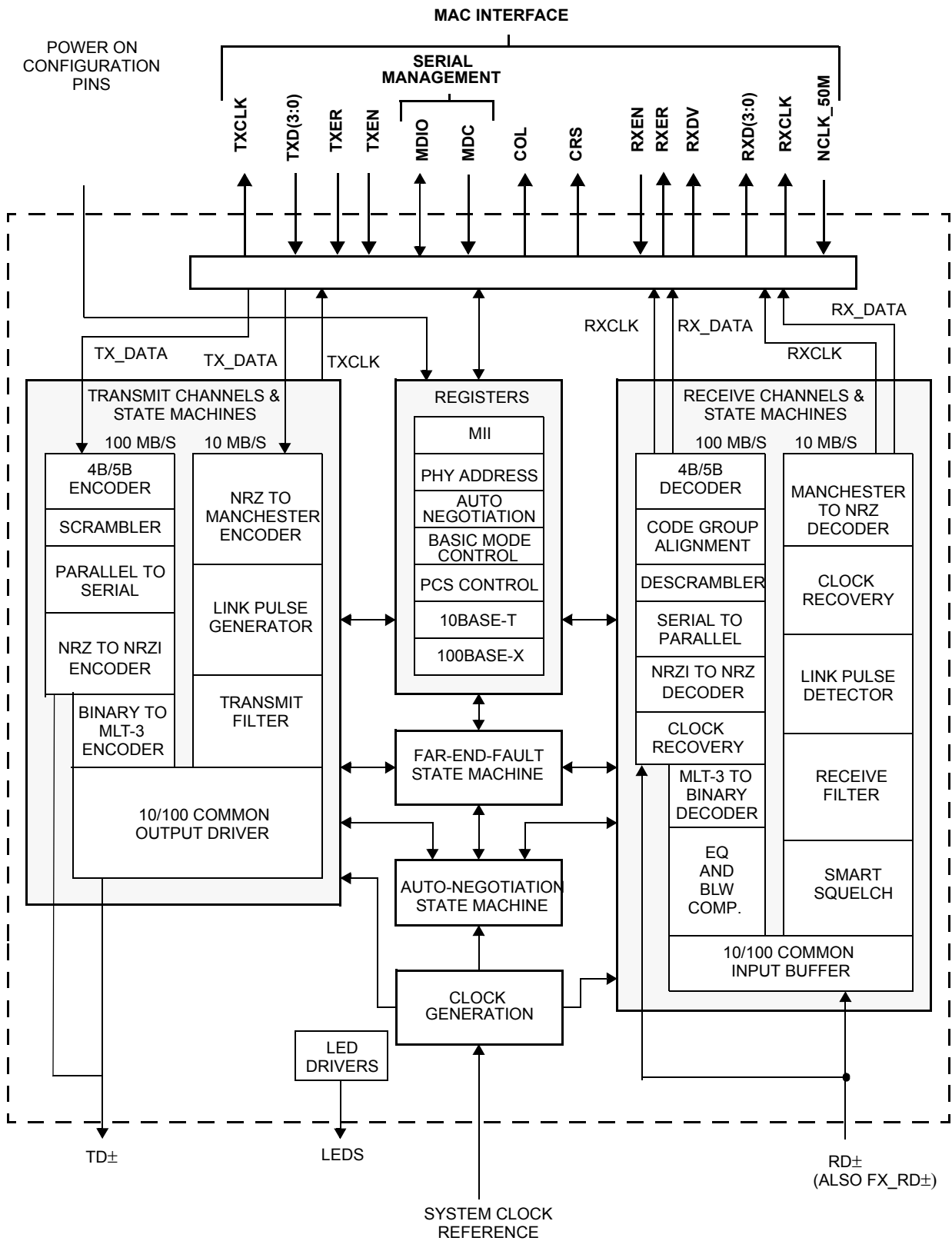

Figure 3-4 DSP Physical Layer Block Diagram



## 3.0 Functional Description (Continued)

### 3.4 Physical Layer

The DP83816 has a full featured physical layer device with integrated PMD sub-layers to support both 10BASE-T and 100BASE-TX Ethernet protocols. The physical layer is designed for easy implementation of 10/100 Mb/s Ethernet home or office solutions. It interfaces directly to twisted pair media via an external transformer. The physical layer utilizes on chip Digital Signal Processing (DSP) technology and digital PLLs for robust performance under all operating conditions, enhanced noise immunity, and lower external component count when compared to analog solutions.

#### 3.4.1 Auto-Negotiation

The Auto-Negotiation function provides a mechanism for exchanging configuration information between two ends of a link segment and automatically selecting the highest performance mode of operation supported by both devices. Fast Link Pulse (FLP) Bursts provide the signalling used to communicate Auto-Negotiation abilities between two devices at each end of a link segment. For further detail regarding Auto-Negotiation, refer to Clause 28 of the IEEE 802.3u specification. The DP83816 supports four different Ethernet protocols (10 Mb/s Half Duplex, 10 Mb/s Full Duplex, 100 Mb/s Half Duplex, and 100 Mb/s Full Duplex), so the inclusion of Auto-Negotiation ensures that the highest performance protocol will be selected based on the advertised ability of the Link Partner. The Auto-Negotiation function within the DP83816 is controlled by internal register access. Auto-Negotiation will be set at power-up/reset, and also when a link status (up/valid) change occurs.

#### 3.4.2 Auto-Negotiation Register Control

When Auto-Negotiation is enabled, the DP83816 transmits the abilities programmed into the Auto-Negotiation Advertisement register (ANAR) via FLP Bursts. Any combination of 10 Mb/s, 100 Mb/s, Half-Duplex, and Full Duplex modes may be selected. The default setting of bits [8:5] in the ANAR and bit 12 in the BMCR register are determined at power-up.

The BMCR provides software with a mechanism to control the operation of the DP83816. Bits 1 & 2 of the PHYSTS register are only valid if Auto-Negotiation is disabled or after Auto-Negotiation is complete. The Auto-Negotiation protocol compares the contents of the ANLPAR and ANAR registers and uses the results to automatically configure to the highest performance protocol common to the local and far-end port. The results of Auto-Negotiation may be accessed in register C0h (PHYSTS), bit 4: Auto-Negotiation Complete, bit 2: Duplex Status and bit 1: Speed Status.

Auto-Negotiation Priority Resolution:

- (1) 100BASE-TX Full Duplex (Highest Priority)
- (2) 100BASE-TX Half Duplex
- (3) 10BASE-T Full Duplex
- (4) 10BASE-T Half Duplex (Lowest Priority)

The Basic Mode Control Register (BMCR) provides control for enabling, disabling, and restarting the Auto-Negotiation process. When Auto-Negotiation is disabled the Speed Selection bit in the BMCR (bit 13) controls switching between 10 Mb/s or 100 Mb/s operation, and the Duplex Mode bit (bit 8) controls switching between full duplex operation and half duplex operation. The Speed Selection and Duplex Mode bits have no effect on the mode of

operation when the Auto-Negotiation Enable bit (bit 12) is set.

The Basic Mode Status Register (BMSR) indicates the set of available abilities for technology types, Auto-Negotiation ability, and Extended Register Capability. These bits are permanently set to indicate the full functionality of the DP83816 (only the 100BASE-T4 bit is not set since the DP83816 does not support that function).

The BMSR also provides status on:

- Auto-Negotiation complete (bit 5)
- Link Partner advertising that a remote fault has occurred (bit 4)
- Valid link has been established (bit 2)
- Support for Management Frame Preamble suppression (bit 6)

The Auto-Negotiation Advertisement Register (ANAR) indicates the Auto-Negotiation abilities to be advertised by the DP83816. All available abilities are transmitted by default, but any ability can be suppressed by writing to the ANAR. Updating the ANAR to suppress an ability is one way for a management agent to change (force) the technology that is used.

The Auto-Negotiation Link Partner Ability Register (ANLPAR) is used to receive the base link code word as well as all next page code words during the negotiation. Furthermore, the ANLPAR will be updated to either 0081h or 0021h for parallel detection to either 100 Mb/s or 10 Mb/s respectively.

The Auto-Negotiation Expansion Register (ANER) indicates additional Auto-Negotiation status. The ANER provides status on:

- Parallel Detect Fault occurrence (bit 4)
- Link Partner support of the Next Page function (bit 3)
- DP83816 support of the Next Page function (bit 2). The DP83816 supports the Next Page function.
- Current page being exchanged by Auto-Negotiation has been received (bit 1)
- Link Partner support of Auto-Negotiation (bit 0)

#### 3.4.3 Auto-Negotiation Parallel Detection

The DP83816 supports the Parallel Detection function as defined in the IEEE 802.3u specification. Parallel Detection requires both the 10 Mb/s and 100 Mb/s receivers to monitor the receive signal and report link status to the Auto-Negotiation function. Auto-Negotiation uses this information to configure the correct technology in the event that the Link Partner does not support Auto-Negotiation yet is transmitting link signals that the 100BASE-TX or 10BASE-T PMAs (Physical Medium Attachments) recognize as valid link signals.

If the DP83816 completes Auto-Negotiation as a result of Parallel Detection, bits 5 and 7 within the ANLPAR register will be updated to reflect the mode of operation present in the Link Partner. Note that bits 4:0 of the ANLPAR will also be set to 00001 based on a successful parallel detection to indicate a valid 802.3 selector field. Software may determine that negotiation completed via Parallel Detection by reading the ANER (98h) register with bit 0, Link Partner Auto-Negotiation Able bit, being reset to a zero, once the Auto-Negotiation Complete bit, bit 5 of the BMSR (84h) register is set to a one. If configured for parallel detect

### 3.0 Functional Description (Continued)

mode, and any condition other than a single good link occurs, then the parallel detect fault bit will set to a one, bit 4 of the ANER register (98h).

#### 3.4.4 Auto-Negotiation Restart

Once Auto-Negotiation has completed, it may be restarted at any time by setting bit 9 (Restart Auto-Negotiation) of the BMCR to one. If the mode configured by a successful Auto-Negotiation loses a valid link, then the Auto-Negotiation process will resume and attempt to determine the configuration for the link. This function ensures that a valid configuration is maintained if the cable becomes disconnected.

A renegotiation request from any entity, such as a management agent, will cause the DP83816 to halt any transmit data and link pulse activity until the break\_link\_timer expires (~1500 ms). Consequently, the Link Partner will go into link fail and normal Auto-Negotiation resumes. The DP83816 will resume Auto-Negotiation after the break\_link\_timer has expired by issuing FLP (Fast Link Pulse) bursts.

#### 3.4.5 Enabling Auto-Negotiation via Software

It is important to note that if the DP83816 has been initialized upon power-up as a non-auto-negotiating device (forced technology), and it is then required that Auto-Negotiation or re-Auto-Negotiation be initiated via software, bit 12 (Auto-Negotiation Enable) of the Basic Mode Control Register must first be cleared and then set for any Auto-Negotiation function to take effect.

#### 3.4.6 Auto-Negotiation Complete Time

Parallel detection and Auto-Negotiation take approximately 2-3 seconds to complete. In addition, Auto-Negotiation with next page should take approximately 2-3 seconds to complete, depending on the number of next pages sent.

Refer to Clause 28 of the IEEE 802.3u standard for a full description of the individual timers related to Auto-Negotiation.

### 3.5 LED Interfaces

The DP83816 has parallel outputs to indicate the status of Activity (Transmit or Receive), 100 Mb/s Link, and 10 Mb/s Link.

The LEDACTN pin indicates the presence of transmit or receive activity. The standard CMOS driver goes low when RX or TX activity is detected in either 10 Mb/s or 100 Mb/s operation.

The LED100N pin indicates a good link at 100 Mb/s data rate. The standard CMOS driver goes low when this occurs. In 100BASE-T mode, link is established as a result of input receive amplitude compliant with TP-PMD specifications which will result in internal generation of signal detect. This signal will assert after the internal Signal Detect has remained asserted for a minimum of 500 us. The signal will de-assert immediately following the de-assertion of the internal signal detect.

The LED10N pin indicates a good link at 10 Mb/s data rate. The standard CMOS driver goes low when this occurs. 10 Mb/s Link is established as a result of the reception of at least seven consecutive normal Link Pulses or the reception of a valid 10BASE-T packet. This will cause the assertion of this signal. the signal will de-assert in accordance with the Link Loss Timer as specified in IEEE 802.3.

The DP83816 LED pins are capable of 6 mA. Connection of these LED pins should ensure this is not overloaded. Using 2 mA LED devices the connection for the LEDs could be as shown in Figure 3-5.

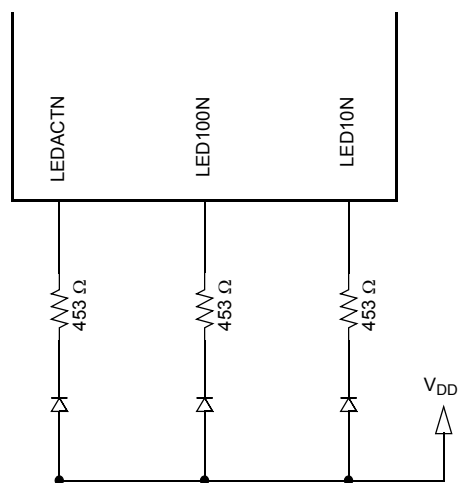

Figure 3-5 LED Loading Example

## 3.0 Functional Description (Continued)

### 3.6 Half Duplex vs. Full Duplex

The DP83816 supports both half and full duplex operation at both 10 Mb/s and 100 Mb/s speeds.

Half-duplex is the standard, traditional mode of operation which relies on the CSMA/CD protocol to handle collisions and network access. In Half-Duplex mode, CRS responds to both transmit and receive activity in order to maintain compliance with IEEE 802.3 specification.

Since the DP83816 is designed to support simultaneous transmit and receive activity it is capable of supporting full-duplex switched applications with a throughput of up to 200 Mb/s per port when operating in 100BASE-TX mode. Because the CSMA/CD protocol does not apply to full-duplex operation, the DP83816 disables its own internal collision sensing and reporting functions.

It is important to understand that while full Auto-Negotiation with the use of Fast Link Pulse code words can interpret and configure to support full-duplex, parallel detection can not recognize the difference between full and half-duplex from a fixed 10 Mb/s or 100 Mb/s link partner over twisted pair. Therefore, as specified in 802.3u, if a far-end link partner is transmitting forced full duplex 100BASE-TX for example, the parallel detection state machine in the receiving station would be unable to detect the full duplex capability of the far-end link partner and would negotiate to a half duplex 100BASE-TX configuration (same scenario for 10 Mb/s).

For full duplex operation, the following register bits must also be set:

- TXCFG:CSI (Carrier Sense Ignore)
- TXCFG:HBI (HeartBeat Ignore)
- RXCFG:ATX (Accept Transmit Packets)

Additionally, the Auto-Negotiation Select bits in the Configuration register must show full duplex support:

- CFG:ANEG\_SEL

### 3.7 Phy Loopback

The DP83816 includes a Phy Loopback Test mode for easy board diagnostics. The Loopback mode is selected through bit 14 (Loopback) of the Basic Mode Control Register (BMCR). Writing 1 to this bit enables transmit data to be routed to the receive path early in the physical layer cell. Loopback status may be checked in bit 3 of the PHY Status Register (C0h). While in Loopback mode the data will not be transmitted onto the media. This is true for either 10 Mb/s as well as 100 Mb/s data.

In 100BASE-TX Loopback mode the data is routed through the PCS and PMA layers into the PMD sublayer before it is

looped back. Therefore, in addition to serving as a board diagnostic, this mode serves as quick functional verification of the device.

Note: A Mac Loopback can be performed via setting bit 29 (Mac Loopback) in the Tx Configuration Register.

### 3.8 Status Information

There are 3 pins that are available to convey status information to the user through LEDs to indicate the speed (10 Mb/s or 100 Mb/s) link status and receive or transmit activity.

10 Mb/s Link is established as a result of the reception of at least seven consecutive Normal Link Pulses or the reception of a valid 10BASE-T packet. LED10N will de-assert in accordance with the Link Loss Timer specified in IEEE 802.3.

100BASE-T Link is established as a result of an input receive amplitude compliant with TP-PMD specifications which will result in internal generation of Signal Detect. LED100N will assert after the internal Signal Detect has remained asserted for a minimum of 500  $\mu$ s. LED100N will de-assert immediately following the de-assertion of the internal Signal Detect.

Activity LED status indicates Receive or Transmit activity.

### 3.9 100BASE-TX TRANSMITTER

The 100BASE-TX transmitter consists of several functional blocks which convert synchronous 4-bit nibble data, to a scrambled MLT-3 125 Mb/s serial data stream. Because the 100BASE-TX TP-PMD is integrated, the differential output pins, TD $\pm$ , can be directly routed to the magnetics.

The block diagram in Figure 3-6 provides an overview of each functional block within the 100BASE-TX transmit section.

The Transmitter section consists of the following functional blocks:

- Code-group Encoder and Injection block (bypass option)
- Scrambler block (bypass option)
- NRZ to NRZI encoder block
- Binary to MLT-3 converter / Common Driver

The bypass option for the functional blocks within the 100BASE-TX transmitter provides flexibility for applications such as 100 Mb/s repeaters where data conversion is not always required. The DP83816 implements the 100BASE-TX transmit state machine diagram as specified in the IEEE 802.3u Standard, Clause 24.

### 3.0 Functional Description (Continued)

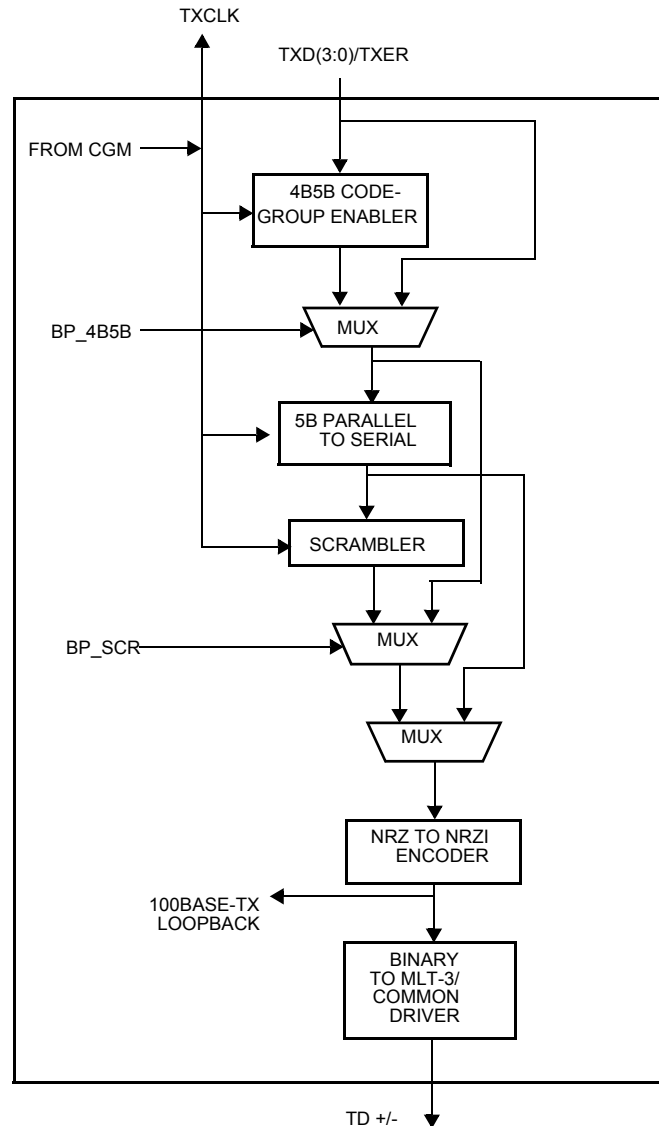

Figure 3-6 100BASE-TX Transmit Block Diagram

#### 3.9.1 Code-group Encoding and Injection

The code-group encoder converts 4-bit (4B) nibble data generated by the MAC into 5-bit (5B) code-groups for transmission. This conversion is required to allow control data to be combined with packet data code-groups. Refer to Table 3-1 for 4B to 5B code-group mapping details.

The code-group encoder substitutes the first 8-bits of the MAC preamble with a J/K code-group pair (11000 10001) upon transmission. The code-group encoder continues to replace subsequent 4B preamble and data nibbles with corresponding 5B code-groups. At the end of the transmit packet, upon the de-assertion of Transmit Enable signal from the MAC, the code-group encoder injects the T/R code-group pair (01101 00111) indicating the end of frame.

After the T/R code-group pair, the code-group encoder continuously injects IDLEs into the transmit data stream until the next transmit packet is detected (re-assertion of Transmit Enable).

#### 3.9.2 Scrambler

The scrambler is required to control the radiated emissions at the media connector and on the twisted pair cable (for 100BASE-TX applications). By scrambling the data, the total energy launched onto the cable is randomly distributed over a wide frequency range. Without the scrambler, energy levels at the PMD and on the cable could peak beyond FCC limitations at frequencies related to repeating 5B sequences (i.e., continuous transmission of IDLEs).

The scrambler is configured as a closed loop linear feedback shift register (LFSR) with an 11-bit polynomial. The output of the closed loop LFSR is X-ORd with the serial NRZ data from the code-group encoder. The result is a scrambled data stream with sufficient randomization to decrease radiated emissions at certain frequencies by as much as 20 dB.

### 3.0 Functional Description (Continued)

#### 3.9.3 NRZ to NRZI Encoder

After the transmit data stream has been serialized and scrambled, the data must be NRZI encoded in order to comply with the TP-PMD standard for 100BASE-TX transmission over Category-5 un-shielded twisted pair cable. There is no ability to bypass this block within the DP83816.

#### 3.9.4 Binary to MLT-3 Converter / Common Driver

The Binary to MLT-3 conversion is accomplished by converting the serial binary data stream output from the NRZI encoder into two binary data streams with alternately phased logic one events. These two binary streams are then fed to the twisted pair output driver which converts the voltage to current and alternately drives either side of the transmit transformer primary winding, resulting in a minimal current (20 mA max) MLT-3 signal. Refer to Figure 3-7

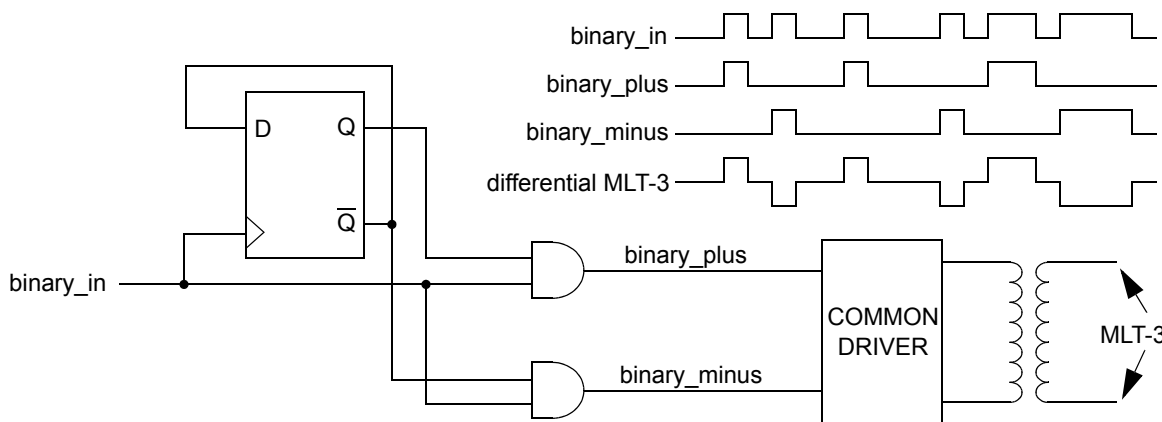

Figure 3-7 Binary to MLT-3 conversion

Table 3-1 4B5B Code-Group Encoding/Decoding

Name	PCS 5B Code-group	Description/4B Value
<b>DATA CODES</b>		
0	11110	0000
1	01001	0001
2	10100	0010
3	10101	0011
4	01010	0100
5	01011	0101
6	01110	0110
7	01111	0111
8	10010	1000
9	10011	1001
A	10110	1010
B	10111	1011
C	11010	1100
D	11011	1101
E	11100	1110
F	11101	1111
<b>IDLE AND CONTROL CODES</b>		
H	00100	HALT code-group - Error code
I	11111	Inter-Packet IDLE - 0000
J	11000	First Start of Packet - 0101
K	10001	Second Start of Packet - 0101
T	01101	First End of Packet - 0000
R	00111	Second End of Packet - 0000

### 3.0 Functional Description (Continued)

**Table 3-1 4B5B Code-Group Encoding/Decoding**

Name	PCS 5B Code-group	Description/4B Value
<b>INVALID CODES</b>		
V	00000	
V	00001	
V	00010	
V	00011	
V	00101	
V	00110	
V	01000	
V	01100	
V	10000	
V	11001	

The 100BASE-TX MLT-3 signal sourced by the TD± common driver output pins is slew rate controlled. This should be considered when selecting AC coupling magnetics to ensure TP-PMD Standard compliant transition times ( $3 \text{ ns} < T_r < 5 \text{ ns}$ ).

The 100BASE-TX transmit TP-PMD function within the DP83816 is capable of sourcing only MLT-3 encoded data. Binary output from the TD± outputs is not possible in 100 Mb/s mode.

#### 3.10 100BASE-TX Receiver

The 100BASE-TX receiver consists of several functional blocks which convert the scrambled MLT-3 125 Mb/s serial data stream to synchronous 4-bit nibble data that is provided to the MAC. Because the 100BASE-TX TP-PMD is integrated, the differential input pins, RD±, can be directly routed from the AC coupling magnetics.

See Figure 3-8 for a block diagram of the 100BASE-TX receive function. This provides an overview of each functional block within the 100BASE-TX receive section.

The Receive section consists of the following functional blocks:

- ADC
- Input and BLW Compensation
- Signal Detect
- Digital Adaptive Equalization
- MLT-3 to Binary Decoder
- Clock Recovery Module
- NRZI to NRZ Decoder
- Serial to Parallel
- De-scrambler (bypass option)
- Code Group Alignment
- 4B/5B Decoder (bypass option)
- Link Integrity Monitor
- Bad SSD Detection

The bypass option for the functional blocks within the 100BASE-TX receiver provides flexibility for applications such as 100 Mb/s repeaters where data conversion is not always required.

#### 3.10.1 Input and Base Line Wander Compensation

Unlike the DP83223V Twister, the DP83816 requires no external attenuation circuitry at its receive inputs, RD+/- . It accepts TP-PMD compliant waveforms directly, requiring only a  $100\Omega$  termination plus a simple 1:1 transformer.

The DP83816 is completely ANSI TP-PMD compliant and includes Base Line Wander (BLW) compensation. The BLW compensation block can successfully recover the TP-PMD defined “killer” pattern and pass it to the digital adaptive equalization block.

BLW can generally be defined as the change in the average DC content, over time, of an AC coupled digital transmission over a given transmission medium. (i.e. copper wire).

BLW results from the interaction between the low frequency components of a transmitted bit stream and the frequency response of the AC coupling component(s) within the transmission system. If the low frequency content of the digital bit stream goes below the low frequency pole of the AC coupling transformers then the droop characteristics of the transformers will dominate resulting in potentially serious BLW.

The digital oscilloscope plot provided in Figure 3-9 illustrates the severity of the BLW event that can theoretically be generated during 100BASE-TX packet transmission. This event consists of approximately 800 mV of DC offset for a period of 120  $\mu\text{s}$ . Left uncompensated, events such as this can cause packet loss.

#### 3.10.2 Signal Detect

The signal detect function of the DP83816 is incorporated to meet the specifications mandated by the ANSI FDDI TP-PMD Standard as well as the IEEE 802.3 100BASE-TX Standard for both voltage thresholds and timing parameters.

Note that the reception of normal 10BASE-T link pulses and fast link pulses per IEEE 802.3u Auto-Negotiation by the 100BASE-TX receiver do not cause the DP83816 to assert signal detect.

### 3.0 Functional Description (Continued)

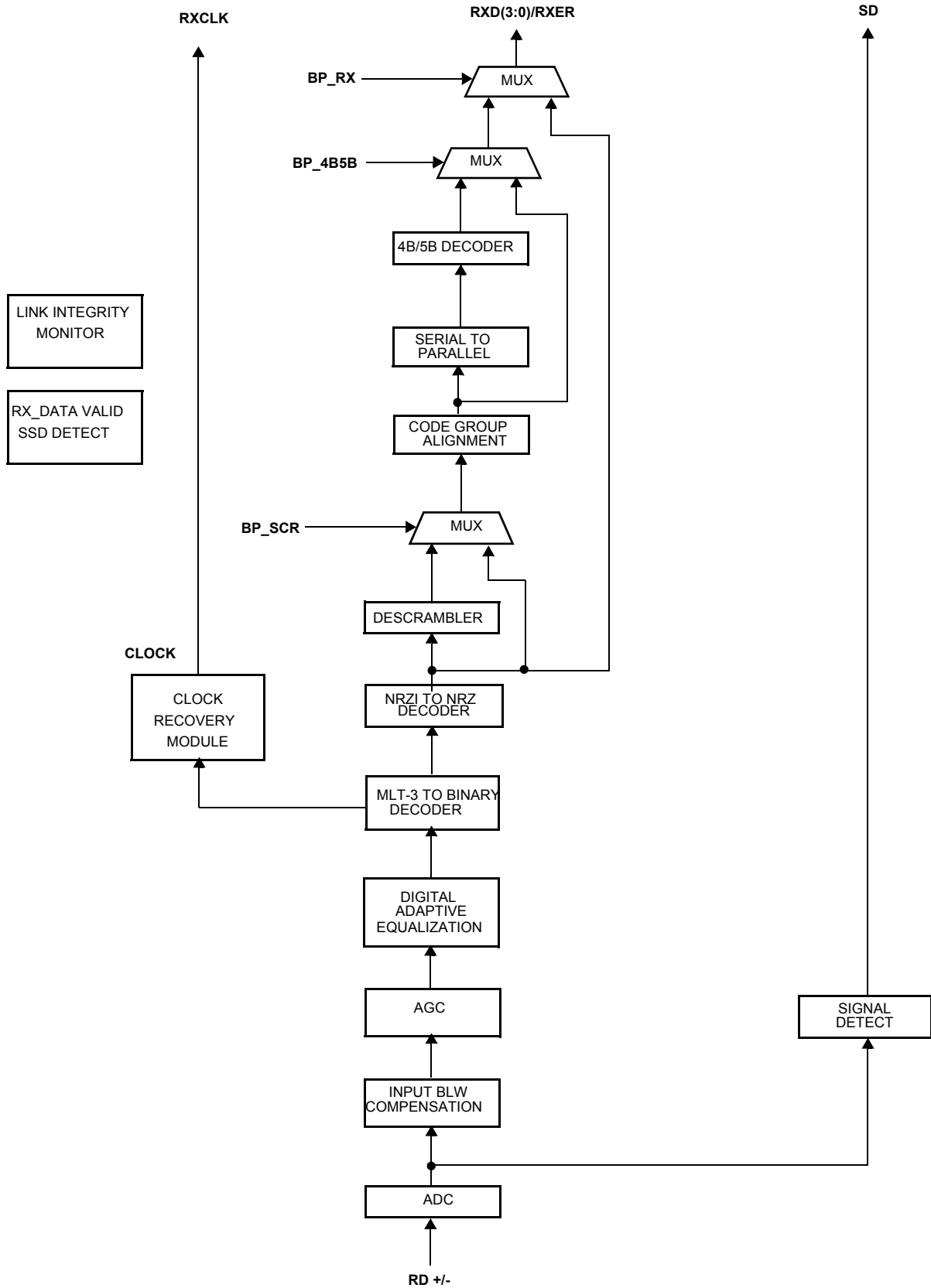

Figure 3-8 100 M/bs Receive Block Diagram

### 3.0 Functional Description (Continued)

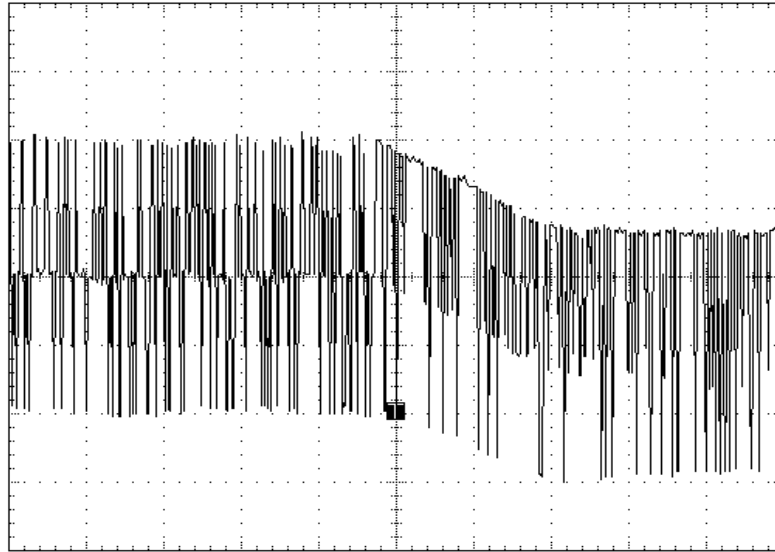

Figure 3-9 100BASE-TX BLW Event Diagram

#### 3.10.3 Digital Adaptive Equalization

When transmitting data at high speeds over copper twisted pair cable, frequency dependent attenuation becomes a concern. In high-speed twisted pair signalling, the frequency content of the transmitted signal can vary greatly during normal operation based primarily on the randomness of the scrambled data stream. This variation in signal attenuation caused by frequency variations must be compensated for to ensure the integrity of the transmission.

In order to ensure quality transmission when employing MLT-3 encoding, the compensation must be able to adapt to various cable lengths and cable types depending on the installed environment. The selection of long cable lengths for a given implementation, requires significant compensation which will over-compensate for shorter, less attenuating lengths. Conversely, the selection of short or intermediate cable lengths requiring less compensation will cause serious under-compensation for longer length cables. Therefore, the compensation or equalization must be adaptive to ensure proper conditioning of the received signal independent of the cable length.

The DP83816 utilizes an extremely robust equalization scheme referred to herein as 'Digital Adaptive Equalization'. Traditional designs use a pseudo adaptive equalization scheme that determines the approximate cable length by monitoring signal attenuation at certain frequencies. This attenuation value was compared to the internal receive input reference voltage. This comparison would indicate the amount of equalization to use. Although this scheme is used successfully on the DP83223V twister,

it is sensitive to transformer mismatch, resistor variation and process induced offset. The DP83223V also required an external attenuation network to help match the incoming signal amplitude to the internal reference.

The Digital Equalizer removes ISI (Inter Symbol Interference) from the receive data stream by continuously adapting to provide a filter with the inverse frequency response of the channel. When used in conjunction with a gain stage, this enables the receive 'eye pattern' to be opened sufficiently to allow very reliable data recovery.

Traditionally 'adaptive' equalizers selected 1 of N filters in an attempt to match the cables characteristics. This approach will typically leave holes at certain cable lengths, where the performance of the equalizer is not optimized. The DP83816 equalizer is truly adaptive.

The curves given in Figure 3-10 illustrate attenuation at certain frequencies for given cable lengths. This is derived from the worst case frequency vs. attenuation figures as specified in the EIA/TIA Bulletin TSB-36. These curves indicate the significant variations in signal attenuation that must be compensated for by the receive adaptive equalization circuit.

Figure 3-11 represents a scrambled IDLE transmitted over zero meters of cable as measured at the AII (Active Input Interface) of the receiver. Figure 3-12 and Figure 3-13 represent the signal degradation over 50 and 100 meters of category V cable respectively, also measured at the AII. These plots show the extreme degradation of signal integrity and indicate the requirement for a robust adaptive equalizer.



### 3.0 Functional Description (Continued)

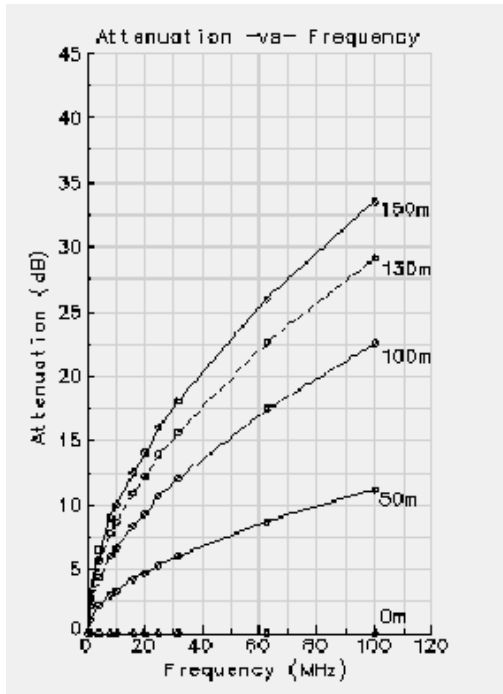

Figure 3-10 EIA/TIA Attenuation vs. Frequency for 0, 50, 100, 130 & 150 meters of CAT V cable

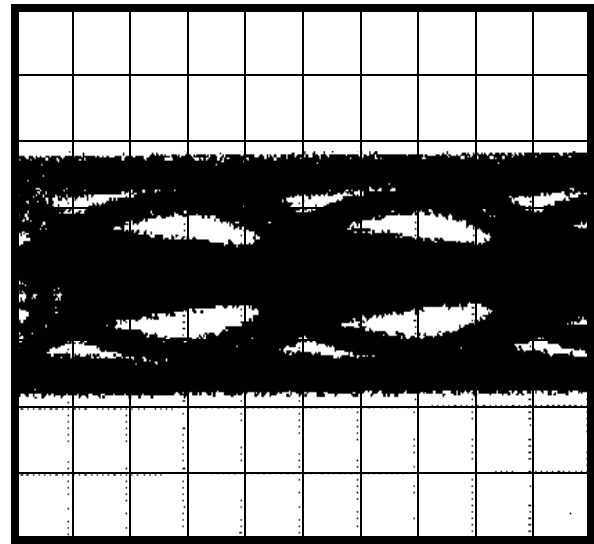

Figure 3-12 MLT-3 Signal Measured at All after 50 meters of CAT V cable

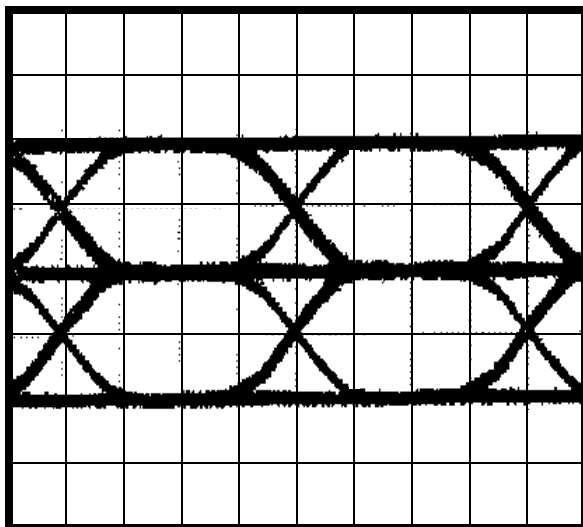

Figure 3-11 MLT-3 Signal Measured at All after 0 meters of CAT V cable

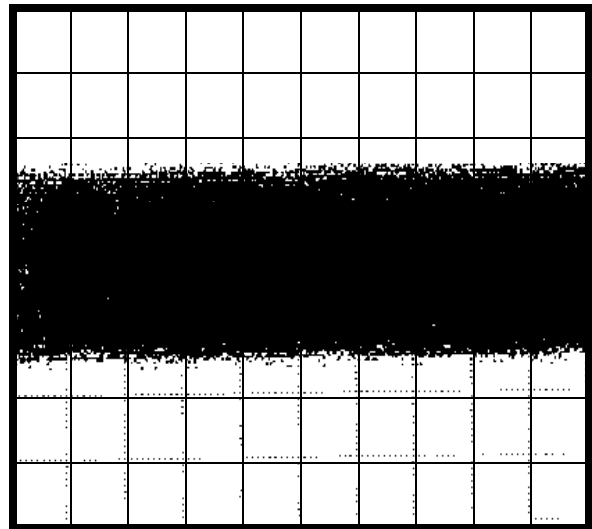

Figure 3-13 MLT-3 Signal Measured at All after 100 meters of CAT V cable

#### 3.10.4 Line Quality Monitor

It is possible to determine the amount of Equalization being used by accessing certain test registers with the DSP engine. This provides a crude indication of connected cable length. This function allows for a quick and simple verification of the line quality in that any significant deviation from an expected register value (based on a known cable length) would indicate that the signal quality has deviated from the expected nominal case.

#### 3.10.5 MLT-3 to NRZI Decoder

The DP83816 decodes the MLT-3 information from the Digital Adaptive Equalizer block to binary NRZI data.

## 3.0 Functional Description (Continued)

### 3.10.6 Clock Recovery Module

The Clock Recovery Module (CRM) accepts 125 Mb/s MLT3 data from the equalizer. The DPLL locks onto the 125 Mb/s data stream and extracts a 125 MHz recovered clock. The extracted and synchronized clock and data are used as required by the synchronous receive operations as generally depicted in Figure 3-8.

The CRM is implemented using an advanced all digital Phase Locked Loop (PLL) architecture that replaces sensitive analog circuitry. Using digital PLL circuitry allows the DP83816 to be manufactured and specified to tighter tolerances.

### 3.10.7 NRZI to NRZ

In a typical application, the NRZI to NRZ decoder is required in order to present NRZ formatted data to the de-scrambler (or to the code-group alignment block, if the de-scrambler is bypassed, or directly to the PCS, if the receiver is bypassed).

### 3.10.8 Serial to Parallel

The 100BASE-TX receiver includes a Serial to Parallel converter which supplies 5-bit wide data symbols to the PCS Rx state machine.

### 3.10.9 De-scrambler

A serial de-scrambler is used to de-scramble the received NRZ data. The de-scrambler has to generate an identical data scrambling sequence (N) in order to recover the original unscrambled data (UD) from the scrambled data (SD) as represented in the equations:

$$SD = (UD \oplus N)$$

$$UD = (SD \oplus N)$$

Synchronization of the de-scrambler to the original scrambling sequence (N) is achieved based on the knowledge that the incoming scrambled data stream consists of scrambled IDLE data. After the de-scrambler has recognized 12 consecutive IDLE code-groups, where an unscrambled IDLE code-group in 5B NRZ is equal to five consecutive ones (11111), it will synchronize to the receive data stream and generate unscrambled data in the form of unaligned 5B code-groups.

In order to maintain synchronization, the de-scrambler must continuously monitor the validity of the unscrambled data that it generates. To ensure this, a line state monitor and a hold timer are used to constantly monitor the synchronization status. Upon synchronization of the de-scrambler the hold timer starts a 722  $\mu$ s countdown. Upon detection of sufficient IDLE code-groups (58 bit times) within the 722  $\mu$ s period, the hold timer will reset and begin a new countdown. This monitoring operation will continue indefinitely given a properly operating network connection with good signal integrity. If the line state monitor does not

recognize sufficient unscrambled IDLE code-groups within the 722  $\mu$ s period, the entire de-scrambler will be forced out of the current state of synchronization and reset in order to re-acquire synchronization.

### 3.10.10 Code-group Alignment

The code-group alignment module operates on unaligned 5-bit data from the de-scrambler (or, if the de-scrambler is bypassed, directly from the NRZI/NRZ decoder) and converts it into 5B code-group data (5 bits). Code-group alignment occurs after the J/K code-group pair is detected. Once the J/K code-group pair (11000 10001) is detected, subsequent data is aligned on a fixed boundary.

### 3.10.11 4B/5B Decoder

The code-group decoder functions as a look up table that translates incoming 5B code-groups into 4B nibbles. The code-group decoder first detects the J/K code-group pair preceded by IDLE code-groups and replaces the J/K with MAC preamble. Specifically, the J/K 10-bit code-group pair is replaced by the nibble pair (0101 0101). All subsequent 5B code-groups are converted to the corresponding 4B nibbles for the duration of the entire packet. This conversion ceases upon the detection of the T/R code-group pair denoting the End of Stream Delimiter (ESD) or with the reception of a minimum of two IDLE code-groups.

### 3.10.12 100BASE-TX Link Integrity Monitor

The 100 Base-TX Link monitor ensures that a valid and stable link is established before enabling both the Transmit and Receive PCS layer.

Signal detect must be valid for 395  $\mu$ s to allow the link monitor to enter the 'Link Up' state, and enable the transmit and receive functions.

Signal detect can be forced active by setting Bit 1 of the PCSR.

Signal detect can be optionally ANDed with the de-scrambler locked indication by setting bit 8 of the PCSR. When this option is enabled, then De-scrambler 'locked' is required to enter the Link Up state, but only Signal detect is required to maintain the link in the link Up state.

### 3.10.13 Bad SSD Detection

A Bad Start of Stream Delimiter (Bad SSD) is any transition from consecutive idle code-groups to non-idle code-groups which is not prefixed by the code-group pair J/K.

If this condition is detected, the DP83816 will assert RXER and present RXD[3:0] = 1110 to the MAC for the cycles that correspond to received 5B code-groups until at least two IDLE code groups are detected. In addition, the False Carrier Event Counter will be incremented by one.

Once at least two IDLE code groups are detected, the error is reported to the MAC.

### 3.0 Functional Description (Continued)

#### 3.11 10BASE-T Transceiver Module

The 10BASE-T Transceiver Module is IEEE 802.3 compliant. It includes the receiver, transmitter, collision, heartbeat, loopback, jabber, and link integrity functions, as defined in the standard. An external filter is not required on the 10BASE-T interface since this is integrated inside the DP83816. This section focuses on the general 10BASE-T system level operation.

##### 3.11.1 Operational Modes

The DP83816 has two basic 10BASE-T operational modes:

- Half Duplex mode - functions as a standard IEEE 802.3 10BASE-T transceiver supporting the CSMA/CD protocol.
- Full Duplex mode - capable of simultaneously transmitting and receiving without reporting a collision. The DP83816's 10 Mb/s ENDEC is designed to encode and decode simultaneously.

##### 3.11.2 Smart Squelch

The smart squelch is responsible for determining when valid data is present on the differential receive inputs ( $RD_{\pm}$ ). The DP83816 implements an intelligent receive squelch to ensure that impulse noise on the receive inputs will not be mistaken for a valid signal. Smart squelch operation is independent of the 10BASE-T operational mode.

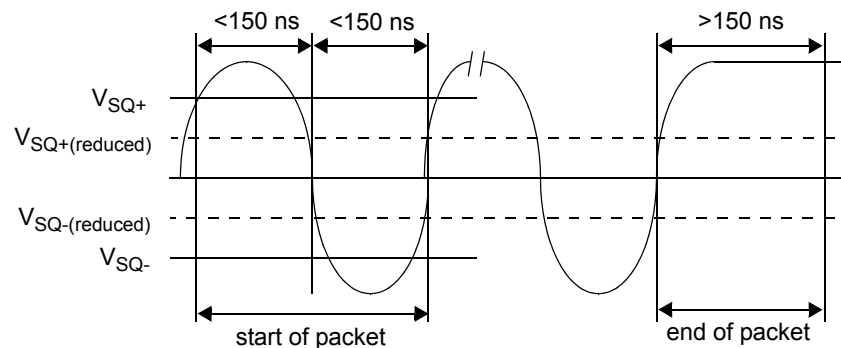

Figure 3-14 10BASE-T Twisted Pair Smart Squelch Operation

##### 3.11.3 Collision Detection

When in Half Duplex, a 10BASE-T collision is detected when the receive and transmit channels are active simultaneously. Collisions are reported to the MAC. Collisions are also reported when a jabber condition is detected.

If the ENDEC is receiving when a collision is detected it is reported immediately (through the COL signal).

When heartbeat is enabled, approximately 1  $\mu$ s after the transmission of each packet, a Signal Quality Error (SQE) signal of approximately 10 bit times is generated to indicate successful transmission.

The SQE test is inhibited when the physical layer is set in full duplex mode. SQE can also be inhibited by setting the HEARTBEAT\_DIS bit in the TBTSR register.

The squelch circuitry employs a combination of amplitude and timing measurements (as specified in the IEEE 802.3 10BASE-T standard) to determine the validity of data on the twisted pair inputs (refer to Figure 3-14).

The signal at the start of packet is checked by the smart squelch and any pulses not exceeding the squelch level (either positive or negative, depending upon polarity) will be rejected. Once this first squelch level is overcome correctly, the opposite squelch level must then be exceeded within 150 ns. Finally the signal must again exceed the original squelch level within a 150 ns to ensure that the input waveform will not be rejected. This checking procedure results in the loss of typically three preamble bits at the beginning of each packet.

Only after all these conditions have been satisfied will a control signal be generated to indicate to the remainder of the circuitry that valid data is present. At this time, the smart squelch circuitry is reset.

Valid data is considered to be present until the squelch level has not been generated for a time longer than 150 ns, indicating the End of Packet. Once good data has been detected the squelch levels are reduced to minimize the effect of noise causing premature End of Packet detection.

##### 3.11.4 Normal Link Pulse Detection/Generation

The link pulse generator produces pulses as defined in the IEEE 802.3 10BASE-T standard. Each link pulse is nominally 100 ns in duration and transmitted every 16 ms in the absence of transmit data.

Link pulses are used to check the integrity of the connection with the remote end. If valid link pulses are not received, the link detector disables the 10BASE-T twisted pair transmitter, receiver and collision detection functions.

When the link integrity function is disabled (FORCE\_LINK\_10 of the TBTSR register), good link is forced and the 10BASE-T transceiver will operate regardless of the presence of link pulses.

## 3.0 Functional Description (Continued)

### 3.11.5 Jabber Function

The jabber function monitors the DP83816's output and disables the transmitter if it attempts to transmit a packet of longer than legal size. A jabber timer monitors the transmitter and disables the transmission if the transmitter is active for approximately 20-30 ms.

Once disabled by the jabber function, the transmitter stays disabled for the entire time that the ENDEC module's internal transmit enable is asserted. This signal has to be de-asserted for approximately 400-600 ms (the "unjab" time) before the jabber function re-enables the transmit outputs.

The Jabber function is only meaningful in 10BASE-T mode.

### 3.11.6 Automatic Link Polarity Detection

The DP83816's 10BASE-T transceiver module incorporates an automatic link polarity detection circuit. When seven consecutive link pulses or three consecutive receive packets with inverted End-of-Packet pulses are received, bad polarity is reported.

A polarity reversal can be caused by a wiring error at either end of the cable, usually at the Main Distribution Frame (MDF) or patch panel in the wiring closet.

The bad polarity condition is latched. The DP83816's 10BASE-T transceiver module corrects for this error internally and will continue to decode received data correctly. This eliminates the need to correct the wiring error immediately.

### 3.11.7 10BASE-T Internal Loopback

When the LOOPBACK bit in the BMCR register is set, 10BASE-T transmit data is looped back in the ENDEC to the receive channel. The transmit drivers and receive input circuitry are disabled in transceiver loopback mode, isolating the transceiver from the network.

Loopback is used for diagnostic testing of the data path through the transceiver without transmitting on the network or being interrupted by receive traffic. This loopback function causes the data to loopback just prior to the 10BASE-T output driver buffers such that the entire transceiver path is tested.

### 3.11.8 Transmit and Receive Filtering

External 10BASE-T filters are not required when using the DP83816, as the required signal conditioning is integrated into the device.

Only isolation/step-up transformers and impedance matching resistors are required for the 10BASE-T transmit and receive interface. The internal transmit filtering ensures that all the harmonics in the transmit signal are attenuated by at least 30 dB.

### 3.11.9 Transmitter

The encoder begins operation when the transmit enable input to the physical layer is asserted and converts NRZ data to pre-emphasized Manchester data for the transceiver. For the duration of assertion, the serialized transmit data is encoded for the transmit-driver pair ( $TD_{\pm}$ ). The last transition is always positive; it occurs at the center of the bit cell if the last bit is a one, or at the end of the bit cell if the last bit is a zero.

### 3.11.10 Receiver

The decoder consists of a differential receiver and a PLL to separate a Manchester encoded data stream into internal

clock signals and data. The differential input must be externally terminated with a differential 100 $\Omega$  termination network to accommodate UTP cable. The internal impedance of  $RD_{\pm}$  (typically 1.1K $\Omega$ ) is in parallel with two 54.9 $\Omega$  resistors to approximate the 100 $\Omega$  termination.

The decoder detects the end of a frame when no more mid-bit transitions are detected.

### 3.11.11 Far End Fault Indication

Auto-Negotiation provides a mechanism for transferring information from the Local Station to the Link Partner that a remote fault has occurred for 100BASE-TX.

A remote fault is an error in the link that one station can detect while the other cannot. An example of this is a disconnected fiber at a station's transmitter. This station will be receiving valid data and detect that the link is good via the Link Integrity Monitor, but will not be able to detect that its transmission is not propagating to the other station.

If three or more FEFI IDLE patterns are detected by the DP83816, then bit 4 of the Basic Mode Status register is set to one until read by management, additionally bit 7 of the PHY Status register is also set.

The first FEFI IDLE pattern may contain more than 84 ones as the pattern may have started during a normal IDLE transmission which is actually quite likely to occur. However, since FEFI is a repeating pattern, this will not cause a problem with the FEFI function. It should be noted that receipt of the FEFI IDLE pattern will not cause a Carrier Sense error to be reported.

If the FEFI function has been disabled via FEFI\_EN (bit 3) of the PCSR Configuration register, then the DP83816 will not send the FEFI IDLE pattern.

## 3.12 802.3u MII

The DP83816 incorporates the Media Independent Interface (MII) as specified in Clause 22 of the IEEE 802.3u standard. This interface may be used to connect PHY devices. This section describes the MII configuration steps as well as the serial MII management interface and nibble wide MII data interface.

### 3.12.1 MII Access Configuration

The DP83816 must be specifically configured for accessing the MII. This is done by first connecting pin 133 (MD1/CFGDISN) to GND through a 1K $\Omega$  resistor. Then setting bit 12 (EXT\_PHY) of the CFG register (offset 04h) to 1. See Section 4.2.2. When this bit is set, the internal Phy is automatically disabled, as reported by bit 9 (PHY\_DIS) of the CFG register. The MII must then be initialized, as described in Section 3.12.4, before the external PHY can be detected.

If external MII is not selected through the register setting as described, then the internal Phy is used and the MII pins of the MacPhyter-II can be left unconnected.

### 3.12.2 MII Serial Management

The MII serial management interface allows for the configuration and control of PHY registers, gathering of status, error information, and the determination of the type and capabilities of the attached PHY(s).

The MII serial management specification defines a set of thirty-two 16-bit status and control registers that are accessible through the management interface pins MDC and MDIO. A description of the serial management interface access and access protocol follows.

### 3.0 Functional Description (Continued)

#### 3.12.3 MII Serial Management Access

Management access to the PHY(s) is done via Management Data Clock (MDC) and Management Data Input/Output (MDIO). MDC has a maximum clock rate of 25 MHz and no minimum rate. The MDIO line is bi-directional and may be shared by up to 32 devices. The internal PHY counts as one of these 32 devices.

The internal PHY has the advantage of having direct register access but can also be controlled exactly like a PHY, with a default address of 1Fh, connected to the MII.

Access and control of the MDC and MDIO pins is done via the MII/EEPROM Access Register (MEAR). The clock (MDC) is created by alternating writes of 0 then 1 to the MDC bit (bit 6). Control of data direction is done by the MDDIR bit (bit 5). Data is either recorded or written by the MDIO bit (bit 4). Setting the MDDIR bit to a 1 allows the DP83816 to drive the MDIO pin. Setting the MDDIR bit to a 0 allows the MDIO bit to reflect the value of the MDIO pin. See Section 4.2.3

This bit-bang access of the MDC and MDIO pins thus requires 64 accesses to the MEAR register to complete a single PHY register transaction. Since a PHY device is typically self configuring and adaptive this serial management access is usually only required at initialization time and therefore is not time critical.

#### 3.12.4 Serial Management Access Protocol

The serial control interface clock (MDC) has a maximum clock rate of 25 MHz and no minimum rate. The MDIO line is bi-directional and may be shared by up to 32 devices. The MDIO frame format is shown in Table 3-2.

If external PHY devices may be attached and removed from the MII there should be a 15 KΩ pull-down resistor on the MDIO signal. If the PHY will always be connected then there should be a 1.5 kΩ pull-up resistor which, during IDLE and turnaround, will pull MDIO high. In order to initialize the MDIO interface, the DP83816 sends a sequence of 32 contiguous logic ones on MDIO provides the PHY(s) with a sequence that can be used to establish synchronization. This preamble may be generated either by driving MDIO high for 32 consecutive MDC clock cycles, or by simply allowing the MDIO pull-up resistor to pull the MDIO pin high during which time 32 MDC clock cycles are provided. In addition 32 MDC clock cycles should be used to re-sync the device if an invalid start, opcode, or turnaround bit is detected.

Table 3-2 Typical MDIO Frame Format

MII Management Serial Protocol	<idle><start><op code><device addr><reg addr><turnaround><data><idle>
Read Operation	<idle><01><10><AAAA><RRRR><Z0><xxxx xxxx xxxx xxxx><idle>
Write Operation	<idle><01><01><AAAA><RRRR><10><xxxx xxxx xxxx xxxx><idle>

The Start code is indicated by a <01> pattern. This assures the MDIO line transitions from the default idle line state.

Turnaround is defined as an idle bit time inserted between the Register Address field and the Data field. To avoid contention during a read transaction, no device shall actively drive the MDIO signal during the first bit of

Turnaround. The addressed PHY drives the MDIO with a zero for the second bit of turnaround and follows this with the required data. Figure 3-15 shows the timing relationship between MDC and the MDIO as driven/received by the DP83816 and a PHY for a typical register read access.

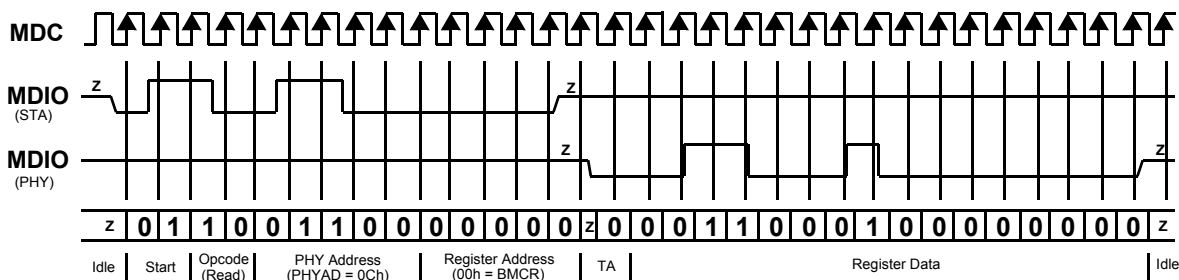

Figure 3-15 Typical MDC/MDIO Read Operation

For write transactions, the DP83816 writes data to the addressed PHY thus eliminating the requirement for MDIO Turnaround. The Turnaround time is filled by the DP83816 by inserting <10>. Figure 3-16 shows the timing relationship for a typical MII register write access.

#### 3.12.5 Nibble-wide MII Data Interface

Clause 22 of the IEEE 802.3u specification defines the Media Independent Interface. This interface include separate dedicated receive and transmit busses. These two data buses, along with various control and indication signals, allow for the simultaneous exchange of data between the DP83816 and PHY(s).

### 3.0 Functional Description (Continued)

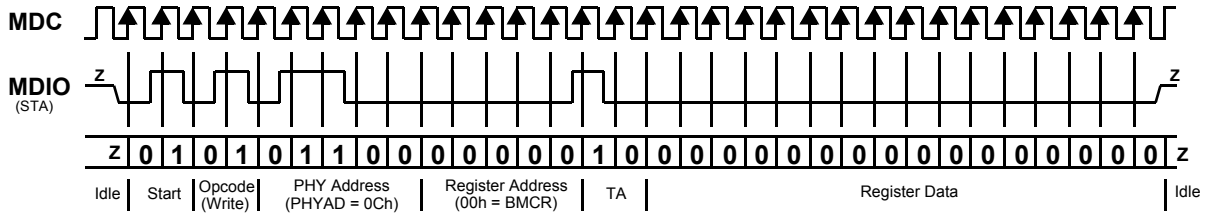

Figure 3-16 Typical MDC/MDIO Write Operation

The receive interface consists of a nibble wide data bus RXD[3:0], a receive error signal RXER, a receive data valid flag RXDV, and a receive clock RXCLK for synchronous transfer of the data. The receive clock can operate at 2.5 MHz to support 10 Mb/s operation modes or at 25 MHz to support 100 Mb/s operational modes.

The transmit interface consists of a nibble wide data bus TXD[3:0], a transmit enable control signal TXEN, and a transmit clock TXCLK which runs at 2.5 MHz or 25 MHz.

Additionally, the MII includes the carrier sense signal CRS, as well as a collision detect signal COL. The CRS signal asserts to indicate the reception of data from the network or as a function of transmit data in Half Duplex mode. The COL signal asserts as an indication of a collision which can occur during half-duplex operation when both a transmit and receive operation occur simultaneously.

#### 3.12.6 Collision Detection

For Half Duplex, a 10BASE-T or 100BASE-TX collision is detected when the receive and transmit channels are active simultaneously. Collisions are reported by the COL signal on the MII.

If the PHY is transmitting in 10 Mb/s mode when a collision is detected, the collision is not reported until seven bits

have been received while in the collision state. This prevents a collision being reported incorrectly due to noise on the network. The COL signal remains set for the duration of the collision.

If a collision occurs during a receive operation, it is immediately reported by the COL signal.

When heartbeat is enabled (only applicable to 10 Mb/s operation), approximately 1µs after the transmission of each packet, a Signal Quality Error (SQE) signal of approximately 10 bit times is generated (internally) to indicate successful transmission. SQE is reported as a pulse on the COL signal of the MII.

#### 3.12.7 Carrier Sense

Carrier Sense (CRS) is asserted due to receive activity, once valid data is detected, during 10 Mb/s operation. During 100 Mb/s operation CRS is asserted when a valid link (SD) and two non-contiguous zeros are detected.

For 10 or 100 Mb/s Half Duplex operation, CRS is asserted during either packet transmission or reception.

For 10 or 100 Mb/s Full Duplex operation, CRS is asserted only due to receive activity.

CRS is de-asserted following an end of packet.

## 4.0 Register Set

### 4.1 Configuration Registers

The DP83816 implements a PCI version 2.2 configuration register space. This allows a PCI BIOS to "soft" configure the DP83816. Software Reset has no effect on configuration registers. Hardware Reset returns all configuration registers to their hardware reset state. For all unused registers, writes are ignored, and reads return 0.

**Table 4-1 Configuration Register Map**

Offset	Tag	Description	Access
00h	CFGID	Configuration Identification Register	RO
04h	CFGCS	Configuration Command and Status Register	R/W
08h	CFGRID	Configuration Revision ID Register	RO
0Ch	CFGLAT	Configuration Latency Timer Register	RO
10h	CFGIOA	Configuration IO Base Address Register	R/W
14h	CFGMA	Configuration Memory Address Register	R/W
18h-28h		Reserved (reads return zero)	
2Ch	CFGSID	Configuration Subsystem Identification Register	RO
30h	CFGROM	Boot ROM configuration register	R/W
34h	CAPPTR	Capabilities Pointer Register	RO
38h		Reserved (reads return zero)	
3Ch	CFGINT	Configuration Interrupt Select Register	R/W
40h	PMCAP	Power Management Capabilities Register	RO
44h	PMCSR	Power Management Control and Status Register	R/W
48-FFh		Reserved (reads return zero)	

#### 4.1.1 Configuration Identification Register

This register identifies the DP83816 Controller to PCI system software.

*Tag:* CFGID                      *Size:* 32 bits                      *Hard Reset:* 0020100Bh  
*Offset:* 00h                      *Access:* Read Only                      *Soft Reset:* Unchanged

Bit	Bit Name	Description
31-16	DEVID	<b>Device ID</b> This field is read-only and is set to the device ID assigned by National Semiconductor to the DP83816, which is 0020h.
15-0	VENID	<b>Vendor ID</b> This field is read-only and is set to a value of 100Bh which is National Semiconductor's PCI Vendor ID.

## 4.0 Register Set (Continued)

### 4.1.2 Configuration Command and Status Register

The CFGCS register has two parts. The upper 16-bits (31-16) are devoted to device status. A status bit is reset whenever the register is written, and the corresponding bit location is a 1. The lower 16-bits (15-0) are devoted to command and are used to configure and control the device.

Tag: CFGCS                      Size: 32 bits                      Hard Reset: 02900000h  
 Offset: 04h                      Access: Read Write                      Soft Reset: Unchanged

Bit	Bit Name	Description
31	DPERR	<b>Detected Parity Error</b> Refer to the description in the PCI V2.2 specification.
30	SSERR	<b>Signaled SERR</b> Refer to the description in the PCI V2.2 specification.
29	RMABT	<b>Received Master Abort</b> Refer to the description in the PCI V2.2 specification.
28	RTABT	<b>Received Target Abort</b> Refer to the description in the PCI V2.2 specification.
27	STABT	<b>Sent Target Abort</b> Refer to the description in the PCI V2.2 specification.
26-25	DSTIM	<b>DEVSELN Timing</b> This field will always be set to 01 indicating that DP83816 supports "medium" DEVSELN timing.
24	DPD	<b>Data Parity Detected</b> Refer to the description in the PCI V2.2 specification.
23	FBB	<b>Fast Back-to-Back Capable</b> DP83816 will set this bit to 1.
22-21		<b>unused</b> (reads return 0)
20	NCPEN	<b>New Capabilities Enable</b> When set, this bit indicates that the Capabilities Pointer contains a valid value and new capabilities such as power management are supported. When clear, new capabilities (CAPPTR, PMCAP, PMCS) are disabled. This bit is loaded from a strap option, MD0 pin 132. A subsequent load of the configuration data from the EEPROM will overwrite any pre-existing value.
19-16		<b>Unused</b> (reads return 0)
15-10		<b>Unused</b> (reads return 0)
9	FBBEN	<b>Fast Back-to-Back Enable</b> Set to 1 by the PCI BIOS to enable the DP83816 to do Fast Back-to-Back transfers (FBB transfers as a master is not implemented in the current revision).
8	SERREN	<b>SERRN Enable</b> When SERREN and PERRSP are set, DP83816 will generate SERRN during target cycles when an address parity error is detected from the system. Also, when SERREN and PERRSP are set and CFG:PESEL is reset, master cycles detecting data parity errors will generate SERRN.
7		<b>Unused</b> (reads return 0)



## 4.0 Register Set (Continued)

Bit	Bit Name	Description
6	PERRSP	<b>Parity Error Response</b> When set, DP83816 will assert PERRN on the detection of a data parity error when acting as the target, and will sample PERRN when acting as the initiator. Also, setting PERRSP allows SERREN to enable the assertion of SERRN. When reset, all address and data parity errors are ignored and neither SERRN nor PERRN are asserted.
5-3		<b>Unused</b> (reads return 0)
2	BMEN	<b>Bus Master Enable</b> When set, DP83816 is allowed to act as a PCI bus master. When reset, DP83816 is prohibited from acting as a PCI bus master.
1	MSEN	<b>Memory Space Address</b> When set, DP83816 responds to memory space accesses. When reset, DP83816 ignores memory space accesses.
0	I/OSEN	<b>I/O Space Access</b> When set, DP83816 responds to I/O space accesses. When reset, DP83816 ignores I/O space accesses.

### 4.1.3 Configuration Revision ID Register

This register stores the silicon revision number, revision number of software interface specification and lets the configuration software know that it is an Ethernet controller in the class of network controllers.

Tag: CFGRID                      Size: 32 bits                      Hard Reset: 02000000h  
 Offset: 08h                      Access: Read Only                      Soft Reset: Unchanged

Bit	Bit Name	Description
31-24	BASECL	<b>Base Class</b> Returns 02h which specifies a network controller.
23-16	SUBCL	<b>Sub Class</b> Returns 00h which specifies an Ethernet controller.
15-8	PROGIF	<b>Programming IF</b> Returns 00h which specifies the first release of the DP83816 Software Interface Specification.
7-0	REVID	<b>Silicon Revision</b> Returns 00h which specifies the silicon revision.

## 4.0 Register Set (Continued)

### 4.1.4 Configuration Latency Timer Register

This register gives status and controls such miscellaneous functions as BIST, Latency timer and Cache line size.

Tag: CFGLAT                      Size: 32 bits                      Hard Reset: 00000000h  
 Offset: 0Ch                      Access: Read Write                      Soft Reset: Unchanged

Bit	Bit Name	Description
31	BISTCAP	<b>BIST Capable</b> Reads will always return 0.
30	BISTEN	<b>BIST Enable</b> Reads will return a 0, writes are ignored.
29-16		<b>Reserved</b> Reads will return a 0, writes are ignored.
15-8	LAT	<b>Latency Timer</b> Set by software to the number of PCI clocks that DP83816 may hold the PCI bus.
7-0	CLS	<b>Cache Line Size</b> Ignored by DP83816.

DP83816 Bus Master Operations:

Independent of cache line size, the DP83816 will use the following PCI commands for bus mastered transfers:

0110 - Mem Read                      for all read cycles,  
 0111 - Mem Write                      for all write cycles.

### 4.1.5 Configuration I/O Base Address Register

This register specifies the Base I/O address which is required to build an address map during configuration. It also specifies the number of bytes required as well as an indication that it can be mapped into I/O space.

Tag: CFGIOA                      Size: 32 bits                      Hard Reset: 00000001h  
 Offset: 10h                      Access: Read Write                      Soft Reset: Unchanged

Bit	Bit Name	Description
31-8	IOBASE	<b>Base I/O Address</b> This is set by software to the base I/O address for the Operational Register Map.
7-2	IOSIZE	<b>Size indication</b> Read back as 0. This allows the PCI bridge to determine that the DP83816 requires 256 bytes of I/O space.
1		<b>Unused</b> (reads return 0).
0	IOIND	<b>I/O Space Indicator</b> Set to 1 by DP83816 to indicate that DP83816 is capable of being mapped into I/O space. Read Only.

## 4.0 Register Set (Continued)

### 4.1.6 Configuration Memory Address Register

This register specifies the Base Memory address which is required to build an address map during configuration. It also specifies the number of bytes required as well as an indication that it can be mapped into memory space.

Tag: CFGMA                      Size: 32 bits                      Hard Reset: 00000000h  
 Offset: 14h                      Access: Read Write                      Soft Reset: unchanged

Bit	Bit Name	Description
31-12	MEMBASE	<b>Memory Base Address</b> This is set by software to the base address for the Operational Register Map.
11-4	MEMSIZE	<b>Memory Size</b> These bits return 0, which indicates that the DP83816 requires 4096 bytes of Memory Space (the minimum recommended allocation).
3	MEMPF	<b>Prefetchable</b> Set to 0 by DP83816. Read Only.
2-1	MEMLOC	<b>Location Selection</b> Set to 00 by DP83816. This indicates that the base register is 32-bits wide and can be placed anywhere in the 32-bit memory space. Read Only.
0	MEMIND	<b>Memory Space Indicator</b> Set to 0 by DP83816 to indicate that DP83816 is capable of being mapped into memory space. Read Only.

### 4.1.7 Configuration Subsystem Identification Register

The CFGSID allows system software to distinguish between different subsystems based on the same PCI silicon. The values in this register can be loaded from the EEPROM if configuration is enabled.

Tag: CFGSID                      Size: 32 bits                      Hard Reset: 00000000h  
 Offset: 2Ch                      Access: Read Only                      Soft Reset: unchanged

Bit	Bit Name	Description
31-16	SDEVID	<b>Subsystem Device ID</b> Set to 0 by DP83816.
15-0	SVENID	<b>Subsystem Vendor ID</b> Set to 0 by DP83816.

## 4.0 Register Set (Continued)

### 4.1.8 Boot ROM Configuration Register

*Tag:* CFGROM                      *Size:* 32 bits                      *Hard Reset:* 00000000h  
*Offset:* 30h                          *Access:* Read Write                      *Soft Reset:* unchanged

Bit	Bit Name	Description
31-16	ROMBASE	<b>ROM Base Address</b> Set to the base address for the boot ROM.
15-11	ROMSIZE	<b>ROM Size</b> Set to 0 indicating a requirement for 64K bytes of Boot ROM space. Read only.
10-1		<b>unused</b> (reads return 0)
0	ROMEN	<b>ROM Enable</b> This is used by the PCI BIOS to enable accesses to boot ROM. This allows the DP83816 to share the address decode logic between the boot ROM and itself. The BIOS will copy the contents of the boot ROM to system RAM before executing it. Set to 1 enables the address decode for boot ROM disabling access to operational target registers.

### 4.1.9 Capabilities Pointer Register

This register stores the capabilities linked list offset into the PCI configuration space.

*Tag:* CAPPTR                          *Size:* 32 bits                          *Hard Reset:* 00000040h  
*Offset:* 34h                          *Access:* Read Only                          *Soft Reset:* unchanged

Bit	Bit Name	Description
31-8		<b>unused</b> (reads return 0)
7-0	CLOFS	<b>Capabilities List Offset</b> Offset into PCI configuration space for the location of the first item in the Capabilities Linked List, set to 40h to point to the PMCAP register.

## 4.0 Register Set (Continued)

### 4.1.10 Configuration Interrupt Select Register

This register stores the interrupt line number as identified by the POST software that is connected to the interrupt controller as well as DP83816 desired settings for maximum latency and minimum grant. Max latency and Min latency can be loaded from the EEPROM.

Tag: CFGINT                      Size: 32 bits                      Hard Reset: 340b0100h  
 Offset: 3Ch                      Access: Read Write                      Soft Reset: unchanged

Bit	Bit Name	Description
31-24	MXLAT	<b>Maximum Latency</b> The DP83816 desired setting for Max Latency. The DP83816 will initialize this field to 52d (13 $\mu$ sec). The value in this register can be loaded from the EEPROM.
23-16	MNGNT	<b>Minimum Grant</b> The DP83816 desired setting for Minimum Grant. The DP83816 will initialize this field to 11d (2.75 $\mu$ sec). The value in this register can be loaded from the EEPROM.
15-8	IPIN	<b>Interrupt Pin</b> Read Only, always return 0000 0001 (INTA).
7-0	ILINE	<b>Interrupt Line</b> Set to which line on the interrupt controller that the DP83816's interrupt pin is connected to.

### 4.1.11 Power Management Capabilities Register

This register provides information on the capabilities of the functions related to power management. This register also contains a pointer to the next item in the capabilities list and the capability ID for Power Management. This register is only visible if CFGCS[4] is set.

Tag: PMCAP                      Size: 32 bits                      Hard Reset: FF820001  
 Offset: 40h                      Access: Read Only                      Soft Reset: unchanged

Bit	Bit Name	Description
31-27	PMES	<b>PME Support</b> This 5 bit field indicates the power states in which DP83816 may assert PMEN. A 1 indicates PMEN is enabled for that state, a 0 indicates PMEN is inhibited in that state. XXXX1 - PMEN can be asserted from state D0 XXX1X - PMEN can be asserted from state D1 XX1XX - PMEN can be asserted from state D2 X1XXX - PMEN can be asserted from state D3hot 1XXXX - PMEN can be asserted from state D3cold The DP83816 will only report PME support for D3cold if auxiliary power is detected on the 3VAUX pin, in addition this value can be loaded from the EEPROM when in the D3cold state.
26	D2S	<b>D2 Support</b> This bit is set to a 1 when the DP83816 supports the D2 state.
25	D1S	<b>D1 Support</b> This bit is set to a 1 when the DP83816 supports the D1 state.

## 4.0 Register Set (Continued)

Bit	Bit Name	Description								
24-22	AUX_CURRENT	<p><b>Aux_Current</b></p> <p>This 3 bit field reports the 3.3Vaux auxiliary current requirements for the PCI function.</p> <p>If PMEN generation from D3cold is not supported by the function(PMCAP[31]), this field returns a value of "000b" when read.</p> <table border="0"> <tr> <td><b>Bit</b></td> <td><b>3.3Vaux</b></td> </tr> <tr> <td><b><u>24 23 22</u></b></td> <td><b><u>Max. Current Required</u></b></td> </tr> <tr> <td>1 1 0</td> <td>320 mA</td> </tr> <tr> <td>0 0 0</td> <td>0 (self powered)</td> </tr> </table>	<b>Bit</b>	<b>3.3Vaux</b>	<b><u>24 23 22</u></b>	<b><u>Max. Current Required</u></b>	1 1 0	320 mA	0 0 0	0 (self powered)
<b>Bit</b>	<b>3.3Vaux</b>									
<b><u>24 23 22</u></b>	<b><u>Max. Current Required</u></b>									
1 1 0	320 mA									
0 0 0	0 (self powered)									
21	DSI	<p><b>Device Specific Initialization</b></p> <p>This bit is set to 1 to indicate to the system that initialization of the DP83816 device is required (beyond the standard PCI configuration header) before the generic class device driver is able to use it. A 1 indicates that DP83816 requires a DSI sequence following transition to the D0 uninitialized state. This bit can be loaded from the EEPROM.</p>								
20		<p><b>Reserved</b></p> <p>(reads return 0)</p>								
19	PMEC	<p><b>PME Clock</b></p> <p>Returns 0 to indicate PCI clock not needed for PMEN.</p>								
18-16	PMV	<p><b>Power Management Version</b></p> <p>This bit field indicates compliance to a specific PM specification rev level. Currently set to 010b.</p>								
15-8	NLIPTR	<p><b>Next List Item Pointer</b></p> <p>Offset into PCI configuration space for the location of the next item in the Capabilities Linked List. Returns 00h as no other capabilities are offered.</p>								
7-0	CAPID	<p><b>Capability ID</b></p> <p>Always returns 01h for Power Management ID.</p>								

### 4.1.12 Power Management Control and Status Register

This register contains PM control and status information.

Tag: PMCSR                      Size: 32 bits                      Hard Reset: 00000000h  
 Offset: 44h                      Access: Read Write                      Soft Reset: unchanged

Bit	Bit Name	Description				
31-24		<p><b>Reserved</b></p> <p>(reads return 0)</p>				
23-16	BSE	<p><b>Bridge Support Extensions</b></p> <p>unused (reads return 0)</p>				
15	PMESTS	<p><b>PME Status</b></p> <p>Sticky bit which represents the state of the PME logic, regardless of the state of the PMEEN bit.</p>				
14-9		<p><b>Reserved</b></p> <p>(reads return 0)</p>				
8	PMEEN	<p><b>PME Enable</b></p> <p>When set to 1, this bit enables the assertion of the PME function on the PMEN pin. When 0, the PMEN pin is forced to be inactive. This value can be loaded from the EEPROM.</p>				
7-2		<p><b>Unused</b></p> <p>(reads return 0)</p>				
1-0	PSTATE	<p><b>Power State</b></p> <p>This 2 bit field is used to determine the current power state of DP83816, and to set a new power state.</p> <table border="0"> <tr> <td>00 - D0</td> <td>10 - D2</td> </tr> <tr> <td>01 - D1</td> <td>11 - D3hot/cold</td> </tr> </table>	00 - D0	10 - D2	01 - D1	11 - D3hot/cold
00 - D0	10 - D2					
01 - D1	11 - D3hot/cold					

## 4.0 Register Set (Continued)

### 4.2 Operational Registers

The DP83816 provides the following set of operational registers mapped into PCI memory space or I/O space. Writes to reserved register locations are ignored. Reads to reserved register locations return undefined values.

**Table 4-2 Operational Register Map**

Offset	Tag	Description	Access
<b>MAC/BIU Registers</b>			
00h	CR	Command Register	R/W
04h	CFG	Configuration Register	R/W
08h	MEAR	EEPROM Access Register	R/W
0Ch	PTSCR	PCI Test Control Register	R/W
10h	ISR	Interrupt Status Register	RO
14h	IMR	Interrupt Mask Register	R/W
18h	IER	Interrupt Enable Register	R/W
1Ch	IHR	Interrupt Holdoff Register	R/W
20h	TXDP	Transmit Descriptor Pointer Register	R/W
24h	TXCFG	Transmit Configuration Register	R/W
28-2Ch	Reserved	Reserved	
30h	RXDP	Receive Descriptor Pointer Register	R/W
34h	RXCFG	Receive Configuration Register	R/W
38	Reserved	Reserved	
3Ch	CCSR	CLKRUN Control/Status Register	R/W
40h	WCSR	Wake on LAN Control/Status Register	R/W
44h	PCR	Pause Control/Status Register	R/W
48h	RFCR	Receive Filter/Match Control Register	R/W
4Ch	RFDR	Receive Filter/Match Data Register	R/W
50h	BRAR	Boot ROM Address	R/W
54h	BRDR	Boot ROM Data	R/W
58h	SRR	Silicon Revision Register	RO
5Ch	MIBC	Management Information Base Control Register	R/W
60-78h	MIB	Management Information Base Data Registers	RO
7Ch	Reserved	Reserved	
<b>Internal Phy Registers</b>			
80h	BMCR	Basic Mode Control Register	R/W
84h	BMSR	Basic Mode Status Register	RO
88h	PHYDR1	PHY Identifier Register #1	RO
8Ch	PHYDR2	PHY Identifier Register #2	RO
90h	ANAR	Auto-Negotiation Advertisement Register	R/W
94h	ANLPAR	Auto-Negotiation Link Partner Ability Register	R/W
98h	ANER	Auto-Negotiation Expansion Register	R/W
9Ch	ANNPTR	Auto-Negotiation Next Page TX	R/W
A0-BCh	Reserved	Reserved	
C0h	PHYSTS	PHY Status Register	RO
C4h	MICR	MII Interrupt Control Register	R/W
C8h	MISR	MII Interrupt Status Register	R/W
CCh	Reserved	Reserved	
D0h	FCSCR	False Carrier Sense Counter Register	R/W
D4h	RECR	Receive Error Counter Register	R/W
D8h	PCSR	100 Mb/s PCS Configuration and Status Register	R/W
DCh-E0h	Reserved	Reserved	
E4h	PHYCR	PHY Control Register	R/W
E8h	TBTSCR	10Base-T Status/Control Register	R/W
ECh-FCh	Reserved	Reserved	





## 4.0 Register Set (Continued)

### 4.2.2 Configuration and Media Status Register

This register allows configuration of a variety of device and phy options, and provides phy status information.

Tag: CFG                                      Size: 32 bits                                      Hard Reset: 00000000h  
Offset: 0004h                                      Access: Read Write                                      Soft Reset: 00000000h

Bit	Bit Name	Description
31	LNKSTS	<b>Link Status</b> Link status of the internal phy. Asserted when link is good. RO
30	SPEED100	<b>Speed 100 Mb/s</b> Speed 100 Mb/s indicator for internal phy. Asserted when speed is set or has negotiated to 100 Mb/s. De-asserted when speed has been set or negotiated to 10 Mb/s. RO
29	FDUP	<b>Full Duplex</b> Full Duplex indicator for internal phy. Asserted when duplex mode is set or has negotiated to FULL. De-asserted when duplex mode has been set or negotiated to HALF. RO
28	POL	<b>10 Mb/s Polarity Indication</b> Twisted pair polarity indicator for internal phy. Asserted when operating and 10 Mb/s and the polarity has been detected as reversed. De-asserted when polarity is normal or phy is operating at 100 Mb/s. RO
27	ANEG_DN	<b>Auto-negotiation Done</b> Auto-negotiation done indicator from internal phy. Asserted when auto-negotiation process has completed or is not active. RO
26-24		<b>unused</b>
23-18	PHY_CFG	<b>Phy Configuration</b> Miscellaneous internal phy Power-On-Reset configuration control bits.
17	PINT_ACEN	<b>Phy Interrupt Auto Clear Enable</b> When set to a 1, this bit allows the phy interrupt source to be automatically cleared whenever the ISR is read. When this bit is 0, the phy interrupt source must be manually cleared via access of the phy registers. R/W
16	PAUSE_ADV	<b>Pause Advertise</b> This bit is loaded from EEPROM at power-up and is used to configure the internal phy to advertise the capability of 802.3x pause during auto-negotiation. Setting this bit to 1 will cause the pause function to be advertised if the phy has also been configured to advertise full duplex capability (See ANEG_SEL). R/W
15-13	ANEG_SEL	<b>Auto-negotiation Select</b> These bits are loaded from EEPROM at power-up and are used to define the default state of the internal phy auto-negotiation logic. R/W These bits are encoded as follows: <ul style="list-style-type: none"> <li>000 Auto-negotiation disabled, force 10 Mb/s half duplex</li> <li>010 Auto-negotiation disabled, force 100 Mb/s half duplex</li> <li>100 Auto-negotiation disabled, force 10 Mb/s full duplex</li> <li>110 Auto-negotiation disabled, force 100 Mb/s full duplex</li> <li>001 Auto-negotiation enabled, advertise 10 Mb/s half &amp; full duplex</li> <li>011 Auto-negotiation enabled, advertise 10/100 Mb/s half duplex</li> <li>101 Auto-negotiation enabled, advertise 100 Mb/s half &amp; full duplex</li> <li>111 Auto-negotiation enabled, advertise 10/100 Mb/s half &amp; full duplex</li> </ul>
12	EXT_PHY	<b>External Phy Support</b> Act as a stand-alone MAC. When set, this bit enables the MII and disables the internal Phy (sets bit 9). R/W
11		<b>Reserved</b>

## 4.0 Register Set (Continued)

Bit	Bit Name	Description
10	PHY_RST	<b>Reset internal Phy</b> Asserts reset to internal phy. Can be used to cause phy to reload options from the CFG register. This bit does not self clear when set. R/W
9	PHY_DIS	<b>Disable internal Phy</b> When set to a 1, this bit forces the internal phy to its low-power state. R/W
8	EUPHCOMP	<b>DP83810 Descriptor Compatibility</b> When set, DP83816 will use DP83810 compatible (but single fragment) descriptor format. Descriptors are four 32-bit words in length, but the fragment count field is ignored. When clear, DP83816 will only fetch 3 32-bit words in descriptor fetches with the third word being the fragment pointer. R/W
7	REQALG	<b>PCI Bus Request Algorithm</b> Selects mode for making requests for the PCI bus. When set to 0 (default), DP83816 will use an aggressive Request scheme. When set to a 1, DP83816 will use a more conservative scheme. R/W
6	SB	<b>Single Back-off</b> Setting this bit to 1 forces the transmitter back-off state machine to always back-off for a single 802.3 slot time instead of following the 802.3 random back-off algorithm. A 0 (default) allows normal transmitter back-off operation. R/W
5	POW	<b>Program Out of Window Timer</b> This bit controls when the <i>Out of Window</i> collision timer begins counting its 512 bit slot time. A 0 causes the timer to start after the SFD is received. A 1 causes the timer to start after the first bit of the preamble is received. R/W
4	EXD	<b>Excessive Deferral Timer disable</b> Setting this bit to 1 will inhibit transmit errors due to excessive deferral. This will inhibit the setting of the ED status, and the logging of the TxExcessiveDeferral MIB counter. R/W
3	PESEL	<b>Parity Error Detection Action</b> This bit controls the assertion of SERR when a data parity error is detected while the DP83816 is acting as the bus master. When set, parity errors <b>will not</b> result in the assertion of SERR. When reset, parity errors <b>will</b> result in the assertion of SERR, indicating a system error. This bit should be set to a one by software if the driver can handle recovery from and reporting of data parity errors. R/W
2	BROM_DIS	<b>Disable Boot ROM interface</b> When set to 1, this bit inhibits the operation of the Boot ROM interface logic. R/W
1		<b>Reserved</b> (reads return 0)
0	BEM	<b>Big Endian Mode</b> When set, DP83816 will perform bus-mastered data transfers in "big endian" mode. Note that access to register space is unaffected by the setting of this bit. R/W

## 4.0 Register Set (Continued)

### 4.2.3 EEPROM Access Register

The EEPROM Access Register provides an interface for software access to the NMC9306 style EEPROM. The default values given assume that the EEDO line has a pullup resistor to VDD.

Tag: MEAR                                  Size: 32 bits                                  Hard Reset: 00000002h  
Offset: 0008h                                  Access: Read Write                                  Soft Reset: 00000002h

Bit	Bit Name	Description
31-7		unused
6	MDC	<b>MII Management Clock</b> Controls the value of the MDC pin. When set, the MDC pin is 1; when clear the MDC pin is 0. R/W
5	MDDIR	<b>MII Management Direction</b> Controls the direction of the MDIO pin. When set, DP83816 drives the MDIO pin. When clear MDIO bit reflects the current state of the MDIO pin. R/W
4	MDIO	<b>MII Management Data</b> Software access to the MDIO pin (see MDDIR above). R/W
3	EESEL	<b>EEPROM Chip Select</b> Controls the value of the EESEL pin. When set, the EESEL pin is 1; when clear the EESEL pin is 0. R/W
2	EECLK	<b>EEPROM Serial Clock</b> Controls the value of the EECLK pin. When set, the EECLK pin is 1; when clear the EECLK pin is 0. R/W
1	EEDO	<b>EEPROM Data Out</b> Returns the current state of the EEDO pin. When set, the EEDO pin is 1; when clear the EEDO pin is 0. RO
0	EEDI	<b>EEPROM Data In</b> Controls the value of the EEDI pin. R/W

### 4.2.4 EEPROM Map

EEPROM Address	Configuration/Operation Register Bits	Default Value (16 bits)
0000h	CFGSID[0:15]	D008h
0001h	CFGSID[16:31]	0400h
0002h	CFGINT[24:31],CFGINT[16:23]	2CD0h
0003h	CFGCS[20],PMCAP[31],PMCAP[21],PMCSR[8],CFG[13:16],CFG[18:23],CR[2], SOPAS[0]	CF82h
0004h	SOPAS[1:16]	0000h
0005h	SOPAS[17:32]	0000h
0006h	SOPAS[33:47],PMATCH[0]	000Nh
0007h	PMATCH[1:16]	NNNNh
0008h	PMATCH[17:32]	NNNNh
0009h	PMATCH[33:47],WCSR[0]	NNNNh
000Ah	WCSR[1:4],WCSR[9:10],RFCR[20],RFCR[22],RFCR[27:31],000b (3 bits)	A098h
000Bh	checksum value	XX55

In the above table:

N denotes the value is dependent on the ethernet MAC ID Number.

X denotes the value is dependent on the checksum value.

## 4.0 Register Set (Continued)

PMATCH[47:0] can be accessed via the combination of the RFCR (offset 0048h) and RFDR (offset 004Ch) registers. PMATCH holds the Ethernet address info. See Section 3.3.3.

The lower 8 bits of the checksum value should be 55h. For the upper 8 bits, add the top 8 data bits to the lower 8 data bits for each address. Sum the resultant 8 bit values for all addresses and then add 55h. Take the 2's complement of the final sum. This 2's complement number should be the upper 8 bits of the checksum value in the last address.

As an example, consider an EEPROM with two addresses. EEPROM address 0000h contains the data 1234h. EEPROM address 0001h contains the data 5678h.

$$12h + 34h = 46h$$

$$56h + 78h = CEh$$

$$46h + CEh + 55h = 69h$$

The 2's complement of 69h is 97h so the checksum value entered into EEPROM address 0002h would be 9755h.

### 4.2.5 PCI Test Control Register

<i>Tag:</i> PTSCR	<i>Size:</i> 32 bits	<i>Hard Reset:</i> 00000000h
<i>Offset:</i> 000Ch	<i>Access:</i> Read Write	<i>Soft Reset:</i> 00000000h

Bit	Bit Name	Description
31-13		unused
12		<b>Reserved for NSC internal use only.</b> Must be written as a 0 otherwise. R/W
11		<b>Reserved</b>
10	RBIST_RST	<b>SRAM BIST Reset</b> Setting this bit to 1 allows the SRAM BIST engine to be reset. R/W
9-8		<b>Reserved for NSC internal use only.</b> Must be written as a 00 otherwise. R/W
7	RBIST_EN	<b>SRAM BIST Enable</b> Setting this bit to 1 starts the SRAM BIST engine. R/W
6	RBIST_DONE	<b>SRAM BIST Done</b> This bit is set to one when the BIST has completed its current test. It is cleared when either the BIST is active or disabled. RO
5	RBIST_RXFAIL	<b>RX FIFO BIST Fail</b> This bit is set to 1 if the SRAM BIST detects a failure in the RX FIFO SRAM. RO
4	RBIST_TXFAIL	<b>TX FIFO Fail</b> This bit is set to 1 if the SRAM BIST detects a failure in the TX FIFO SRAM. RO
3	RBIST_RXFFAIL	<b>RX Filter RAM BIST Fail</b> This bit is set to 1 if the SRAM BIST detects a failure in the RX Filter SRAM. RO
2	EELOAD_EN	<b>Enable EEPROM Load</b> This bit is set to a 1 to manually initiate a load of configuration information from EEPROM. A 1 is returned while the configuration load from EEPROM is active (approx. 1500 us). R/W
1	EEBIST_EN	<b>Enable EEPROM BIST</b> This bit is set to a 1 to initiate EEPROM BIST, which verifies the EEPROM data and checksum without reloading configuration values to the device. A 1 is returned while the EEPROM BIST is active. R/W
0	EEBIST_FAIL	<b>EE BIST Fail indication</b> This bit is set to a 1 upon completion of the EEPROM BIST (EEBIST_EN returns 0) if the BIST logic encountered an invalid checksum. RO



## 4.0 Register Set (Continued)

Bit	Bit Name	Description
7	TXDESC	<b>Tx Descriptor</b> This event is signaled after a transmit descriptor when the INTR bit in the CMDSTS field has been updated.
6	TXOK	<b>Tx Packet OK</b> This event is signaled after the last transmit descriptor in a successful transmission attempt has been updated with valid status.
5	RXORN	<b>Rx Overrun</b> Set when a receive data FIFO overrun condition occurs.
4	RXIDLE	<b>Rx Idle</b> This event is signaled when the receive state machine enters the idle state from a running state. This will happen whenever the state machine encounters an "end-of-list" condition (NULL link field or a descriptor with OWN set).
3	RXEARLY	<b>Rx Early Threshold</b> Indicates that the initial Rx Drain Threshold has been met by the incoming packet, and the transfer of the number of bytes specified by the DRTH field in the RXCFG register has been completed by the receive DMA engine. This interrupt condition will occur only once per packet.
2	RXERR	<b>Rx Packet Error</b> This event is signaled after the last receive descriptor in a failed packet reception has been updated with valid status.
1	RXDESC	<b>Rx Descriptor</b> This event is signaled after a receive descriptor with the INTR bit set in the CMDSTS field has been updated.
0	RXOK	<b>Rx OK</b> Set by the receive state machine following the update of the last receive descriptor in a good packet.

### 4.2.7 Interrupt Mask Register

This register masks the interrupts that can be generated from the ISR. Writing a "1" to the bit enables the corresponding interrupt. During a hardware reset, all mask bits are cleared. Setting a mask bit allows the corresponding bit in the ISR to cause an interrupt. ISR bits are always set to 1, however, if the condition is present, regardless of the state of the corresponding mask bit.

Tag: IMR                                      Size: 32 bits                                      Hard Reset: 00000000h  
Offset: 0014h                                      Access: Read Write                                      Soft Reset: 00000000h

Bit	Bit Name	Description
31-26		<b>unused</b>
25	TXRCMP	<b>Transmit Reset Complete</b> When this bit is 0, the corresponding bit in the ISR will not cause an interrupt.
24	RXRCMP	<b>Receive Reset Complete</b> When this bit is 0, the corresponding bit in the ISR will not cause an interrupt.
23	DPERR	<b>Detected Parity Error</b> When this bit is 0, the corresponding bit in the ISR will not cause an interrupt.
22	SSERR	<b>Signaled System Error</b> When this bit is 0, the corresponding bit in the ISR will not cause an interrupt.
21	RMABT	<b>Received Master Abort</b> When this bit is 0, the corresponding bit in the ISR will not cause an interrupt.

## 4.0 Register Set (Continued)

Bit	Bit Name	Description
20	RTABT	<b>Received Target Abort</b> When this bit is 0, the corresponding bit in the ISR will not cause an interrupt.
19-17		<b>unused</b>
16	RXSOVR	<b>Rx Status FIFO Overrun</b> When this bit is 0, the corresponding bit in the ISR will not cause an interrupt.
15	HIERR	<b>High Bits Error</b> When this bit is 0, the corresponding bit in the ISR will not cause an interrupt.
14	PHY	<b>Phy interrupt</b> When this bit is 0, the corresponding bit in the ISR will not cause an interrupt.
13	PME	<b>Power Management Event</b> When this bit is 0, the corresponding bit in the ISR will not cause an interrupt.
12	SWI	<b>Software Interrupt</b> When this bit is 0, the corresponding bit in the ISR will not cause an interrupt.
11	MIB	<b>MIB Service</b> When this bit is 0, the corresponding bit in the ISR will not cause an interrupt.
10	TXURN	<b>Tx Underrun</b> When this bit is 0, the corresponding bit in the ISR will not cause an interrupt.
9	TXIDLE	<b>Tx Idle</b> When this bit is 0, the corresponding bit in the ISR will not cause an interrupt.
8	TXERR	<b>Tx Packet Error</b> When this bit is 0, the corresponding bit in the ISR will not cause an interrupt.
7	TXDESC	<b>Tx Descriptor</b> When this bit is 0, the corresponding bit in the ISR will not cause an interrupt.
6	TXOK	<b>Tx Packet OK</b> When this bit is 0, the corresponding bit in the ISR will not cause an interrupt.
5	RXORN	<b>Rx Overrun</b> When this bit is 0, the corresponding bit in the ISR will not cause an interrupt.
4	RXIDLE	<b>Rx Idle</b> When this bit is 0, the corresponding bit in the ISR will not cause an interrupt.
3	RXEARLY	<b>Rx Early Threshold</b> When this bit is 0, the corresponding bit in the ISR will not cause an interrupt.
2	RXERR	<b>Rx Packet Error</b> When this bit is 0, the corresponding bit in the ISR will not cause an interrupt.
1	RXDESC	<b>Rx Descriptor</b> When this bit is 0, the corresponding bit in the ISR will not cause an interrupt.
0	RXOK	<b>Rx OK</b> When this bit is 0, the corresponding bit in the ISR will not cause an interrupt.

## 4.0 Register Set (Continued)

### 4.2.8 Interrupt Enable Register

The Interrupt Enable Register controls the hardware INTR signal.

Tag: IER                                      Size: 32 bits                                      Hard Reset: 00000000h  
 Offset: 0018h                                      Access: Read Write                                      Soft Reset: 00000000h

Bit	Bit Name	Description
31-1		unused
0	IE	<b>Interrupt Enable</b> When set to 1, the hardware INTR signal is enabled. When set to 0, the hardware INTR signal will be masked, and no interrupts will be generated. The setting of this bit has no effect on the ISR or IMR. This provides the ability to disable the hardware interrupt to the host with a single access (eliminating the need for a read-modify-write cycle). The actual enabling of interrupts can be delayed based on the Interrupt Holdoff Register defined in the following section. If IE = 0, the interrupt holdoff timer will not start.

### 4.2.9 Interrupt Holdoff Register

The Interrupt Holdoff Register provides interrupt holdoff support. This allows interrupts to be delayed based on a programmable delay timer.

Tag: IHR    Size: 32 bits    Hard Reset: 00000000h  
 Offset: 001Ch    Access: Read Write    Soft Reset: 00000000h

Bit	Bit Name	Description
31-9		unused
8	IHCTL	<b>Interrupt Holdoff Control</b> If this bit is set, the interrupt holdoff timer will start when the first interrupt event occurs and interrupts are enabled. When this bit is not set, the interrupt holdoff timer will start as soon as the timer is loaded and interrupts are enabled. In other words, when not set, the timer will delay the interrupt enable.
7-0	IH	<b>Interrupt Holdoff</b> The register contains a counter value for use in preventing interrupt assertion for a programmed amount of time. When the ISR is read, the interrupt holdoff timer is loaded with this value. It begins to count down to 0 based on the setting of the IHCTL bit. Once it reaches 0, interrupts will be enabled. The counter value is in units of 100 $\mu$ s.

When Interrupts are enabled IE = 1, and IH contains a value other than 00h, IHCTL determines when the Interrupt Holdoff timer will begin its countdown as such:

- IHCTL = 1: The timer does not begin until an interrupt event occurs.  
 The reporting of an interrupt event is delayed for a fixed amount of time from when the interrupt occurs.
- IHCTL = 0: The timer begins immediately without waiting for an interrupt event.  
 The reporting of an interrupt event is delayed for a non-fixed amount of time from when the interrupt occurs.

When IH = 00h (default), there is no delay applied regardless of what IHCTL is set to.



## 4.0 Register Set (Continued)

### 4.2.10 Transmit Descriptor Pointer Register

This register points to the current Transmit Descriptor.

Tag: TXDP                                      Size: 32 bits                                      Hard Reset: 00000000h  
 Offset: 0020h                                      Access: Read Write                                      Soft Reset: 00000000h

Bit	Bit Name	Description
31-2	TXDP	<b>Transmit Descriptor Pointer</b> The current value of the transmit descriptor pointer. When the transmit state machine is idle, software must set TXDP to the address of a completed transmit descriptor. While the transmit state machine is active, TXDP will follow the state machine as it advances through a linked list of active descriptors. If the link field of the current transmit descriptor is NULL (signifying the end of the list), TXDP will not advance, but will remain on the current descriptor. Any subsequent writes to the TXE bit of the CR register will cause the transmit state machine to reread the link field of the current descriptor to check for new descriptors that may have been appended to the end of the list. Transmit descriptors must be aligned on an even 32-bit boundary in host memory (A1-A0 must be 0).
1-0		<b>unused</b>

### 4.2.11 Transmit Configuration Register

This register defines the Transmit Configuration for DP83816. It controls such functions as Loopback, Heartbeat, Auto Transmit Padding, programmable Interframe Gap, Fill & Drain Thresholds, and maximum DMA burst size.

Tag: TXCFG                                      Size: 32 bits                                      Hard Reset: 00040102h  
 Offset: 0024h                                      Access: Read Write                                      Soft Reset: 00040102h

Bit	Bit Name	Description
31	CSI	<b>Carrier Sense Ignore</b> Setting this bit to 1 causes the transmitter to ignore carrier sense activity, which inhibits reporting of CRS status to the transmit status register. When this bit is 0 (default), the transmitter will monitor the CRS signal during transmission and reflect valid status in the transmit status register and MIB counter block. This bit must be set to enable full-duplex operation.
30	HBI	<b>HeartBeat Ignore</b> Setting this bit to 1 causes the transmitter to ignore the heartbeat (CD) pulse which follows the packet transmission and inhibits logging of TXSQEErrors in the MIB counter block. When this bit is set to 0 (default), the transmitter will monitor the heartbeat pulse and log TXSQEErrors to the MIB counter block. This bit must be set to enable full-duplex operation
29	MLB	<b>MAC Loopback</b> Setting this bit to a 1 places the DP83816 MAC into a loopback state which routes all transmit traffic to the receiver, and disables the transmit and receive interfaces of the MII. A 0 in this bit allows normal MAC operation. The transmitter and receiver must be disabled before enabling the loopback mode. (Packets received during MLB mode will reflect loopback status in the receive descriptor's cmdsts.LBP field.)
28	ATP	<b>Automatic Transmit Padding</b> Setting this bit to 1 causes the MAC to automatically pad small (runt) transmit packets to the Ethernet minimum size of 64 bytes. This allows driver software to transfer only actual packet data. Setting this bit to 0 disables the automatic padding function, forcing software to control runt padding.

## 4.0 Register Set (Continued)

Bit	Bit Name	Description
27-26	IFG	<p><b>Interframe Gap Time</b></p> <p>This field allows the user to adjust the interframe gap time below the standard 9.6<math>\mu</math>s @10 Mb/s and 960ns @100 Mb/s. The time can be programmed from 9.6<math>\mu</math>s to 8.4<math>\mu</math>s @10 Mb/s and 960ns to 840ns @100 Mb/s. Note that any value other than zero may violate the IEEE 802.3 standard. The formula for the interframe gap is:</p> <p style="padding-left: 40px;">9.6<math>\mu</math>s - 0.4(IFG[1:0]) <math>\mu</math>s @10 Mb/s and 960ns - 40(IFG[1:0])ns @100 Mb/s</p>
25-24		<p><b>Reserved for NSC internal use only.</b></p> <p>Must be written as a 00 otherwise. R/W</p>
23	ECRETRY	<p><b>Excessive Collision Retry Enable</b></p> <p>This bit enables automatic retries of excessive collisions. If set, the transmitter will retry the packet up to 4 excessive collision counts, for a total of 64 attempts. If the packet still does not complete successfully, then the transmission will be aborted after the 64th attempt. If this bit is not set, then the transmit will be aborted after the 16th attempt. Note that setting this bit will change how collisions are reported in the status field of the transmit descriptor.</p>
22-20	MXDMA	<p><b>Max DMA Burst Size per Tx DMA Burst</b></p> <p>This field sets the maximum size of transmit DMA data bursts according to the following table:</p> <p style="padding-left: 40px;">000 = 128 32-bit words (512 bytes) 001 = 1 32-bit word (4 bytes) 010 = 2 32-bit words (8 bytes) 011 = 4 32-bit words (16 bytes) 100 = 8 32-bit words (32 bytes) 101 = 16 32-bit words (64 bytes) 110 = 32 32-bit words (128 bytes) 111 = 64 32-bit words (256 bytes)</p> <p>NOTE: The MXDMA setting value MUST not be greater than the TXCFG:FLTH (Tx Fill Threshold) value.</p>
19		<b>unused</b>
18		<p><b>Reserved for NSC internal use only.</b></p> <p>Must be set to 1. Setting this bit to 0 selects a non-standard back-off algorithm that could increase the likelihood of excessive collisions.</p>
17-14		<b>unused</b>
13-8	FLTH	<p><b>Tx Fill Threshold</b></p> <p>Specifies the fill threshold in units of 32 bytes. When the number of available bytes in the transmit FIFO reaches this level, the transmit bus master state machine will be allowed to request the PCI bus for transmit packet fragment reads. A value of 0 in this field will produce unexpected results and must not be used.</p> <p>Note: The FLTH value should be greater than the TXCFG:MXDMA value, but less than (txFIFOsize - TXCFG:DRTH). In order to prevent FIFO pointer overlap internal to the device, the sum of the FLTH and TXCFG:DRTH values should not exceed 2016 Bytes.</p>
7-6		<b>unused</b>
5-0	DRTH	<p><b>Tx Drain Threshold</b></p> <p>Specifies the drain threshold in units of 32 bytes. When the number of bytes in the FIFO reaches this level (or the FIFO contains at least one complete packet) the MAC transmit state machine will begin the transmission of a packet.</p> <p>NOTE: In order to prevent a deadlock condition from occurring, the DRTH value should always be less than (txFIFOsize - TXCFG:FLTH). A value of 0 in this field will produce unexpected results and must not be used. Also, in order to prevent FIFO pointer overlap internal to the device, the sum of the DRTH and TXCFG:FLTH values should not exceed 2016 Bytes.</p>

## 4.0 Register Set (Continued)

### 4.2.12 Receive Descriptor Pointer Register

This register points to the current Receive Descriptor.

*Tag:* RXDP                      *Size:* 32 bits                      *Hard Reset:* 00000000h  
*Offset:* 0030h                      *Access:* Read Write                      *Soft Reset:* 00000000h

Bit	Bit Name	Description
31-2	RXDP	<b>Receive Descriptor Pointer</b> The current value of the receive descriptor pointer. When the receive state machine is idle, software must set RXDP to the address of an available receive descriptor. While the receive state machine is active, RXDP will follow the state machine as it advances through a linked list of available descriptors. If the link field of the current receive descriptor is NULL (signifying the end of the list), RXDP will not advance, but will remain on the current descriptor. Any subsequent writes to the RXE bit of the CR register will cause the receive state machine to reread the link field of the current descriptor to check for new descriptors that may have been appended to the end of the list. Software should not write to this register unless the receive state machine is idle. Receive descriptors must be aligned on 32-bit boundaries (A1-A0 must be zero). A 0 written to RXDP followed by a subsequent write to RXE will cause the receiver to enter silent RX mode, for use during WOL. In this mode packets will be received and buffered in FIFO, but no DMA to system memory will occur. The packet data may be recovered from the FIFO by writing a valid descriptor address to RXDP and then strobing RXE.
1-0		<b>unused</b>

## 4.0 Register Set (Continued)

### 4.2.13 Receive Configuration Register

This register is used to set the receive configuration for DP83816. Receive properties such as accepting error packets, runt packets, setting the receive drain threshold etc. are controlled here.

Tag: RXCFG                      Size: 32 bits                      Hard Reset: 00000002h  
 Offset: 0034h                      Access: Read Write                      Soft Reset: 00000002h

Bit	Bit Name	Description
31	AEP	<b>Accept Errored Packets</b> When set to 1, all packets with CRC, alignment, and/or collision errors will be accepted. When set to 0, all packets with CRC, alignment, and/or collision errors will be rejected if possible. Note that depending on the type of error, some packets may be received with errors, regardless of the setting of AEP. These errors will be indicated in the CMDSTS field of the last descriptor in the packet.
30	ARP	<b>Accept Runt Packets</b> When set to 1, all packets under 64 bytes in length without errors are accepted. When this bit is 0, all packets less than 64 bytes in length will be rejected if possible.
29		<b>unused</b>
28	ATX	<b>Accept Transmit Packets</b> When set to 1, data received simultaneously to a local transmission (such as during a PMD loopback or full duplex operation) will be accepted as valid received data. Additionally, when set to 1, the receiver will ignore collision activity. When set to 0 (default), all data receive simultaneous to a local transmit will be rejected. This bit must be set to 1 for PMD loopback and full duplex operation.
27	ALP	<b>Accept Long Packets</b> When set to 1, all packets > 1518 bytes in length and <= 2046 bytes will be treated as normal receive packets, and will not be tagged as long or error packets. All packets > 2046 bytes in length will be truncated at 2046 bytes and either rejected from the FIFO, or tagged as long packets. Care must be taken when accepting long packets to ensure that buffers provided are of adequate length. When ALP is set to 0, packets larger than 1518 bytes (CRC inclusive) will be truncated at 1514 bytes, and rejected if possible.
26		<b>unused</b>
25-23		<b>unused</b> Writes are ignored, reads return 000b.
22-20	MXDMA	<b>Max DMA Burst Size per Rx DMA Burst</b> This field sets the maximum size of receive DMA data bursts according to the following table: 000 = 128 32-bit words (512 bytes) 001 = 1 32-bit word (4 bytes) 010 = 2 32-bit words (8 bytes) 011 = 4 32-bit words (16 bytes) 100 = 8 32-bit words (32 bytes) 101 = 16 32-bit words (64 bytes) 110 = 32 32-bit words (128 bytes) 111 = 64 32-bit words (256 bytes)
19-6		<b>unused</b>

## 4.0 Register Set (Continued)

Bit	Bit Name	Description
5-1	DRTH	<p><b>Rx Drain Threshold</b></p> <p>Specifies the drain threshold in units of 8 bytes. When the number of bytes in the receive FIFO reaches this value (times 8), or the FIFO contains a complete packet, the receive bus master state machine will begin the transfer of data from the FIFO to host memory. Care must be taken when setting DRTH to a value lower than the number of bytes needed to determine if packet should be accepted or rejected. In this case, the packet might be rejected after the bus master operation to begin transferring the packet into memory has begun. When this occurs, neither the OK bit or any error status bit in the descriptor's cmdsts will be set. A value of 0 is illegal, and the results are undefined.</p> <p>This value is also used to compare with the accumulated packet length for early receive indication. When the accumulated packet length meets or exceeds the DRTH value, the RXEARLY interrupt condition is generated.</p>
0		<b>Reserved</b>

### 4.2.14 CLKRUN Control/Status Register

This register mirrors the read/write control of the PMESTS and PMEEN from the PCI Configuration register PMCSR and controls whether the chip is in the CLKRUNN or PMEN mode.

Tag: CCSR                      Size: 32 bits                      Hard Reset: 00000000h  
 Offset: 003Ch                      Access: Read Write                      Soft Reset: unchanged

Bit	Bit Name	Description
31-16		<p><b>reserved</b></p> <p>(reads return 0)</p>
15	PMESTS	<p><b>PME Status</b></p> <p>Sticky bit which represents the state of the PME/CLKRUN logic, regardless of the state of the PMEEN bit. Mirrored from PCI configuration register PMCSR. Writing a 1 to this bit clears it.</p>
14-9		<p><b>reserved</b></p> <p>(reads return 0)</p>
8	PMEEN	<p><b>PME Enable</b></p> <p>When set to 1, this bit enables the assertion of the PMEN/CLKRUNN pin. When 0, the PMEN/CLKRUNN pin is forced to be inactive. This value can be loaded from the EEPROM. Mirrored from PCI configuration register PMCSR.</p>
7-1		<p><b>unused</b></p> <p>(reads return 0)</p>
0	CLKRUN_EN	<p><b>Clkrun Enable</b></p> <p>When set to 1, this bit enables the CLKRUNN functionality of the PMEN/CLKRUNN pin. When 0, normal PMEN functionality is active.</p>

## 4.0 Register Set (Continued)

### 4.2.14.1 CLKRUNN Function

CLKRUNN is a dual-function optional signal. It is used by the central PCI clock resource to indicate clock status (i.e. PCI clock running normally or slowed/stopped), and it is used by PCI devices to request that the central resource restart the PCI clock or keep it running normally.

In the DP83816, CLKRUNN shares a pin with PMEN (pin 59). This means the chip cannot be simultaneously PCI Power Management and PCI Mobile Design Guide-compliant; however, it is unlikely that a system would use both of these functions simultaneously. The function of the PMEN/CLKRUNN pin is selected with the CLKRUN\_EN bit of CCSR.

CCSR bits 15 and 8 (PMESTS and PMEEN) are mirrored from PCI configuration space to allow them to be accessed by software. The functionality of these bits is the same as in the PCI configuration register PMCSR.

As an output, CLKRUNN is open-drain like PMEN, i.e. it can only drive low. CLKRUNN is an input unless one of the following two conditions occurs:

1. the system drives CLKRUNN high but the DP83816 is not ready for the PCI clock to be stopped or
2. the PCI clock is stopped or slowed (CLKRUNN is pulled high by the system) and the DP83816 requires the use of the PCI bus.

Situation 1 is a “clock continue” event and can occur if the DP83816 has not completed a pending packet transmit or receive. Situation 2 is a “clock start” event and can occur if the DP83816 has been programmed to a WOL state and it receives a wake packet, or the PCI clock has simply been stopped and the receiver has data ready to DMA. In either of these situations, the DP83816 asserts CLKRUNN until it detects two rising edges of the PCI clock; it then releases assertion of CLKRUNN. At this point, the central resource is driving CLKRUNN low, and cannot drive it high again until at least four rising edges of the PCI clock have occurred since the initial CLKRUNN assertion by the DP83816. Also in either situation, the DP83816 must have detected CLKRUNN de-asserted for two consecutive rising edges of the PCI clock before it is allowed to assert CLKRUNN.

#### NOTES:

- \* If a clock start or continue event has completed but a PCI interrupt has not been serviced yet, the CLKRUNN logic will not prevent the system from stopping the PCI clock.
- \* If PMEEN is not set, the DP83816 cannot assert CLKRUNN to request a clock start or continue. In this case, if the system is going to stop the PCI clock, software must shut down the internal PHY to prevent receive errors.
- \* If another CLKRUN-enabled device in the system encounters a clock start or continue event, the cycle of assertions and de-assertions of CLKRUNN will cause the DP83816 clock mux to switch the clock to the RX block back and forth between the PCI clock and the X1 clock until the event completes.

## 4.0 Register Set (Continued)

### 4.2.15 Wake Command/Status Register

The WCSR register is used to configure/control and monitor the DP83816 Wake On LAN logic. The Wake On LAN logic is used to monitor the incoming packet stream while in a low-power state, and provide a wake event to the system if the desired packet type, contents, or Link change are detected.

*Tag:* WCSR                              *Size:* 32 bits                              *Hard Reset:* 00000000h  
*Offset:* 0040h                              *Access:* Read Write                              *Soft Reset:* 00000000h

Bit	Bit Name	Description
31	MPR	<b>Magic Packet™ Received</b> Set to 1 if a Magic Packet™ has been detected and the WKMAG bit is set. RO, cleared on read.
30	PATM3	<b>Pattern 3 match</b> Associated bit set to 1 if a pattern 3 match is detected and the WKPAT3 bit is set. RO, cleared on read.
29	PATM2	<b>Pattern 2 match</b> Associated bit set to 1 if a pattern 2 match is detected and the WKPAT2 bit is set. RO, cleared on read.
28	PATM1	<b>Pattern 1 match</b> Associated bit set to 1 if a pattern 1 match is detected and the WKPAT1 bit is set. RO, cleared on read.
27	PATM0	<b>Pattern 0 match</b> Associated bit set to 1 if a pattern 0 match is detected and the WKPAT0 bit is set. RO, cleared on read.
26	ARPR	<b>ARP Received</b> Set to 1 if an ARP packet has been detected and the WKARP bit is set. RO, cleared on read.
25	BCASTR	<b>Broadcast Received</b> Set to 1 if a broadcast packet has been detected and the WKBCP bit is set. RO, cleared on read.
24	MCASTR	<b>Multicast Received</b> Set to 1 if a multicast packet has been detected and the WKMCP bit is set. RO, cleared on read.
23	UCASTR	<b>Unicast Received</b> Set to 1 if a unicast packet has been detected the WKUCP bit is set. RO, cleared on read.
22	PHYINT	<b>Phy Interrupt</b> Set to 1 if a Phy interrupt was detected and the WKPHY bit is set. RO, cleared on read.
21	Reserved	<b>Reserved</b> RO, cleared on read.
20	SOHACK	<b>SecureOn Hack Attempt</b> Set to 1 if the MPSOE and WKMAG bits are set, and a Magic Packet™ is receive with an invalid SecureOn password value. RO, Cleared on read.
19-11		<b>unused</b> returns 0
10	MPSOE	<b>Magic Packet™ SecureOn Enable</b> Enable Magic Packet™ SecureOn feature. Only applicable when bit 9 is set. R/W
9	WKMAG	<b>Wake on Magic Packet™</b> Enable wake on Magic Packet™ detection. R/W
8	WKPAT3	<b>Wake on Pattern 3 match</b> Enable wake on match of pattern 3. R/W
7	WKPAT2	<b>Wake on Pattern 2 match</b> Enable wake on match of pattern 2. R/W
6	WKPAT1	<b>Wake on Pattern 1 match</b> Enable wake on match of pattern 1. R/W

## 4.0 Register Set (Continued)

Bit	Bit Name	Description
5	WKPAT0	<b>Wake on Pattern 0 match</b> Enable wake on match of pattern 0. R/W
4	WKARP	<b>Wake on ARP</b> Enable wake on ARP packet detection. R/W
3	WKBCP	<b>Wake on Broadcast</b> Enable wake on broadcast packet detection. R/W
2	WKMCP	<b>Wake on Multicast</b> Enable wake on multicast packet detection. R/W
1	WKUCP	<b>Wake on Unicast</b> Enable wake on unicast packet detection. R/W
0	WKPHY	<b>Wake on Phy Interrupt</b> Enable wake on Phy Interrupt. The Phy interrupt can be programmed for Link Change and a variety of other Physical Layer events. R/W

### 4.2.15.1 Wake on LAN

The Wake on LAN logic provides several mechanisms for bringing the DP83816 out of a low-power state. Wake on ARP, Wake on Broadcast, Wake on Multicast Hash and Wake on Phy Interrupt are enabled by setting the corresponding bit in the Wake Command/Status Register, WCSR. Before the hardware is programmed to a low power state, the software must write a null receive descriptor pointer to the Receive Descriptor Pointer Register (RXDP) to ensure wake packets will be buffered in the RX fifo. Please refer to the description of the RXDP register for this procedure.

When a qualifying packet is received, the Wake on LAN logic generates a Wake event and pulses the PMEN PCI signal to request a Power Management state change. The software must then bring the hardware out of low power mode and, if the Power Management state was D3hot, reinitialize Configuration Register space. A Wake interrupt can also be generated which alerts the software that a Wake event has occurred and a packet was received. The software must then write a valid receive descriptor pointer to RXDP. The incoming packet can then be transferred into

host memory for processing. Note that the wake packet is retained for processing - this is a feature of the DP83816. In addition to the above Wake on LAN features, DP83816 also provides Wake on Pattern Matching, Wake on DA match and Wake on Magic Packet™.

#### Wake on Pattern Matching

Wake on Pattern Matching is an extension of the Pattern Matching feature provided by the Receive Filter Logic. When one or more of the Wake on Pattern Match bits are set in the WCSR, a packet will generate a wake event if it matches the associated pattern buffer. The pattern count and the pattern buffer memory are accessed in the same way as in Pattern Matching for packet acceptance. The minimum pattern count is 2 bytes and the maximum pattern count is 64 bytes for patterns 0 and 1, and 128 bytes for patterns 2 and 3. Packets are compared on a byte by byte basis and bytes may be masked in pattern memory, thus allowing for don't cares. Refer to Section 4.2.19 Receive Filter Logic for programming examples.



## 4.0 Register Set (Continued)

### 4.2.16 Pause Control/Status Register

The PCR register is used to control and monitor the DP83816 Pause Frame reception logic. The Pause Frame reception Logic is used to accept 802.3x Pause Frames, extract the pause length value, and initiate a TX MAC pause interval of the specified number of slot times.

Tag: PCR                                      Size: 32 bits                                      Hard Reset: 00000000h  
 Offset: 0044h                                      Access: Read Write                                      Soft Reset: 00000000h

Bit	Bit Name	Description
31	PSEN	<b>Pause Enable</b> Manually enables reception of 802.3x pause frames This bit is ORed with the PSNEG bit to enable pause reception. If pause reception has been enabled via PSEN bit (PSEN=1), setting this bit to 0 will cause any active pause interval to be terminated. R/W
30	PS_MCAST	<b>Pause on Multicast</b> When set to 1, this bit enables reception of 802.3x pause frames which use the 802.3x designated multicast address in the DA (01-80-C2-00-00-01). When this mode is enabled, the RX filter logic performs a perfect match on the above multicast address. No other address filtration modes (including multicast hash) are required for pause frame reception. R/W
29	PS_DA	<b>Pause on DA</b> When set to 1, this bit enables reception of a pause frame based on a DA match with either the perfect match register, or one of the pattern match buffers. R/W
28-24		<b>unused</b> returns 0
23	PS_ACT	<b>Pause Active</b> This bit is set to a 1 when the TX MAC logic is actively timing a pause interval. RO
22	PS_RCVD	<b>Pause Frame Received</b> This bit is set to a 1 when a pause frame has been received. This bit will remain set until the TX MAC has completed the pause interval. RO
21	PSNEG	<b>Pause Negotiated</b> Status bit indicating that the 802.3x pause function has been enabled via auto-negotiation. This bit will only be set if DP83816 advertises pause capable by setting bit 16 in the CFG register. RO
20-17		<b>unused</b> returns 0
16	MLD_EN	<b>Manual Load Enable</b> Setting this bit to a 1 will cause the value of bits 15-0 to be written to the pause count register. This write operation causes pause count interval to be manually initiated. This bit is not sticky, and reads will always return 0. WO
15-0	PAUSE_CNT	<b>Pause Counter Value</b> READ: These bits represent the current real-time value of the TX MAC pause counter register. WRITE: If no pause count interval is in progress (PS_RCVD=0, PS_ACT=0), and MLD_EN=1 this value is written to the pause count register, and causes pause count interval to be manually initiated.

## 4.0 Register Set (Continued)

### 4.2.17 Receive Filter/Match Control Register

The RFCR register is used to control and configure the DP83816 Receive Filter Control logic. The Receive Filter Control Logic is used to configure destination address filtering of incoming packets.

Tag: RFCR                      Size: 32 bits                      Hard Reset: 00000000h  
 Offset: 0048h                      Access: Read Write                      Soft Reset: 00000000h

Bit	Bit Name	Description
31	RFEN	<b>Rx Filter Enable</b> When this bit is set to 1, the Rx Filter is enabled to qualify incoming packets. When set to a 0, receive packet filtering is disabled (i.e. all receive packets are rejected). This bit must be 0 for the other bits in this register to be configured.
30	AAB	<b>Accept All Broadcast</b> When set to a 1, this bit causes all broadcast address packets to be accepted. When set to 0, no broadcast address packets will be accepted.
29	AAM	<b>Accept All Multicast</b> When set to a 1, this bit causes all multicast address packets to be accepted. When set to 0, multicast destination addresses must have the appropriate bit set in the multicast hash table mask in order for the packet to be accepted.
28	AAU	<b>Accept All Unicast</b> When set to a 1, this bit causes all unicast address packets to be accepted. When set to 0, the destination address must match the node address value specified through some other means in order for the packet to be accepted.
27	APM	<b>Accept on Perfect Match</b> When set to 1, this bit allows the perfect match register to be used to compare against the DA for packet acceptance. When this bit is 0, the perfect match register contents will not be used for DA comparison.
26-23	APAT	<b>Accept on Pattern Match</b> When one or more of these bits is set to 1, a packet will be accepted if the first n bytes (n is the value defined in the associated pattern count register) match the associated pattern buffer memory contents. When a bit is set to 0, the associated pattern buffer will not be used for packet acceptance.
22	AARP	<b>Accept ARP Packets</b> When set to 1, this bit allows all ARP packets (packets with a TYPE/LEN field set to 806h) to be accepted, regardless of the DA value. When set to 0, ARP packets are treated as normal packets and must meet other DA match criteria for acceptance.
21	MHEN	<b>Multicast Hash Enable</b> When set to 1, this bit allows hash table comparison for multicast addresses, i.e. a hash table hit for a multicast addressed packet will be accepted. When set to 0, multicast hash hits will not be used for packet acceptance.
20	UHEN	<b>Unicast Hash Enable</b> When set to 1, this bit allows hash table comparison for unicast addresses, i.e. a hash table hit for a unicast addressed packet will be accepted. When set to 0, unicast hash hits will not be used for packet acceptance.
19	ULM	<b>U/L bit Mask</b> When set to 1, this bit will cause the U/L bit (2nd MSb) of the DA to be ignored during comparison with the perfect match register.
18-10		<b>Unused</b> returns 0

## 4.0 Register Set (Continued)

Bit	Bit Name	Description
9-0	RFADDR	<b>Receive Filter Extended Register Address</b> Selects which internal receive filter register is accessible via RFDR: Perfect Match Register (PMATCH) 000h - PMATCH octets 1-0 002h - PMATCH octets 3-2 004h - PMATCH octets 5-4 Pattern Count Registers (PCOUNT) 006h - PCOUNT1, PCOUNT0 008h - PCOUNT3, PCOUNT2 SecureOn Password Register (SOPAS) 00Ah - SOPAS octets 1-0 00Ch - SOPAS octets 3-2 00Eh - SOPAS octets 5-4 Filter Memory 200h-3FE - Rx filter memory (Hash table/pattern buffers)

### 4.2.18 Receive Filter/Match Data Register

The RFDR register is used for reading from and writing to the internal receive filter registers, the pattern buffer memory, and the hash table memory.

*Tag:* RFDR                      *Size:* 32 bits                      *Hard Reset:* 00000000h  
*Offset:* 004Ch                      *Access:* Read Write                      *Soft Reset:* 00000000h

Bit	Bit Name	Description
31-18		<b>unused</b>
17-16	BMASK	<b>Byte mask</b> Used as byte mask values for pattern match template data.
15-0	RFDATA	<b>Receive Filter Data</b>

## 4.0 Register Set (Continued)

### 4.2.19 Receive Filter Logic

The Receive Filter Logic supports a variety of techniques for qualifying incoming packets. The most basic filtering options include Accept All Broadcast, Accept All Multicast and Accept All Unicast packets. These options are enabled by setting the corresponding bit in the Receive Filter Control Register, RFCR. Accept on Perfect Match, Accept on Pattern Match, Accept on Multicast Hash and Accept on Unicast Hash are more robust in their filtering capabilities, but require additional programming of the Receive Filter registers and the internal filter RAM.

#### Accept on Perfect Match

When enabled, the Perfect Match Register is used to compare against the DA for packet acceptance. The Perfect Match Register is a 6-byte register accessed indirectly through the RFCR. The address of the internal receive filter register to be accessed is programmed through bits 8:0 of the RFCR. The Receive Filter Data Register, RFDR, is used for reading/writing the actual data.

RX Filter Address: 000h - Perfect Match octets 1-0  
002h - Perfect Match octets 3-2  
004h - Perfect Match octets 5-4

Octet 0 of the Perfect Match Register corresponds to the first octet of the packet as it appears on the wire. Octet 5 corresponds to the last octet of the DA as it appears on the wire.

The following steps are required to program the RFCR to accept packets on a perfect match of the DA.

**Example:** Destination Address of 08-00-17-07-28-55

```
iow | $RFCR (0000)   perfect match register, octets 1-0
iow | $RFDR (0008)   write address, octets 1-0
iow | $RFCR (0002)   perfect match register, octets 3-2
iow | $RFDR (0717)   write address, octets 3-2
iow | $RFCR (0004)   perfect match register, octets 5-4
iow | $RFDR (5528)   write address, octets 5-4
iow | $RFDR
($RFEN|$APM)       enable filtering, perfect match
```

#### Accept on Pattern Match

The Receive Filter Logic provides access to 4 separate internal RAM-based pattern buffers to be used as additional perfect match address registers. Pattern buffers 0 and 1 are 64 bytes deep, allowing perfect match on the first 64 bytes of a packet, and pattern buffers 2 and 3 are 128 bytes deep, allowing perfect match on the first 128 bytes of a packet.

When one or more of the Pattern Match enable bits are set in the RFCR, a packet will be accepted if it matches the associated pattern buffer. As indicated above, the pattern buffers are 64 and 128 bytes deep organized as 32 or 64 words, where a word is 18 bits. Bits 17 and 18 of a respective word are mask bits for byte 0 and byte 1 of the 16-bit data word (bits 15:0). An incoming packet is compared to each enabled pattern buffer on a byte by byte basis for a specified count. Masking a pattern byte results in a byte match regardless of its value (a don't care). A count value must be programmed for each pattern buffer to be used for comparison. The minimum valid count is 2 (2 bytes) and the maximum valid count is 32 for pattern buffers 0 and 1, and 64 for pattern buffers 2 and 3. The pattern count registers are internal receive filter registers accessed through the RFCR and the RFDR. The Receive Filter memory is also accessed through the RFCR and the RFDR. A memory map of the internal pattern RAM is shown in Figure 4-1.

4.0 Register Set (Continued)

	Byte1 Mask Bit	Byte0 Mask Bit	byte1	byte0	
Pattern3Word7F			byte1	byte0	3FE
Pattern2Word7F			byte1	byte0	3FC
Pattern3Word7E			byte1	byte0	3FA
Pattern2Word7E			byte1	byte0	3F8
⋮					⋮
Pattern3Word1			byte1	byte0	306
Pattern2Word1			byte1	byte0	304
Pattern3Word0			byte1	byte0	302
Pattern2Word0			byte1	byte0	300
Pattern1Word3F			byte1	byte0	2FE
Pattern0Word3F			byte1	byte0	2FC
Pattern1Word3E			byte1	byte0	2FA
Pattern0Word3E			byte1	byte0	2F8
⋮					⋮
Pattern1Word1			byte1	byte0	286
Pattern0Word1			byte1	byte0	284
Pattern1Word0			byte1	byte0	282
Pattern0Word0			byte1	byte0	280
Bit#	17	16	15	8 7	0

Figure 4-1 Pattern Buffer Memory - 180h words (word = 18bits)

## 4.0 Register Set (Continued)

**Example:** Pattern match on the following destination addresses:

```
02-00-03-01-04-02
12-10-13-11-14-12
22-20-23-21-24-22
32-30-33-31-34-32
```

```
set $PATBUF01 = 280
set $PATBUF23 = 300
```

# write counts

```
iow | $RFCR (0006)           # pattern count registers 1, 0
iow | $RFDR (0406)           # count 1 = 4, count 0 = 6
iow | $RFCR (0008)           # pattern count registers 3, 2
iow | $RFDR (0406)           # count 3 = 4, count 2 = 6
```

# write data pattern into buffer 0

```
iow | $RFCR ($PATBUF01)
iow | $RFDR (0002)
iow | $RFCR ($PATBUF01 + 4)
iow | $RFDR (0103)
iow | $RFCR ($PATBUF01 + 8)
iow | $RFDR (0204)
```

# write data pattern into buffer 1

```
iow | $RFCR ($PATBUF01 + 2)
iow | $RFDR (1012)
iow | $RFCR ($PATBUF01 + 6)
iow | $RFDR (1113)
iow | $RFCR ($PATBUF01 + a)
iow | $RFDR (1214)
```

# write data pattern into buffer 2

```
iow | $RFCR ($PATBUF23)
iow | $RFDR (2022)
iow | $RFCR ($PATBUF23 + 4)
iow | $RFDR (2123)
iow | $RFCR ($PATBUF23 + 8)
iow | $RFDR (2224)
```

# write data pattern into buffer 3

```
iow | $RFCR ($PATBUF23 + 2)
iow | $RFDR (3032)
iow | $RFCR ($PATBUF23 + 6)
iow | $RFDR (3133)
iow | $RFCR ($PATBUF23 + a)
iow | $RFDR (3234)
```

#enable receive filter on all patterns

```
iow | $RFCR ($RFEN|$APAT0|$APAT1|$APAT2|$APAT3)
```

**Example** of how to mask out a byte in a pattern:

# write data pattern into buffer 0

```
iow | $RFCR ($PATBUF01)
iow | $RFDR (10002)           #mask byte 0 (value = 02)
iow | $RFCR ($PATBUF01 + 4)
iow | $RFDR (20103)           #mask byte 1 (value = 01)
iow | $RFCR ($PATBUF01 + 8)
iow | $RFDR (30204)           #mask byte 0 and 1
```

## 4.0 Register Set (Continued)

### Accept on Multicast or Unicast Hash

Multicast and Unicast addresses may be further qualified by use of the receive filter hash functions. An internal 512 bit (64 byte) RAM-based hash table is used to perform imperfect filtering of multicast or unicast packets. By enabling either Multicast Hashing or Unicast Hashing in the RFCR, the receive filter logic will use the 9 least significant bits of the destination addresses' CRC as an index into the

Hash Table memory. The upper 4 bits represent the word address and the lower 5 bits select the bit within the word. If the corresponding bit is set, then the packet is accepted, otherwise the packet is rejected. The hash table memory is accessed through the RFCR and the RFDR. Refer to Figure 4-2 for a memory map. Below is example code for setting/clearing a bit in the hash table.

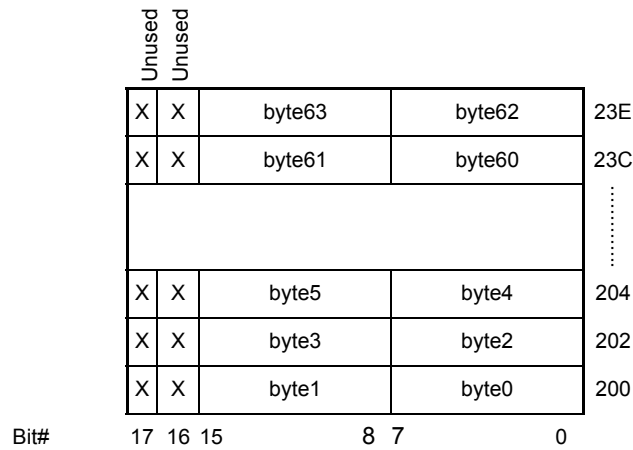

Figure 4-2 Hash Table Memory - 40h bytes addressed on word boundaries

```
set HASH_TABLE = 200
```

```
crc $DA # compute the CRC of the destination address
set index = ($crc >> 3)
set bit = ($crc & 01f) # lower 5 bits select which bit in 32 bit word
```

```
# write word address into RFCR
iow | $RFCR ($HASH_TABLE + $index)
```

```
# select bit to set/clear
if ($bit > f) set bit = ($bit - 010h) # use 16 bit register interface into 32bit RAM
set hash_bit = (0001 << $bit)
```

```
# read indexed word from table
ior | $RFDR
if ($SetBit) then
    set hash_word = ($rc | $hash_bit)
    iow | $RFDR ($hash_word)
else
    set hash_bit = (~$hash_bit)
    set hash_word = ($rc & $hash_bit)
    iow | $RFDR ($hash_word)
endif
```

```
iow | $RFCR ($RFEN|$MHEN|$UHEN)# enable multicast and/or unicast
# address hashing
```

## 4.0 Register Set (Continued)

### 4.2.20 Boot ROM Address Register

The BRAR is used to setup the address for an access to an external ROM/FLASH device.

Tag: BRAR                                      Size: 32 bits                                      Hard Reset: FFFFFFFFh  
 Offset: 0050h                                      Access: Read Write                                      Soft Reset: unchanged

Bit	Bit Name	Description
31	AUTOINC	<b>Auto-Increment</b> When set, the contents of ADDR will auto increment with every 32-bit access to the BRDR register.
30-16		<b>unused</b>
15-0	ADDR	<b>Boot ROM Address</b> 16-bit address used to access the external Boot ROM.

### 4.2.21 Boot ROM Data Register

The BRDR is used to read and write ROM/FLASH data from the data from/to an external ROM/FLASH device.

Tag: BRDR                                      Size: 32 bits                                      Hard Reset: undefined  
 Offset: 0054h                                      Access: Read Write                                      Soft Reset: undefined

Bit	Bit Name	Description
31-0	DATA	<b>Boot ROM Data</b> Access port to external Boot ROM. Software can use BRAR and BRDR to read (and write if FLASH memory is used) the external Boot ROM. All accesses must be 32-bits wide and aligned on 32-bit boundaries.

### 4.2.22 Silicon Revision Register

Tag: SRR                                      Size: 32 bits                                      Hard Reset: as defined  
 Offset: 0058h                                      Access: Read Only                                      Soft Reset: unchanged

Bit	Bit Name	Description
31-16		<b>unused</b> (reads return 0)
15-0	Rev	<b>Revision Level</b> SRR register value for the DP83816 silicon. DP83816AVNG      00000505h



## 4.0 Register Set (Continued)

### 4.2.23 Management Information Base Control Register

The MIBC register is used to control access to the statistics block and the warning bits and to control the collection of management information statistics.

Tag: MIBC                      Size: 32 bits                      Hard Reset: 00000002h  
 Offset: 005ch                      Access: Read Write                      Soft Reset: 00000002h

Bit	Bit Name	Description
31-4		<b>unused</b>
3	MIBS	<b>MIB Counter Strobe</b> Writing a 1 to this bit location causes the counters in all enabled blocks to increment by 1, providing a single-step test function. The MIBS bit is always read back as 0. <b>This bit is used for test purposes only and should be set to 0 for normal counter operation.</b>
2	ACLR	<b>Clear all counters</b> When set to a 1, this bit forces all counters to be reset to 0. This bit is always read back as 0.
1	FRZ	<b>Freeze all counters</b> When set to a 1, this bit forces count values to be frozen such that a read of the statistic block will represent management statistics at a given instant in time. When set to 0, the counters will increment normally and may be read individually while counting. While frozen events will not be recorded.
0	WRN	<b>Warning Test Indicator</b> This field is read only. This bit is set to 1 when statistic counters have reached their respective overflow warning condition. WRN will be cleared after one or more of the statistic counters have been cleared.

## 4.0 Register Set (Continued)

### 4.2.24 Management Information Base Registers

The counters provide a set of statistics compliant with the following management specifications: MIB II, Ether-like MIB, and IEEE MIB. The values provided are accessed through the various registers as shown below. All MIB counters are cleared to 0 when read.

Due to cost and space limitations, the counter bit widths provided in the DP83816 MIB are less than the bit widths called for in the above specifications. It is assumed that management agent software will maintain a set of fully compliant statistic values ("software" counters), utilizing the hardware counters to reduce the frequency at which these

"software" counters must be updated. Sizes for specific hardware statistic counters were chosen such that the count values will not roll over in less than 15 ms if incremented at the theoretical maximum rates described in the above specifications. However, given that the theoretical maximum counter rates do not represent realistic network traffic and events, the actual rollover rates for the hardware counters are more likely to be on the order of several seconds. The hardware counters are updated automatically by the MAC on the occurrence of each event.

**Table 4-3 MIB Registers**

Offset	Tag	Size	warning (MS bits)	Description
0060h	RXErroredPkts	16	8	Packets received with errors. This counter is incremented for each packet received with errors. This count includes packets which are automatically rejected from the FIFO due to both wire errors and FIFO overruns.
0064h	RXFCSErrors	8	4	Packets received with frame check sequence errors. This counter is incremented for each packet received with a Frame Check Sequence error (bad CRC). <b>Note:</b> For the MII interface, an FCS error is defined as a resulting invalid CRC after CRS goes invalid and an even number of bytes have been received.
0068h	RXMsdPktErrors	8	4	Packets missed due to FIFO overruns. This counter is incremented for each receive aborted due to data or status FIFO overruns (insufficient buffer space).
006Ch	RXFAErrors	8	4	Packets received with frame alignment errors. This counter is incremented for each packet received with a Frame Check Sequence error (bad CRC). <b>Note:</b> For the MII interface, an FAE error is defined as a resulting invalid CRC on the last full octet, and an odd number of nibbles have been received (Dribble nibble condition with a bad CRC).
0070h	RXSymbolErrors	8	4	Packets received with one or more symbol errors. This counter is incremented for each packet received with one or more symbol errors detected. <b>Note:</b> For the MII interface, a symbol error is indicated by the RXER signal becoming active for one or more clocks while the RXDV signal is active (during valid data reception).
0074h	RXFrameTooLong	4	2	Packets received with length greater than 1518 bytes (too long packets). This counter is incremented for each packet received with greater than the 802.3 standard maximum length of 1518 bytes.
0078h	TXSQEErrors	4	2	Loss of collision heartbeat during transmission. This counter is incremented when the collision heartbeat pulse is not detected by the PMD after a transmission.



## 4.0 Register Set (Continued)

Bit	Bit Name	Description
7	Collision Test	<b>Collision Test:</b> Default: 0 1 = Collision test enabled 0 = Normal operation When set, this bit will cause the COL signal to be asserted in response to the assertion of TXEN within 512-bit times. The COL signal will be de-asserted within 4-bit times in response to the de-assertion of TXEN.
6:0	Reserved	<b>Reserved:</b> Default: 0, RO

### 4.3.2 Basic Mode Status Register

Tag: BMSR                                      Size: 16 bits                                      Hard Reset: 7849h  
 Offset: 0084h                                      Access: Read Only

Bit	Bit Name	Description
15	100BASE-T4	<b>100BASE-T4 Capable:</b> Default: 0 0 = Device not able to perform 100BASE-T4 mode.
14	100BASE-TX Full Duplex	<b>100BASE-TX Full Duplex Capable:</b> Default: 1 1 = Device able to perform 100BASE-TX in full duplex mode
13	100BASE-TX Half Duplex	<b>100BASE-TX Half Duplex Capable:</b> Default: 1 1 = Device able to perform 100BASE-TX in half duplex mode.
12	10BASE-T Full Duplex	<b>10BASE-T Full Duplex Capable:</b> Default: 1 1 = Device able to perform 10BASE-T in full duplex mode
11	10BASE-T Half Duplex	<b>10BASE-T Half Duplex Capable:</b> Default: 1 1 = Device able to perform 10BASE-T in half duplex mode
10:7	Reserved	<b>Reserved:</b> Write as 0, read as 0
6	Preamble Suppression	<b>Preamble suppression Capable:</b> Default: 1 1 = Device able to perform management transaction with preamble suppressed, 32-bits of preamble needed only once after reset, invalid opcode or invalid turnaround. 0 = Normal management operation
5	Auto-Negotiation Complete	<b>Auto-Negotiation Complete:</b> Default: 0 1 = Auto-Negotiation process complete 0 = Auto-Negotiation process not complete
4	Remote Fault	<b>Remote Fault:</b> Default: 0/L(H) 1 = Remote Fault condition detected (cleared on read or by reset). Fault criteria: Far End Fault Indication or notification from Link Partner of Remote Fault. 0 = No remote fault condition detected
3	Auto-Negotiation Ability	<b>Auto Configuration Ability:</b> Default: 1 1 = Device is able to perform Auto-Negotiation 0 = Device is not able to perform Auto-Negotiation
2	Link Status	<b>Link Status:</b> Default: 0/L(L) 1 = Valid link established (for either 10 or 100 Mb/s operation) 0 = Link not established The criteria for link validity is implementation specific. The occurrence of a link failure condition will cause the Link Status bit to clear. Once cleared, this bit may only be set by establishing a good link condition and a read via the management interface.
1	Jabber Detect	<b>Jabber Detect:</b> Default: 0/LH 1 = Jabber condition detected 0 = No Jabber This bit is implemented with a latching function, such that the occurrence of a jabber condition causes it to set until it is cleared by a read to this register by the management interface or by a reset. This bit only has meaning in 10 Mb/s mode.
0	Extended Capability	<b>Extended Capability:</b> Default: 1 1 = Extended register capabilities 0 = Basic register set capabilities only

## 4.0 Register Set (Continued)

### 4.3.3 PHY Identifier Register #1

The PHY Identifier Registers #1 and #2 together form a unique identifier for the PHY section of this device. The Identifier consists of a concatenation of the Organizationally Unique Identifier (OUI), the vendor's model number and the model revision number. A PHY may return a value of zero in each of the 32 bits of the PHY Identifier if desired. The PHY Identifier is intended to support network management. National Semiconductor's IEEE assigned OUI is 080017h.

*Tag:* PHYIDR1                      *Size:* 16 bits                      *Hard Reset:* 2000h  
*Offset:* 0088h                      *Access:* Read Only

Bit	Bit Name	Description
15:0	OUI_MSB	<b>OUI Most Significant Bits:</b> Default: <0010 0000 0000 0000> Bits 3 to 18 of the OUI (080017h) are stored in bits 15 to 0 of this register. The most significant two bits of the OUI are ignored (the IEEE standard refers to these as bits 1 and 2).

### 4.3.4 PHY Identifier Register #2

*Tag:* PHYIDR2                      *Size:* 16 bits                      *Hard Reset:* 5C21h  
*Offset:* 008Ch                      *Access:* Read Only

Bit	Bit Name	Description
15:10	OUI_LSB	<b>OUI Least Significant Bits:</b> Default: <01 0111> Bits 19 to 24 of the OUI (080017h) are mapped to bits 15 to 10 of this register respectively.
9:4	VNDR_MDL	<b>Vendor Model Number:</b> Default: <00 0010> The six bits of vendor model number are mapped to bits 9 to 4 (most significant bit to bit 9).
3:0	MDL_REV	<b>Model Revision Number:</b> Default: <0001> Four bits of the vendor model revision number are mapped to bits 3 to 0 (most significant bit to bit 3). This field will be incremented for all major device changes.

### 4.3.5 Auto-Negotiation Advertisement Register

This register contains the advertised abilities of this device as they will be transmitted to its link partner during Auto-Negotiation.

*Tag:* ANAR                              *Size:* 16 bits                      *Hard Reset:* 05E1h  
*Offset:* 0090h                      *Access:* Read Write

Bit	Bit Name	Description
15	NP	<b>Next Page Indication:</b> Default: 0 0 = Next Page Transfer not desired 1 = Next Page Transfer desired
14	Reserved	<b>Reserved by IEEE:</b> Writes ignored, Read as 0
13	RF	<b>Remote Fault:</b> Default: 0 1 = Advertises that this device has detected a Remote Fault 0 = No Remote Fault detected
12:11	Reserved	<b>Reserved for Future IEEE use:</b> Write as 0, Read as 0
10	PAUSE	<b>PAUSE:</b> Default: dependent on the setting of the PAUSE_ADV in the CFG register 1 = Advertise that the DTE (MAC) has implemented both the optional MAC control sublayer and the pause function as specified in clause 31 and annex 31B of 802.3u. 0 = No MAC based full duplex flow control

## 4.0 Register Set (Continued)

Bit	Bit Name	Description
9	T4	<b>100BASE-T4 Support:</b> Default: 0/ RO 1 = 100BASE-T4 is supported by the local device 0 = 100BASE-T4 not supported
8	TX_FD	<b>100BASE-TX Full Duplex Support:</b> Default: dependent on setting of the ANEG_SEL in the CFG register 1 = 100BASE-TX Full Duplex is supported by the local device 0 = 100BASE-TX Full Duplex not supported
7	TX	<b>100BASE-TX Support:</b> Default: dependent on the setting of the ANEG_SEL bits in the CFG register 1 = 100BASE-TX is supported by the local device 0 = 100BASE-TX not supported
6	10_FD	<b>10BASE-T Full Duplex Support:</b> Default: dependent on setting of the ANEG_SEL in the CFG register 1 = 10BASE-T Full Duplex is supported by the local device 0 = 10BASE-T Full Duplex not supported
5	10	<b>10BASE-T Support:</b> Default: dependent on the setting of the ANEG_SEL bits in the CFG register 1 = 10BASE-T is supported by the local device 0 = 10BASE-T not supported
4:0	Selector	<b>Protocol Selection Bits:</b> Default: <00001> These bits contain the binary encoded protocol selector supported by this port. <00001> indicates that this device supports IEEE 802.3u.

### 4.3.6 Auto-Negotiation Link Partner Ability Register

This register contains the advertised abilities of the Link Partner as received during Auto-Negotiation. The content changes after the successful auto-negotiation if Next-pages are supported.

Tag: ANLPAR                      Size: 16 bits                      Hard Reset: 0000h  
Offset: 0094h                      Access: Read Only

Bit	Bit Name	Description
15	NP	<b>Next Page Indication:</b> 0 = Link Partner does not desire Next Page Transfer 1 = Link Partner desires Next Page Transfer
14	ACK	<b>Acknowledge:</b> 1 = Link Partner acknowledges reception of the ability data word 0 = Not acknowledged The Device's Auto-Negotiation state machine will automatically control this bit based on the incoming FLP bursts.
13	RF	<b>Remote Fault:</b> 1 = Remote Fault indicated by Link Partner 0 = No Remote Fault indicated by Link Partner
12:10	Reserved	<b>Reserved for Future IEEE use:</b> Write as 0, read as 0
9	T4	<b>100BASE-T4 Support:</b> 1 = 100BASE-T4 is supported by the Link Partner 0 = 100BASE-T4 not supported by the Link Partner
8	TX_FD	<b>100BASE-TX Full Duplex Support:</b> 1 = 100BASE-TX Full Duplex is supported by the Link Partner 0 = 100BASE-TX Full Duplex not supported by the Link Partner
7	TX	<b>100BASE-TX Support:</b> 1 = 100BASE-TX is supported by the Link Partner 0 = 100BASE-TX not supported by the Link Partner
6	10_FD	<b>10BASE-T Full Duplex Support:</b> 1 = 10BASE-T Full Duplex is supported by the Link Partner 0 = 10BASE-T Full Duplex not supported by the Link Partner

## 4.0 Register Set (Continued)

Bit	Bit Name	Description
5	10	<b>10BASE-T Support:</b> 1 = 10BASE-T is supported by the Link Partner 0 = 10BASE-T not supported by the Link Partner
4:0	Selector	<b>Protocol Selection Bits:</b> Link Partners's binary encoded protocol selector.

### 4.3.7 Auto-Negotiate Expansion Register

This register contains additional Local Device and Link Partner status information.

Tag: ANER                      Size: 16 bits                      Hard Reset: 0004h  
Offset: 0098h                      Access: Read Only

Bit	Bit Name	Description
15:5	Reserved	<b>Reserved:</b> Writes ignored, Read as 0.
4	PDF	<b>Parallel Detection Fault:</b> 1 = A fault has been detected via the Parallel Detection function 0 = A fault has not been detected
3	LP_NP_ABLE	<b>Link Partner Next Page Able:</b> 1 = Link Partner does support Next Page 0 = Link Partner does not support Next Page
2	NP_ABLE	<b>Next Page Able:</b> 1 = Indicates local device is able to send additional "Next Pages"
1	PAGE_RX	<b>Link Code Word Page Received: RO/COR</b> 1 = Link Code Word has been received, cleared on a read 0 = Link Code Word has not been received
0	LP_AN_ABLE	<b>Link Partner Auto-Negotiation Able:</b> 1 = Indicates that the Link Partner supports Auto-Negotiation 0 = Indicates that the Link Partner does not support Auto-Negotiation

### 4.3.8 Auto-Negotiation Next Page Transmit Register

This register contains the next page information sent by this device to its Link Partner during Auto-Negotiation.

Tag: ANNPTR                      Size: 16 bits                      Hard Reset: 2001h  
Offset: 009Ch                      Access: Read Write

Bit	Bit Name	Description
15	NP	<b>Next Page Indication:</b> Default: 0 0 = No other Next Page Transfer desired 1 = Another Next Page desired
14	Reserved	<b>Reserved:</b> Writes ignored, read as 0
13	MP	<b>Message Page:</b> Default: 1 1 = Message Page 0 = Unformatted Page

## 4.0 Register Set (Continued)

Bit	Bit Name	Description
12	ACK2	<b>Acknowledge2:</b> Default: 0 1 = Will comply with message 0 = Cannot comply with message Acknowledge2 is used by the next page function to indicate that Local Device has the ability to comply with the message received.
11	TOG_TX	<b>Toggle:</b> Default: 0, RO 1 = Value of toggle bit in previously transmitted Link Code Word was 0 0 = Value of toggle bit in previously transmitted Link Code Word was 1 Toggle is used by the Arbitration function within Auto-Negotiation to ensure synchronization with the Link Partner during Next Page exchange. This bit shall always take the opposite value of the Toggle bit in the previously exchanged Link Code Word.
10:0	CODE	<b>Code Field:</b> Default: <000 0000 0001> This field represents the code field of the next page transmission. If the MP bit is set (bit 13 of this register), then the code shall be interpreted as a "Message Page", as defined in annex 28C of IEEE 802.3u. Otherwise, the code shall be interpreted as an "Un-formatted Page", and the interpretation is application specific. The default value of the CODE represents a Null Page as defined in Annex 28C of IEEE 802.3u.

### 4.3.9 PHY Status Register

This register provides a single location within the register set for quick access to commonly accessed information.

*Tag:* PHYSTS                      *Size:* 16 bits                      *Hard Reset:* 0000h  
*Offset:* 00C0h                      *Access:* Read Only

Bit	Bit Name	Description
15:14	Reserved	<b>Reserved:</b> Write ignored, read as 0.
13	Receive Error Latch	<b>Receive Error Latch:</b> This bit will be cleared upon a read of the RECR register. 1 = Receive error event has occurred since last read of RXERCNT (address 0xD4) 0 = No receive error event has occurred
12	Polarity Status	<b>Polarity Status:</b> This bit is a duplication of bit 4 in the TBTSR register. This bit will be cleared upon a read of the TBTSR register, but not upon a read of the PHYSTS register. 1 = Inverted Polarity detected 0 = Correct Polarity detected
11	False Carrier Sense Latch	<b>False Carrier Sense Latch:</b> Default: 0, RO/LH This bit will be cleared upon a read of the FCSCR register. 1 = False Carrier event has occurred since last read of FCSCR (address 0xD0) 0 = No False Carrier event has occurred
10	Signal Detect	<b>Signal Detect:</b> Default: 0, RO/LL 100BASE-TX unconditional Signal Detect from PMD.
9	De-scrambler Lock	<b>De-scrambler Lock:</b> Default: 0, RO/LL 100BASE-TX De-scrambler Lock from PMD.
8	Page Received	<b>Link Code Word Page Received:</b> This is a duplicate of the Page Received bit in the ANER register, but this bit will not be cleared upon a read of the PHYSTS register. 1 = A new Link Code Word Page has been received. Cleared on read of the ANER (address 0x98, bit 1) 0 = Link Code Word Page has not been received
7	MII Interrupt	<b>MII Interrupt Pending:</b> Default: 0, RO/LH 1 = Indicates that an internal interrupt is pending, cleared by the current read 0 = No interrupt pending



## 4.0 Register Set (Continued)

Bit	Bit Name	Description
6	Remote Fault	<p><b>Remote Fault:</b>            1 = Remote Fault condition detected (cleared on read of BMSR (address 0x84) register or by reset). Fault criteria: notification from Link Partner of Remote Fault via Auto-Negotiation            0 = No remote fault condition detected</p>
5	Jabber Detect	<p><b>Jabber Detect:</b> This bit only has meaning in 10 Mb/s mode            This bit is a duplicate of the Jabber Detect bit in the BMSR register, except that it is not cleared upon a read of the PHYSTS register.            1 = Jabber condition detected            0 = No Jabber</p>
4	Auto-Neg. Complete	<p><b>Auto-Negotiation Complete:</b>            1 = Auto-Negotiation complete            0 = Auto-Negotiation not complete</p>
3	Loopback Status	<p><b>Loopback:</b>            1 = Loopback enabled            0 = Normal operation</p>
2	Duplex Status	<p><b>Duplex:</b>            This bit indicates duplex status and is determined from Auto-Negotiation or Forced Modes.            1 = Full duplex mode            0 = Half duplex mode  <b>Note:</b> This bit is only valid if Auto-Negotiation is enabled and complete and there is a valid link or if Auto-Negotiation is disabled and there is a valid link.</p>
1	Speed Status	<p><b>Speed10:</b>            This bit indicates the status of the speed and is determined from Auto-Negotiation or Forced Modes.            1 = 10 Mb/s mode            0 = 100 Mb/s mode  <b>Note:</b> This bit is only valid if Auto-Negotiation is enabled and complete and there is a valid link or if Auto-Negotiation is disabled and there is a valid link.</p>
0	Link Status	<p><b>Link Status:</b>            This bit is a duplicate of the Link Status bit in the BMSR register, except that it will not be cleared upon a read of the PHYSTS register.            1 = Valid link established (for either 10 or 100 Mb/s operation)            0 = Link not established</p>

## 4.0 Register Set (Continued)

### 4.3.10 MII Interrupt Control Register

This register implements the MII Interrupt PHY Specific Control register. Sources for interrupt generation include: Link State Change, Jabber Event, Remote Fault, Auto-Negotiation Complete or any of the counters becoming half-full. Note that the TINT bit operates independently of the INTEN bit. In other words, INTEN does not need to be active to generate the test interrupt.

Tag: MICR                                      Size: 16 bits                                      Hard Reset: 0000h  
Offset: 00C4h                                      Access: Read Write

Bit	Bit Name	Description
15:2	Reserved	<b>Reserved:</b> Writes ignored, Read as 0
1	INTEN	<b>Interrupt Enable:</b> 1 = Enable event based interrupts 0 = Disable event based interrupts
0	TINT	<b>Test Interrupt:</b> Forces the PHY to generate an interrupt at the end of each management read to facilitate interrupt testing. 1 = Generate an interrupt 0 = Do not generate interrupt

### 4.3.11 MII Interrupt Status and Misc. Control Register

This register implements the MII Interrupt PHY Control and Status information. These Interrupts are PHY based events. When any of these events occur and its respective bit is not masked, and MICR:INTEN is enabled, the interrupt will be signalled in ISR:PHY.

Tag: MISR                                      Size: 16 bits                                      Hard Reset: 0000h  
Offset: 00C8h                                      Access: Read Write

Bit	Bit Name	Description
15	MINT	<b>MII Interrupt Pending:</b> Default: 0, RO/COR 1 = Indicates that an interrupt is pending and is cleared by the current read. 0 = no interrupt pending
14	MSK_LINK	<b>Mask Link:</b> When this bit is 0, the change of link status event will cause the interrupt to be seen by the ISR.
13	MSK_JAB	<b>Mask Jabber:</b> When this bit is 0, the Jabber event will cause the interrupt to be seen by the ISR.
12	MSK_RF	<b>Mask Remote Fault:</b> When this bit is 0, the Remote Fault event will cause the interrupt to be seen by the ISR.
11	MSK_ANC	<b>Mask Auto-Neg. Complete:</b> When this bit is 0, the Auto-negotiation complete event will cause the interrupt to be seen by the ISR.
10	MSK_FHF	<b>Mask False Carrier Half Full:</b> When this bit is 0, the False Carrier Counter Register half-full event will cause the interrupt to be seen by the ISR.
9	MSK_RHF	<b>Mask Rx Error Half Full:</b> When this bit is 0, the Receive Error Counter Register half-full event will cause the interrupt to be seen by the ISR.
8:0	Reserved	<b>Reserved:</b> Writes ignored, Read as 0

## 4.0 Register Set (Continued)

### 4.3.12 False Carrier Sense Counter Register

This counter provides information required to implement the “FalseCarriers” attribute within the MAU managed object class of Clause 30 of the IEEE 802.3u specification.

*Tag:* FCSCR                      *Size:* 16 bits                      *Hard Reset:* 0000h  
*Offset:* 00D0h                      *Access:* Read Write

Bit	Bit Name	Description
15:8	Reserved	<b>Reserved:</b> Writes ignored, Read as 0
7:0	FCSCNT[7:0]	<b>False Carrier Event Counter:</b> Default: 0, RW/COR This 8-bit counter increments on every false carrier event. This counter sticks when it reaches its max count (FFh).

### 4.3.13 Receiver Error Counter Register

This counter provides information required to implement the “SymbolErrorDuringCarrier” attribute within the PHY managed object class of Clause 30 of the IEEE 802.3u specification.

*Tag:* RECR                      *Size:* 16 bits                      *Hard Reset:* 0000h  
*Offset:* 00D4h                      *Access:* Read Write

Bit	Bit Name	Description
15:8	Reserved	<b>Reserved:</b> Writes ignored, Read as 0
7:0	RXERCNT[7:0]	<b>RXER Counter:</b> Default: 0, RW / COR This 8-bit counter increments for each receive error detected. when a valid carrier is present and there is at least one occurrence of an invalid data symbol. This event can increment only once per valid carrier event. If a collision is present, the attribute will not increment. The counter sticks when it reaches its max count.

### 4.3.14 100 Mb/s PCS Configuration and Status Register

*Tag:* PCSR                      *Size:* 16 bits                      *Hard Reset:* 0100h  
*Offset:* 00D8h                      *Access:* Read Write

Bit	Bit Name	Description
15:13	Reserved	<b>Reserved:</b> Writes ignored, Read as 0
12	BYP_4B5B	<b>Bypass 4B/5B Encoding:</b> 1 = 4B5B encoder functions bypassed 0 = Normal 4B5B operation
11	FREE_CLK	<b>Receive Clock:</b> 1 = RX_CK is free-running 0 = RX_CK phase adjusted based on alignment
10	TQ_EN	<b>100 Mb/s True Quiet Mode Enable:</b> 1 = Transmit True Quiet Mode 0 = Normal Transmit Mode
9	SD_FORCE_B	<b>Signal Detect Force:</b> 1 = Forces Signal Detection 0 = Normal SD operation

## 4.0 Register Set (Continued)

Bit	Bit Name	Description
8	SD_OPTION	<b>Signal Detect Option:</b> 1 = Enhanced signal detect algorithm 0 = Reduced signal detect algorithm
7:6	Reserved	<b>Reserved:</b> Read as 0
5	FORCE_100_OK	<b>Force 100 Mb/s Good Link:</b> 1 = Forces 100 Mb/s Good Link 0 = Normal 100 Mb/s operation
4:3	Reserved	<b>Reserved:</b> Read as 0
2	NRZI_BYPASS	<b>NRZI Bypass Enable:</b> 1 = NRZI Bypass Enabled 0 = NRZI Bypass Disabled
1:0	Reserved	<b>Reserved:</b> Read as 0

### 4.3.15 PHY Control Register

Tag: PHYCR                      Size: 16 bits                      Hard Reset: 003Fh  
 Offset: 00E4h                      Access: Read Write

Bit	Bit Name	Description
15:12	Reserved	<b>Reserved</b>
11	PSR_15	<b>BIST Sequence select:</b> Selects length of LFSR used in BIST 1 = PSR15 selected 0 = PSR9 selected
10	BIST_STATUS	<b>BIST Test Status:</b> Default: 0, LL/RO 1 = BIST pass 0 = BIST fail. Latched, cleared by write to BIST start bit.
9	BIST_START	<b>BIST Start:</b> BIST runs continuously until stopped. Minimum time to run should be 1 ms. 1 = BIST start 0 = BIST stop
8	BP_STRETCH	<b>Bypass LED Stretching:</b> This will bypass the LED stretching and the LEDs will reflect the internal value. 1 = Bypass LED stretching 0 = Normal operation
7	PAUSE_STS	<b>Pause Compare Status:</b> Default: 0, RO 0 = Local Device and the Link Partner are not Pause capable 1 = Local Device and the Link Partner are both Pause capable
6:5	Reserved	<b>Reserved</b>
4:0	PHYADDR[4:0]	<b>PHY Address:</b> Default: <11111b>, RW PHY address for the port.

## 4.0 Register Set (Continued)

### 4.3.16 10BASE-T Status/Control Register

Tag: TBTSCR

Size: 16 bits

Hard Reset: 0804h

Offset: 00E8h

Access: Read Write

Bit	Bit Name	Description
15:9	Unused	
8	LOOPBACK_10_DIS	<b>10BASE-T Loopback Disable:</b> This bit is OR'ed with bit 14 (Loopback) in the BMCR. 1 = 10 Mb/s Loopback is enabled 0 = 10 Mb/s Loopback is disabled
7	LP_DIS	<b>Normal Link Pulse Disable:</b> 1 = Transmission of NLPs is disabled 0 = Transmission of NLPs is enabled
6	FORCE_LINK_10	<b>Force 10 Mb/s Good Link:</b> 1 = Forced Good 10 Mb/s Link 0 = Normal Link Status
5	FORCE_POL_COR	<b>Force 10 Mb/s Polarity Correction:</b> 1 = Force inverted polarity 0 = Normal polarity
4	POLARITY	<b>10 Mb/s Polarity Status: RO/LH</b> This bit is a duplication of bit 12 in the PHYSTS register. Both bits will be cleared upon a read of either register. 1 = Inverted Polarity detected 0 = Correct Polarity detected
3	AUTOPOL_DIS	<b>Auto Polarity Detection &amp; Correction Disable:</b> 1 = Polarity Sense & Correction disabled 0 = Polarity Sense & Correction enabled
2	Reserved	<b>Reserved</b> This bit must be written as a one.
1	HEARTBEAT_DIS	<b>Heartbeat Disable:</b> This bit only has influence in half-duplex 10 Mb/s mode. 1 = Heartbeat function disabled 0 = Heartbeat function enabled When the device is operating at 100 Mb/s or configured for full duplex, this bit will be ignored - the heartbeat function is disabled.
0	JABBER_DIS	<b>Jabber Disable:</b> Applicable only in 10BASE-T Full Duplex. 1 = Jabber function disabled 0 = Jabber function enabled

## 5.0 Buffer Management

The buffer management scheme used on the DP83816 allows quick, simple and efficient use of the frame buffer memory. Frames are saved in similar formats for both transmit and receive. The buffer management scheme also uses separate buffers and descriptors for packet information. This allows effective transfers of data from the receive buffer to the transmit buffer by simply transferring the descriptor from the receive queue to the transmit queue.

The format of the descriptors allows the packets to be saved in a number of configurations. A packet can be stored in memory with a single descriptor and a single packet fragment, or multiple descriptors each with a single fragment. This flexibility allows the user to configure the DP83816 to maximize efficiency. Architecture of the specific system's buffer memory, as well as the nature of network traffic, will determine the most suitable configuration of packet descriptors and fragments.

### 5.1 Overview

The buffer management design has the following goals:

- simplicity,
- efficient use of the PCI bus (the overhead of the buffer management technique is minimal),
- low CPU utilization,
- flexibility.

Descriptors may be either per-packet or per-packet-fragment. Each descriptor may describe one packet fragment. Receive and transmit descriptors are symmetrical.

#### 5.1.1 Descriptor Format

DP83816 uses a symmetrical format for transmit and receive descriptors. In bridging and switching applications this symmetry allows software to forward packets by simply moving the list of descriptors that describe a single received packet from the receive list of one MAC to the transmit list of another. Descriptors must be aligned on an even long word (32-bit) boundary.

**Table 5-1 DP83816 Descriptor Format**

Offset	Tag	Description
0000h	link	32-bit "link" field to the next descriptor in the linked list. Bits 1-0 must be 0, as descriptors must be aligned on 32-bit boundaries.
0004h	cmdsts	32-bit Command/Status Field (bit-encoded).
0008h	bufptr	32-bit pointer to the first fragment or buffer. In transmit descriptors, the buffer can begin on any byte boundary. In receive descriptors, the buffer must be aligned on a 32-bit boundary.

The original DP83810A Descriptor format supported multiple fragments per descriptor. DP83816 only supports a single fragment per descriptor. By default, DP83816 will use the descriptor format shown above. By setting CFG:EUPHCOMP, software may force compatibility with the previous DP83810A Descriptor format (although still

only single fragment descriptors are supported). When CFG:EUPHCOMP is set, then *bufptr* is at offset 0Ch, and the 32-bit *bufcnt* field at offset 08h is ignored.

Some of the bit definitions in the *cmdsts* field are common to both receive and transmit descriptors:

**Table 5-2 cmdsts Common Bit Definitions**

Bit	Tag	Description	Usage
31	OWN	Descriptor Ownership	Set to 1 by the <i>data producer</i> of the descriptor to transfer ownership to the <i>data consumer</i> of the descriptor. Set to 0 by the <i>data consumer</i> of the descriptor to return ownership to the <i>data producer</i> of the descriptor. For transmit descriptors, the driver is the <i>data producer</i> , and the DP83816 is the <i>data consumer</i> . For receive descriptors, the DP83816 is the <i>data producer</i> , and the driver is the <i>data consumer</i> .
30	MORE	More descriptors	Set to 1 to indicate that this is NOT the last descriptor in a packet (there are MORE to follow). When 0, this descriptor is the last descriptor in a packet. Completion status bits are only valid when this bit is zero.
29	INTR	Interrupt	Set to 1 by software to request a "descriptor interrupt" when DP83816 transfers the ownership of this descriptor back to software.
28	SUPCRC INCCRC	Suppress CRC / Include CRC	In transmit descriptors, this indicates that CRC should not be appended by the MAC. On receives, this bit is always set, as the CRC is always copied to the end of the buffer by the hardware.

## 5.0 Buffer Management (Continued)

27	OK	Packet OK	In the last descriptor in a packet, this bit indicates that the packet was either sent or received successfully.
26-16	---		The usage of these bits differ in receive and transmit descriptors. See below for details.
15-12			(reserved)
11-0	SIZE	Descriptor Byte Count	Set to the size in bytes of the data.

**Table 5-3 Transmit Status Bit Definitions**

Bit	Tag	Description	Usage
26	TXA	Transmit Abort	Transmission of this packet was aborted.
25	TFU	Transmit FIFO Underrun	Transmit FIFO was exhausted during the transmission of this packet.
24	CRS	Carrier Sense Lost	Carrier was lost during the transmission of this packet. This condition is not reported if TXCFG:CSI is set.
23	TD	Transmit Deferred	Transmission of this packet was deferred.
22	ED	Excessive Deferral	The length of deferral during the transmission of this packet was excessive (> 3.2 ms), indicating transmission failure.
21	OWC	Out of Window Collision	The MAC encountered an "out of window" collision during the transmission of this packet.
20	EC	Excessive Collisions	The number of collisions during the transmission of this packet was excessive, indicating transmission failure. If TXCFG register ECRETRY=0, this bit is set after 16 collisions. If TXCFG register ECRETRY=1, this bit is set after 4 Excessive Collision events (64 collisions).
19-16	CCNT	Collision Count	If TXCFG register ECRETRY=0, this field indicates the number of collisions encountered during the transmission of this packet. If TXCFG register ECRETRY=1, CCNT[3:2] = Excessive Collisions (0-3) CCNT[1] = Multiple Collisions CCNT[0] = Single Collision  Note that Excessive Collisions indicate 16 attempts failed, while multiple and single collisions indicate collisions in addition to any excessive collisions. For example a collision count of 33 includes 2 Excessive Collisions and will also set the Single Collision bit.

## 5.0 Buffer Management (Continued)

**Table 5-4 Receive Status Bit Definitions**

Bit	Tag	Description	Usage
26	RXA	Receive Aborted	Set to 1 by DP83816 when the receive was aborted, the value of this bit always equals RXO. Exists for backward compatibility.
25	RXO	Receive Overrun	Set to 1 by DP83816 to indicate that a receive overrun condition occurred. RXA will also be set.
24-23	DEST	Destination Class	<p>When the receive filter is enabled, these bits will indicate the destination address class as follows:</p> <ul style="list-style-type: none"> <li>00 - Packet was rejected</li> <li>01 - Destination is a Unicast address</li> <li>10 - Destination is a Multicast address</li> <li>11 - Destination is a Broadcast address</li> </ul> <p>If the Receive Filter is enabled, 00 indicates that the packet was rejected. Normally packets that are rejected do not cause any bus activity, nor do they consume receive descriptors. However, this condition could occur if the packet is rejected by the Receive Filter later in the packet than the receive drain threshold (RXCFG:DRTH).</p> <p><b>Note:</b> The DEST bits may not represent a correct DA class for runt packets received with less than 6 bytes.</p>
22	LONG	Too Long Packet Received	<p>If RXCFG:ALP=0, this flag indicates that the size of the receive packet exceeded 1518 bytes.</p> <p>If RXCFG:ALP=1, this flag indicates that the size of the receive packet exceeded 2046 bytes.</p>
21	RUNT	Runt Packet Received	The size of the receive packet was less than 64 bytes (inc. CRC).
20	ISE	Invalid Symbol Error	(100 Mb/s only) An invalid symbol was encountered during the reception of this packet.
19	CRCE	CRC Error	The CRC appended to the end of this packet was invalid.
18	FAE	Frame Alignment Error	The packet did not contain an integral number of octets.
17	LBP	Loopback Packet	The packet is the result of a loopback transmission.
16	COL	Collision Activity	The receive packet had a collision during reception.

### 5.1.2 Single Descriptor Packets

To represent a packet in a single descriptor, the MORE bit in the cmdsts field is set to 0.

single descriptor / single fragment

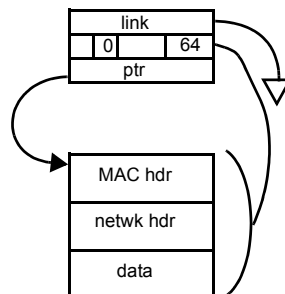

**Figure 5-1 Single Descriptor Packets**



## 5.0 Buffer Management (Continued)

### 5.1.3 Multiple Descriptor Packets

A single packet may also cross descriptor boundaries. This is indicated by setting the MORE bit in all descriptors except the last one in the packet. Ethernet applications (bridges, switches, routers, etc.) can optimize memory utilization by using a single small buffer per receive descriptor, and allowing the DP83816 hardware to use the minimum number of buffers necessary to store an incoming packet.

### 5.1.4 Descriptor Lists

Descriptors are organized in linked lists using the link field. The system designer may also choose to implement a "ring" of descriptors by linking the last descriptor in the list back to the first. A list of descriptors may represent any number of packets or packet fragments.

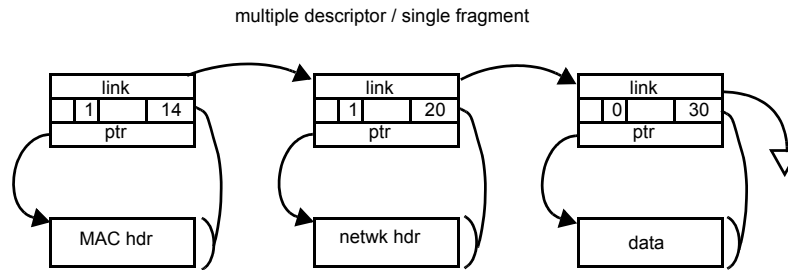

Figure 5-2 Multiple Descriptor Packets

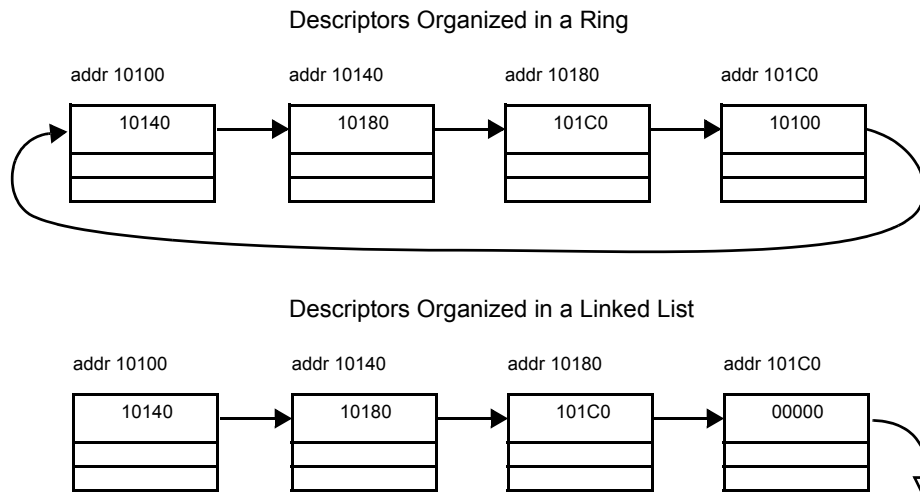
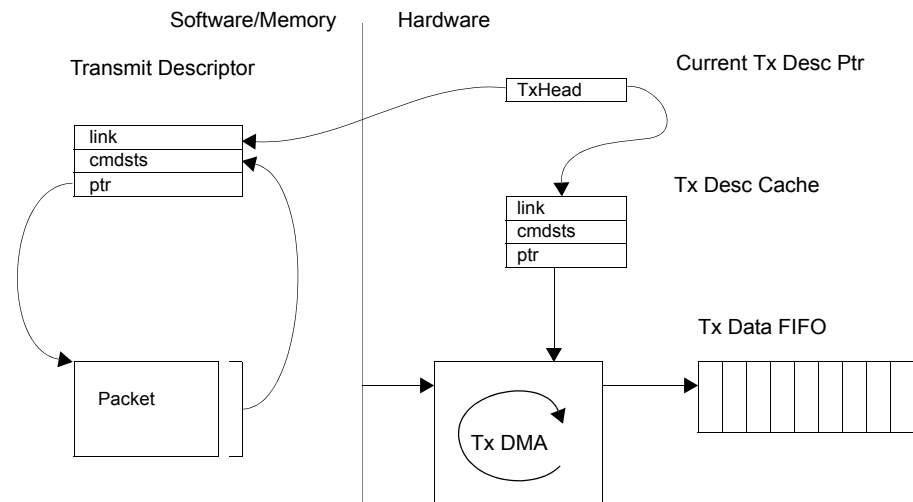

Figure 5-3 List and Ring Descriptor Organization

## 5.0 Buffer Management (Continued)

### 5.2 Transmit Architecture

The following figure illustrates the transmit architecture of the DP83816 10/100 Ethernet Controller.



**Figure 5-4 Transmit Architecture**

When the CR:TXE bit is set to 1 (regardless of the current state), and the DP83816 transmitter is idle, then DP83816 will read the contents of the current transmit descriptor into the TxDescCache. The DP83816's TxDescCache can hold a single fragment pointer/count combination.

#### 5.2.1 Transmit State Machine

The transmit state machine has the following states:

txIdle	The transmit state machine is idle.
txDescRefr	Waiting for the "refresh" transfer of the link field of a completed descriptor from the PCI bus.
txDescRead	Waiting for the transfer of a complete descriptor from the PCI bus into the TxDescriptorCache.
txFifoBlock	Waiting for free space in the TxDataFIFO to reach TxFillThreshold.
txFragRead	Waiting for the transfer of a fragment (or portion of a fragment) from the PCI bus to the TxDataFIFO.
txDescWrite	Waiting for the completion of the write of the cmdsts field of an intermediate transmit descriptor (cmdsts.MORE == 1) to host memory.
txAdvance	(transitory state) Examine the link field of the current descriptor and advance to the next descriptor if link is not NULL.

The transmit state machine manipulates the following internal data spaces:

TXDP	A 32-bit register that points to the current transmit descriptor.
CTDD	An internal bit flag that is set when the current transmit descriptor has been completed, and ownership has been returned to the driver. It is cleared whenever TXDP is loaded with a new value (either by the state machine, or the driver).
TxDescCache	An internal data space equal to the size of the maximum transmit descriptor supported.
descCnt	Count of bytes remaining in the current descriptor.
fragPtr	Pointer to the next unread byte in the current fragment.
txFifoCnt	Current amount of data in the txDataFifo in bytes.
txFifoAvail	Current amount of free space in the txDataFifo in bytes (size of the txDataFifo - txFifoCnt).

Inputs to the transmit state machine include the following events:

CR:TXE	Driver asserts the TXE bit in the command register (similar to SONIC).
XferDone	Completion of a PCI bus transfer request.
FifoAvail	TxFifoAvail is greater than TxFillThreshold.

## 5.0 Buffer Management (Continued)

Table 5-5 Transmit State Tables

State	Event	Next State	Actions
txIdle	CR:TXE && !CTDD	txDescRead	Start a burst transfer at address TXDP and a length derived from TXCFG.
	CR:TXE && CTDD	txDescRefr	Start a burst transfer to refresh the link field of the current descriptor.
txDescRefr	XferDone	txAdvance	
txDescRead	XferDone && OWN	txFIFOblock	
	XferDone && !OWN	txIdle	Set ISR:TXIDLE.
txFIFOblock	FifoAvail	txFragRead	Start a burst transfer into the TxDataFIFO from fragPtr. The length will be the minimum of txFifoAvail and descCnt. Decrement descCnt accordingly.
	(descCnt == 0) && MORE	txDescWrite	Start a burst transfer to write the status back to the descriptor, clearing the OWN bit.
	(descCnt == 0) && !MORE	txAdvance	Write the value of TXDP to the txDataFIFO as a handle.
txFragRead	XferDone	txFIFOblock	
txDescWrite	XferDone	txAdvance	
txAdvance	link != NULL	txDescRead	TXDP <- txDescCache.link. Clear CTDD. Start a burst transfer at address TXDP with a length derived from TXCFG.
	link == NULL	txIdle	Set CTDD. Set ISR:TXIDLE. Clear CR:TXE.

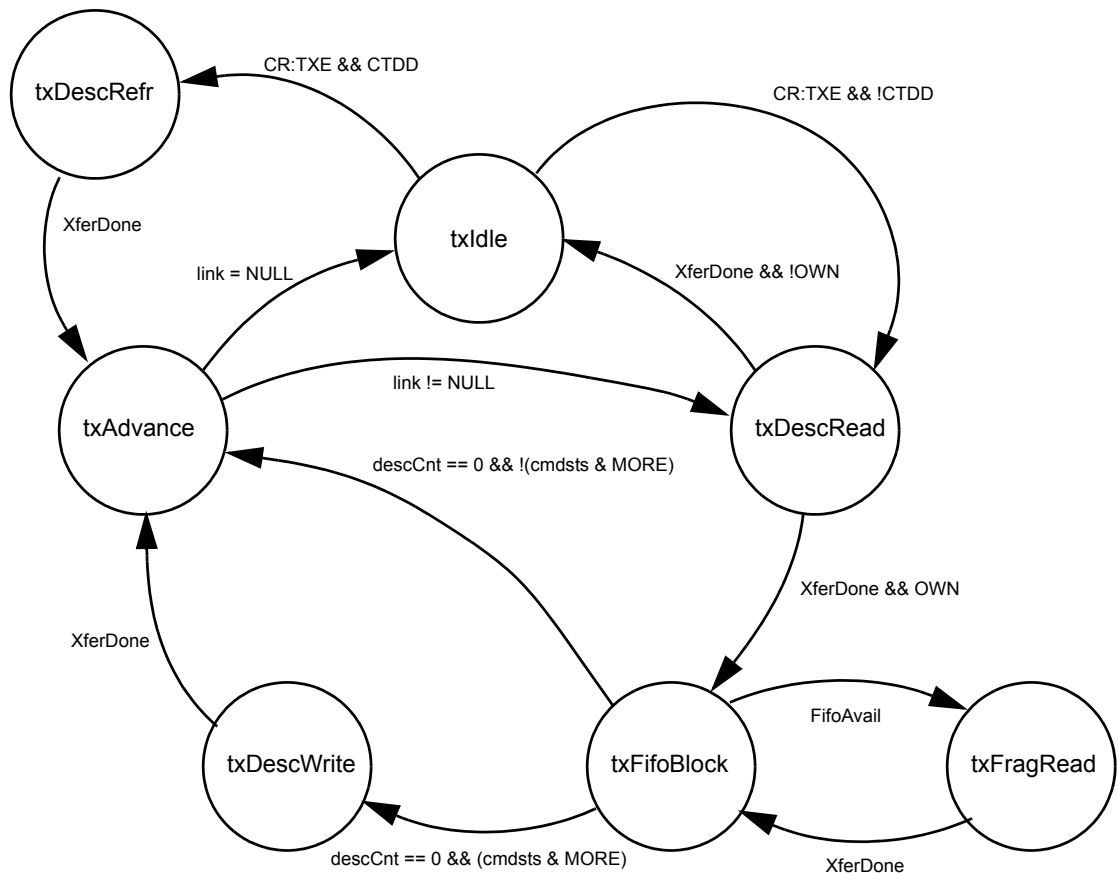

Figure 5-5 Transmit State Diagram

## 5.0 Buffer Management (Continued)

### 5.2.2 Transmit Data Flow

In the DP83816 transmit architecture, packet transmission involves the following steps:

1. The device driver receives packets from an upper layer.
2. An available DP83816 transmit descriptor is allocated. The fragment information is copied from the NOS specific data structure(s) to the DP83816 transmit descriptor.
3. The driver adds this descriptor to its internal list of transmit descriptors awaiting transmission and sets the OWN bit.
4. If the internal list was empty (this descriptor represents the only outstanding transmit packet), then the driver must set the TXDP register to the address of this descriptor, else the driver will append this descriptor to the end of the list.
5. The driver sets the TXE bit in the CR register to insure that the transmit state machine is active.
6. If idle, the transmit state machine reads the descriptor into the TxDescriptorCache.
7. The state machine then moves through the fragment described within the descriptor, filling the TxDataFifo with data. The hardware handles all aspects of byte alignment; no alignment is assumed. Fragments may start and/or end on any byte address. The transmit state machine uses the fragment pointer and the SIZE field from the cmdsts field of the current descriptor to keep the TxDataFifo full. It also uses the MORE bit and the SIZE field from the cmdsts field of the current descriptor to know when packet boundaries occur.
8. When a packet has completed transmission (successful or unsuccessful), the state machine updates the upper half of the cmdsts field of the current descriptor in main memory, relinquishing ownership, and indicating the packet completion status. This update is done by a bus master transaction that transfers only the upper 2 bytes to the descriptor being updated. If more than one descriptor was used to describe the packet, then completion status is updated only in the last descriptor. Intermediate descriptors only have the OWN bits modified.
9. If the link field of the descriptor is non-zero, the state machine advances to the next descriptor and continues.
10. If the link field is NULL, the transmit state machine suspends, waiting for the TXE bit in the CR register to be set. If the TXDP register is written to, the CTDD flag will be cleared. When the TXE bit is set, the state machine will examine CTDD. If CTDD is set, the state machine will "refresh" the link field of the current descriptor. It will then follow the link field to any new descriptors that have been added to the end of the list. If CTDD is clear (implying that TXDP has been written to), the state machine will start by reading in the descriptor pointed to by TXDP.

## 5.0 Buffer Management (Continued)

### 5.3 Receive Architecture

The receive architecture is as "symmetrical" to the transmit architecture as possible. The receive buffer manager prefetches receive descriptors to prepare for incoming

packets. When the amount of receive data in the RxDataFIFO is more than the RxDrainThreshold, or the RxDataFIFO contains a complete packet, then the state machine begins filling received buffers in host memory.

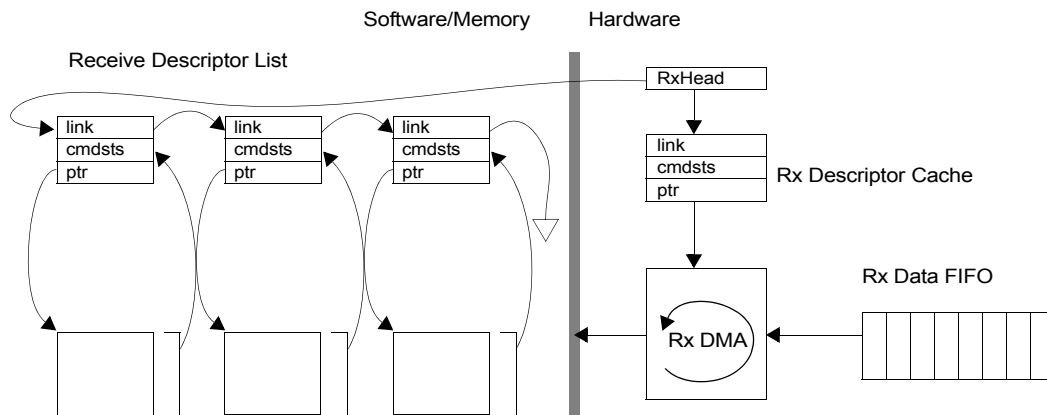

Figure 5-6 Receive Architecture

When the RXE bit is set to 1 in the CR register (regardless of the current state), and the DP83816 receive state machine is idle, then DP83816 will read the contents of the descriptor referenced by RXDP into the Rx Descriptor Cache. The Rx Descriptor Cache allows the DP83816 to

read an entire descriptor in a single burst, and reduces the number of bus accesses required for fragment information to 1. The DP83816 Rx Descriptor Cache holds a single buffer pointer/count combination.

#### 5.3.1 Receive State Machine

The receive state machine has the following states:

- rxIdle            The receive state machine is idle.
- rxDescRefr     Waiting for the "refresh" transfer of the link field of a completed descriptor from the PCI bus.
- rxDescRead     Waiting for the transfer of a descriptor from the PCI bus into the RxDescCache.
- rxFifoBlock     Waiting for the amount of data in the RxDataFifo to reach the RxDrainThreshold or to represent a complete packet.
- rxFragWrite     Waiting for the transfer of data from the RxDataFIFO via the PCI bus to host memory.
- rxDescWrite     Waiting for the completion of the write of the cmdsts field of a receive descriptor.

The receive state machine manipulates the following internal data spaces:

- RXDP            A 32-bit register that points to the current receive descriptor.
- CRDD            An internal bit flag that is set when the current receive descriptor has been completed, and ownership has been returned to the driver. It is cleared whenever RXDP is loaded with a new value (either by the state machine, or the driver).
- RxDescCache    An internal data space equal to the size of the maximum receive descriptor supported.
- descCnt          Count of bytes available for storing receive data in all fragments described by the current descriptor.
- fragPtr          Pointer to the next unwritten byte in the current fragment.
- rxPktCnt        Number of packets in the rxDataFifo. Incremented by the MAC (the fill side of the FIFO). Decrementd by the receive state machine as packets are processed.
- rxPktBytes      Number of bytes in the current packet being drained from the rxDataFifo, that are in fact currently in the rxDataFifo (Note: packets larger than FIFO size, this number will never be greater than the FIFO size).

Inputs to the receive state machine include the following events:

- CR:RXE          The RXE bit in the Command Register has been set.
- XferDone        completion of a PCI bus transfer request.
- FifoReady        (rxPktCnt > 0) or (rxPktBytes > rxDrainThreshold)... in other words, if we have a complete packet in the FIFO (regardless of size), or the number of bytes that we do have is greater than the rxDrainThreshold, then we are ready to begin draining the rxDataFifo.

## 5.0 Buffer Management (Continued)

**Table 5-6 Receive State Tables**

State	Event	Next State	Actions
rxIdle	CR:RXE && !CRDD	rxDescRead	Start a burst transfer at address RXDP and a length derived from RXCFG.
	CR:RXE && CRDD	rxDescRefr	Start a burst transfer to refresh the link field of the current descriptor.
rxDescRefr	XferDone	rxAdvance	
rxDescRead	XferDone && !OWN	rxFIFOblock	
	XferDone && OWN	rxIdle	Set ISR:RXIDLE.
rxFIFOblock	FifoReady	rxFragWrite	Start a burst transfer from the RxDataFIFO to host memory at fragPtr. The length will be the minimum of rxPktBytes and descCnt. Decrement descCnt accordingly.
	(descCnt == 0) && (rxPktBytes > 0)	rxDescWrite	Start a burst transfer to write the status back to the descriptor, setting the OWN bit, and setting the MORE bit. We'll continue the packet in the next descriptor.
	rxPktBytes == 0	rxDescWrite	Start a transfer to write the cmdsts back to the descriptor, setting the OWN bit and clearing the MORE bit, and filling in the final receive status (CRC, FAE, SIZE, etc.).
rxFragWrite	XferDone	rxFIFOblock	
rxDescWrite	XferDone	rxAdvance	
rxAdvance	link!= NULL	rxDescRead	RXDP <- rxDescCache.link. Clear CRDD. Start a burst transfer at address RXDP with a length derived from RXCFG:MXDMA.
	link == NULL	rxIdle	Set CRDD. Set ISR:RXIDLE.

## 5.0 Buffer Management (Continued)

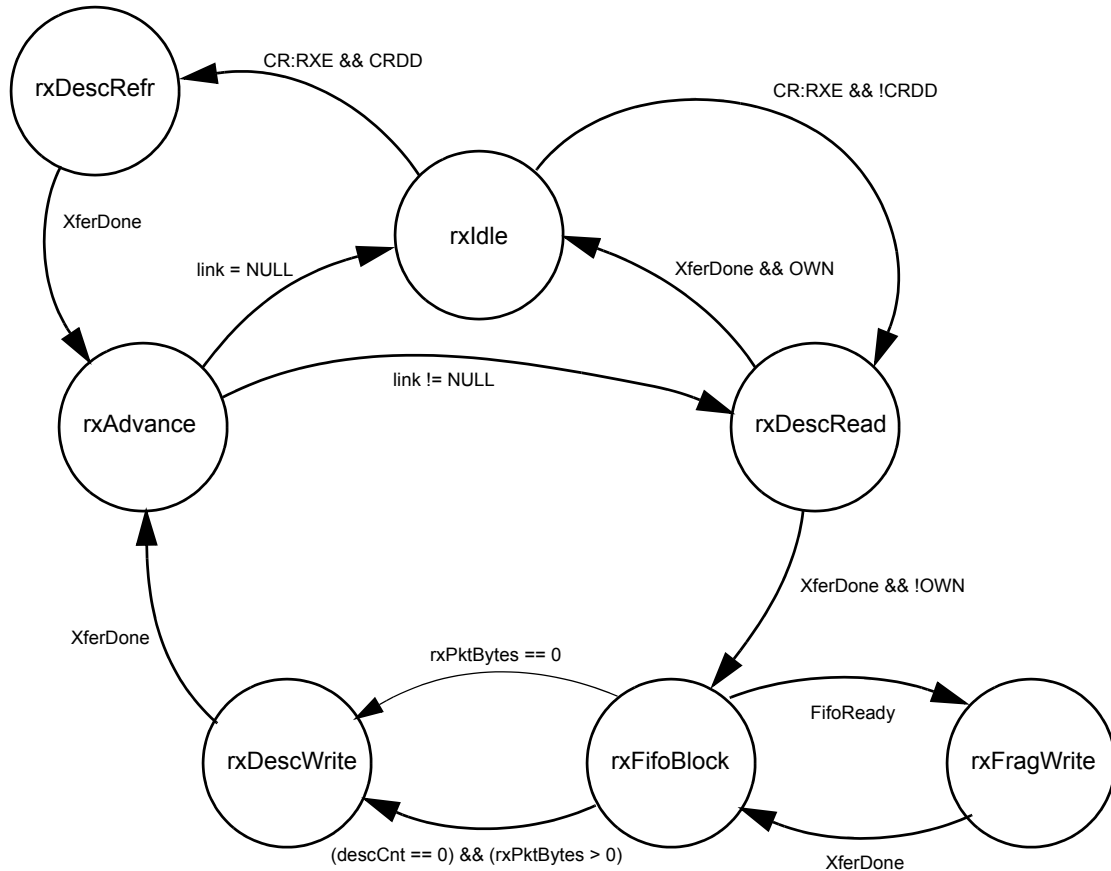

Figure 5-7 Receive State Diagram

### 5.3.2 Receive Data Flow

With a bus mastering architecture, some number of buffers and descriptors for received packets must be pre-allocated when the DP83816 is initialized. The number allocated will directly affect the system's tolerance to interrupt latency. The more buffers that you pre-allocate, the longer the system will survive an incoming burst without losing receive packets, if receive descriptor processing is delayed or preempted. Buffers sizes should be allocated in 32 byte multiples.

1. Prior to packet reception, receive buffers must be described in a receive descriptor list (or ring, if preferred). In each descriptor, the driver assigns ownership to the hardware by clearing the OWN bit. Receive descriptors may describe a single buffer.
2. The address of the first descriptor in this list is then written to the RXDP register. As packets arrive, they are placed in available buffers. A single packet may occupy one or more receive descriptors, as required by the application. The device reads in the first descriptor into the RxDescCache.

3. As data arrives in the RxDataFIFO, the receive buffer management state machine places the data in the receive buffer described by the descriptor. This continues until either the end of packet is reached, or the descriptor byte count for this descriptor is reached.

4. If end of packet was reached, the status in the descriptor (in main memory) is updated by setting the OWN bit and clearing the MORE bit, by updating the receive status bits as indicated by the MAC, and by updating the SIZE field. The status bits in cmdsts are only valid in the last descriptor of a packet (with the MORE bit clear). Also for the last descriptor of a packet, the SIZE field will be updated to reflect the actual amount of data written to the buffer (which may be less the full buffer size allocated by the descriptor).

If the receive buffer management state machine runs out of descriptors while receiving a packet, data will buffer in the receive FIFO. If the FIFO overflows, the driver will be interrupted with an RxOVR error.

## 6.0 Power Management and Wake-On-LAN

### 6.1 Introduction

The DP83816 supports Wake-On-LAN (WOL) and the PCI Power Management Specification version 1.1. These features allow the device to enter a power saving mode, and to signal the system to return to a normal operating state when a wake event occurs. This section describes the power management operation on the DP83816.

### 6.2 Definitions (for this document only)

- Power Management - a PCI specification that defines power-saving states of PCI devices and systems. A spec-compliant device implements two PCI Configuration registers to control and report status for its Power Management function.
- Wake event - An event that causes a PCI device in Power Management mode to signal the system.
- PME Enable (PMEEN) - bit 8 of the Power Management Control/Status Register (PMCSR - offset 44h in the PCI configuration space). Setting this bit to 1 allows the device to assert the PMEN pin when it detects a wake event.
- Sleep mode - A device is in sleep mode if it is programmed to a Power Management state other than the fully operational state and is not allowed to signal a wake event to the system. In this mode, the PME Enable bit is 0.
- Wake-On-LAN mode - A device is in Wake-On-LAN (WOL) mode if it is programmed to a Power Management state other than the fully operational state and is allowed to signal a wake event to the system. In this mode, the PME Enable bit is 1.
- PMEN (pin59) - this pin is similar in function to a system interrupt (INTAN pin). When asserted, it signals the system that a wake event has occurred.
- PME Status - bit 15 of PMCSR. When 1, indicates the device detected a wake event. If PME Enable is also set to 1, the device will assert PMEN whenever PME Status is 1. Software writes a 1 to this bit to clear it.

- Magic Packet™: “A specific packet of information sent to remotely wake up a sleeping or powered off PC on a network, it is handled in the LAN controller. The Magic Packet™ must contain a specific data sequence which can be located anywhere within the packet but must be preceded by a synchronization stream. The packet must also meet the basic requirements for the LAN technology chosen (e.g. ethernet frame). The specific data sequence consists of 16 duplications of the MAC address of the machine to be awakened. The synchronization stream is defined as 6 bytes of FFh.”
- ACPI-compatible operating system - An operating system that takes advantage of the PCI Power Management interface. These include Windows 98 (when installed with ACPI), Windows 2000, and Windows ME (when installed with ACPI).

### 6.3 Packet Filtering

When the PME Enable bit is set to 1, incoming packets are filtered based on settings in the Receive Filter Control Register (RFCR - offset 48h in operational registers) and the Wake Command/Status Register (WCSR - offset 40h in operational registers). In other words, a packet must pass both filters to be accepted. This is a desirable feature in WOL mode since it prevents non-wake packets from filling the receive FIFO. However, it is not desirable in normal operating mode since it will not allow non-wake packets from being received. Therefore, the driver should ensure that the PME Enable bit is set to 0 for normal operation.

### 6.4 Power Management

The Power Management Specification presents a low-level hardware interface to PCI devices for the purpose of saving power. The DP83816 supports power states D0, D1, D2, D3hot, and D3cold as defined in the PCI Power Management Specification. These states provide increasing power reduction in the order they are listed. Table 6-1 lists the different Power Management modes and the methods of power reduction in DP83816 devices.

**Table 6-1 Power Management Modes**

Power State	PME Enable (PMEEN)	Wake Conditions	Power Management Mode	PCICLK	Physical Layer Cell
D0	(SW sets to 0)	Unconfigured	Normal	On	On
D1	Don't Care	Don't Care	WOL	On	On
D2	Don't Care	Don't Care	WOL	May be Off	On
D3hot	Off	Don't Care	Sleep	May be Off	Off
D3hot	Don't Care	Unconfigured	Sleep	May be Off	Off
D3hot	On	Configured	WOL	May be Off	On
D3cold	Off	Don't Care	Sleep	Off	Off
D3cold	Don't Care	Unconfigured	Sleep	Off	Off
D3cold	On	Configured	WOL	Off	On



## 6.0 Power Management and Wake-On-LAN (Continued)

### 6.4.1 D0 State

The D0 state is the normal operational state of the device. The PME Enable bit should be set to 0 to prevent packet filtering based on the settings in the Wake Control/Status Register (WCSR). It is also advisable to turn off all WOL conditions in WCSR to prevent unnecessary PME interrupts.

### 6.4.2 D1 State

The D1 state is the least power-saving Power Management state, and might not be used by the operating system. The device will only respond to PCI configuration transactions and therefore will not transmit data. The only bus activity the device can initiate is the assertion of the PMEN pin (assuming the PME Enable bit is set to 1); no DMA activity or interrupts will occur. The device will continue to receive packets up to the limit of the receive FIFO size. Upon returning to the D0 state, the system must re-enable I/O and memory space in the device and turn on bus master capability.

### 6.4.3 D2 State

The D2 state has the same features as the D1 state, and the system may turn off the PCI clock, further reducing power. The device will continue to receive packets up to the limit of the receive FIFO size. Like the D1 state, the D2 state might not be used by the operating system.

### 6.4.4 D3hot State

The D3hot state is often known as the Standby state. If the PME Enable bit is 0, or WOL is unconfigured, the device saves power by turning off the Physical Layer Cell (PHY). The system may turn off the PCI clock. In order to receive packets in the D3hot state, both WOL mode and PME Enable must be turned on. Like the D2 and D1 states, the device will respond to PCI configuration transactions as long as the PCI clock is running.

When the device exits the D3hot state, all PCI configuration registers except for the PME Enable and PME Status bits are reset to their default values. This means the operating system must reinitialize the device's PCI configuration registers with valid base addresses, etc. If PME Enable or WOL mode were not turned on, the device must be fully reinitialized.

### 6.4.5 D3cold State

The D3cold state is the highest power-saving state; it is often known as the Hibernate state. The PCI bus is turned off, as is the PCI clock. If the PME Enable bit or WOL is turned off, the PHY is turned off. This allows the device to consume the least amount of power. The device must be fully reinitialized after exiting this mode.

## 6.5 Wake-On-LAN (WOL) Mode

Wake-On-LAN Mode is a system-level function that allows a network device to alert the system that a wake event has occurred. It works in conjunction with the PCI Power Management states detailed in the previous section. The DP83816 supports several wake events including, but not limited to, Wake on PHY Interrupt (i.e. link change), Wake on Magic Packet™, and Wake on Pattern Match. The supported wake events appear in the device's Wake Command/Status Register (WCSR).

### 6.5.1 Entering WOL Mode

The following steps are required to place the DP83816 into WOL mode:

1. Disable the receiver by writing a 1 to the Receiver Disable bit 3 (RXD) in the Command Register (CR - offset 00h in operational registers).
2. Write 0 to the Receive Descriptor Pointer Register (RXDP - offset 30h in operational registers) to reset the receive pointer.
3. Enable the receiver (now in "silent receive" mode) by writing a 1 to the Receiver Enable bit 2 in the Command Register (CR:RXE).
4. Configure the Receive Filter Control Register (RFCR) to enable the receive filter (RFCR:RFEN - bit 31) and accept the desired type of wakeup packets. Note that the Receive Filter Enable bit must be set to 1 for Wake on PHY Interrupt as well.
5. If Wake on PHY Interrupt is desired, additionally configure registers MICR (offset C4h in operational registers) and MISR (offset C8h in operational registers).
6. Configure the Wake Command/Status Register (WCSR) with the desired type of wake events. An ACPI-compatible operating system should notify the driver of these events.
7. Write a 1 to PME Enable, and set the desired Power State in PMCSR. These can be done in one operation, or PME Enable can be written first. An ACPI-compatible operating system should handle this step.
8. If the Power Management state is D3cold, the system will assert PCI reset, stop the PCI clock, and remove power from the PCI bus.

The following two examples show the corresponding register settings for Wake on Magic Packet™ mode and Wake on PHY Interrupt mode respectively:

#### Entering Wake on Magic Packet™ mode:

1. CR = 00000008h (disable the receiver)
2. RXDP = 00000000h (reset the receive pointer)
3. CR = 00000004h (enable the receiver)
4. RFCR = F0000000h (enables the receive filter and allows Broadcast, Multicast and Unicast packets to be received - a Magic Packet™ could be any of those.)
5. WCSR = 00000200h (sets the Wake on Magic Packet™ bit)
6. PMCSR = 00008103h (clears the PME status bit 15, sets the PME Enable bit 8 and sets the Power State bits [1:0] to D3hot)

#### Entering Wake on PHY Interrupt mode:

1. CR = 00000008h (disable the receiver)
2. RXDP = 00000000h (reset the receive pointer)
3. CR = 00000004h (enable the receiver)
4. RFCR = 80000000h (enables the receive filter)
5. MICR = 00000002h (sets the Interrupt Enable bit 1)
6. MISR = 00000000h (unmasks the change of link status event)
7. WCSR = 00000001h (sets the Wake on PHY interrupt bit)
8. PMCSR = 00008103h (clears the PME status bit 15, sets the PME Enable bit 8 and sets the Power State bits [1:0] to D3hot)

## 6.0 Power Management and Wake-On-LAN (Continued)

### 6.5.2 Wake Events

If the device detects a wake event while in WOL mode, it will assert the PMEN pin low to signal the system that a wake event has occurred. The system should then bring the device out of WOL mode as described below.

### 6.5.3 Exiting WOL Mode

The following steps are required to bring the device out of WOL mode (with or without an accompanying wake event):

1. If the Power Management state is D3cold, the system will assert PCI reset, restore PCI bus power, and restart the PCI clock. This will also return the Power State to D0. The PCI configuration registers (i.e. base addresses, bus master enable, etc.) must be reinitialized.
2. Write a 0 to Power State bits [0:1] in the PMCSR (in case the WOL Power State was not D3hot or D3cold) and PME Enable. These can be done in one operation, or Power State can be written first. Turning off PME Enable will cause the device to de-assert the PMEN pin, if it was asserted.
3. If the WOL Power State was D3hot or D3cold, reinitialize the PCI configuration registers (i.e. base addresses, bus master enable, etc.). An ACPI-compatible operating system should handle this step. Note that operational registers will not be accessible until this step is completed.
4. If a wake event occurred, read the WCSR to determine what the event was.
5. Write a 1 to PME Status. This will clear any wake event in the device. An ACPI-compatible operating system will perform this write to the PMCSR; a driver can perform this write using the Clockrun Control/Status Register (CCSR).
6. If the wake event was a PHY interrupt from an internal PHY, clear the event in the PHY registers. Refer to the MISR in Section 4.3.11.
7. Clear all bits in WCSR.
8. Disable the receiver by writing a 1 to the Receiver Disable bit in the Command Register (CR:RXD).
9. Reconfigure RFCR as appropriate for normal operation.
10. Write a valid receive descriptor pointer to the Receive Descriptor Pointer Register (RXDP)
11. Enable the receiver by writing a 1 to the Receiver Enable bit in the Command Register (CR:RXE). If the wake event was a packet, this will now be emptied from the receive FIFO via DMA.

### 6.6 Sleep Mode

Sleep Mode is a system-level function that allows a device to be placed in a lower power mode than WOL mode. In sleep mode, the device will not be able to detect wake events or signal the system that it needs service.

#### 6.6.1 Entering Sleep Mode

The following steps are required to enter Sleep Mode:

1. Disable the receiver by writing a 1 to the Receiver Disable bit in the Command Register (CR:RXD).
2. Write 0 to the Receive Descriptor Pointer Register (RXDP)
3. Force the receiver to reread the descriptor pointer by writing a 1 to the Receiver Enable bit in the Command Register (CR:RXE).
4. Do not configure any wake events in WCSR.
5. Write a 0 to PME Enable, and set the desired Power State in PMCSR. These can be done in one operation. An ACPI-compatible operating system should handle this step.
6. If the Power Management state is D3cold, the system will assert PCI reset, stop the PCI clock, and remove power from the PCI bus.

#### 6.6.2 Exiting Sleep Mode

The following steps are required to bring the DP83816 out of Sleep Mode:

1. If the Power Management state is D3cold, the system will assert PCI reset, restore PCI bus power, and restart the PCI clock. This will also return the Power State to D0. The PCI configuration registers (i.e. base addresses, bus master enable, etc.) must be reinitialized.
2. Write a 0 to Power State bits [0:1] in the PMCSR (in case the sleep Power State was not D3hot or D3cold).
3. If the sleep Power State was D3hot or D3cold, reinitialize addresses, bus master enable, etc.). An ACPI-compatible operating system should handle this step. Note that operational registers will not be accessible until this step is completed.
4. Disable the receiver by writing a 1 to the Receiver Disable bit in the Command Register (CR:RXD).
5. Write a valid receive descriptor pointer to the Receive Descriptor Pointer Register (RXDP)
6. Enable the receiver by writing a 1 to the Receiver Enable bit in the Command Register (CR:RXE).

### 6.7 Pin Configuration for Power Management

Refer to Table 6-2 for proper pin connection for power management configuration:

**Table 6-2 PM Pin Configuration**

Pin Name	Pin No.	Power Mgt	No Power Mgt
PMEN	59	*PME#	3.3V
3VAUX	122	*3.3Vaux	GND

Note: \*Refer to Demo Board schematics for additional information.

## 7.0 DC and AC Specifications

### Absolute Maximum Ratings

Supply Voltage ( $V_{DD}$ )	-0.5 V to 3.6 V
DC Input Voltage ( $V_{IN}$ )	-0.5 V to 5.5 V
DC Output Voltage ( $V_{OUT}$ )	-0.5 V to $V_{DD} + 0.5$ V
Storage Temperature Range ( $T_{STG}$ )	-65 °C to 150 °C
Power Dissipation ( $P_D$ )	504 mW
Lead Temp. ( $T_L$ ) (Soldering, 10 sec)	260 °C
ESD Rating ( $R_{ZAP} = 1.5k\Omega$ , $C_{ZAP} = 120$ pF)	2.0 KV
ESD for TPTD $\pm$ pins only	1.0 KV
$\theta_{ja}$ (@0 cfm, 0.5 Watt)	46.4 °C/W
$\theta_{jc}$ (@1 Watt)	9.29 °C/W

### Recommended Operating Conditions

Supply voltage ( $V_{DD}$ )	3.3 Volts $\pm$ 0.3V
Normal Operating Temperature ( $T_A$ )	0 to 70 °C

Note: Absolute maximum ratings are values beyond which operation is not recommended or guaranteed. Extended exposure beyond these limits may affect device reliability. They are not meant to imply that the device should be operated at these limits.

### 7.1 DC Specifications

$T_A = 0^\circ\text{C}$  to  $70^\circ\text{C}$ ,  $V_{DD} = 3.3$  V  $\pm 0.3$ V, unless otherwise specified

Symbol	Parameter	Conditions	Min	Typ	Max	Units
$V_{OH}$	Minimum High Level Output Voltage	$I_{OH} = -6$ mA (Note 1)	$V_{DD} - 0.5$			V
$V_{OL}$	Maximum Low Level Output Voltage	$I_{OL} = 6$ mA (Note 1)			0.4	V
$V_{IH}$	Minimum High Level Input Voltage	(Note 1)	2.0			V
$V_{IL}$	Maximum Low Level Input Voltage	(Note 1)			0.8	V
$I_{IN}$	Input Current	$V_{IN} = V_{DD}$ or GND	-10		10	$\mu\text{A}$
$I_{OZ}$	TRI-STATE Output Leakage Current	$V_{OUT} = V_{DD}$ or GND	-10		10	$\mu\text{A}$
$I_{DD}$	Operating Supply Current	$I_{OUT} = 0$ mA (Note 2)		116	140	mA
	WOL Standby			90	105	mA
	Sleep Mode			16	20	mA
$R_{INdiff}$	Differential Input Resistance	RD+/-	5	6		k $\Omega$
$V_{TPTD\_100}$	100 Mb/s Transmit Voltage	TD+/-	0.95	1	1.05	V
$V_{TPTDsym}$	100 Mb/s Transmit Voltage Symmetry	TD+/-		$\pm 2$		%
$V_{TPTD\_10}$	10 Mb/s Transmit Voltage	TD+/-	2.2	2.5	2.8	V
$C_{IN}$	CMOS Input Capacitance			8		pF
$C_{OUT}$	CMOS Output Capacitance			8		pF
$SD_{THon}$	100BASE-TX Signal detect turn-on threshold	RD+/-			1000	mV diff pk-pk
$SD_{THoff}$	100BASE-TX Signal detect turn-off threshold	RD+/-	200			mV diff pk-pk
$V_{TH1}$	10BASE-T Receive Threshold	RD+/-	300		585	mV

Note 1: These values ensure 3.3V and 5V compatibility.

Note 2: For  $I_{DD}$  Measurements, outputs are not loaded.

## 7.0 DC and AC Specifications (Continued)

### 7.2 AC Specifications

#### 7.2.1 PCI Clock Timing

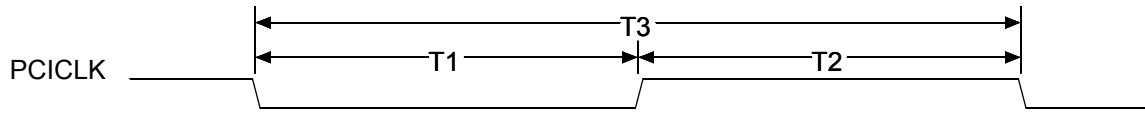

Number	Parameter	Min	Max	Units
7.2.1.1	PCICLK Low Time	12		ns
7.2.1.2	PCICLK High Time	12		ns
7.2.1.3	PCICLK Cycle Time	30	$\infty$	ns

#### 7.2.2 X1 Clock Timing

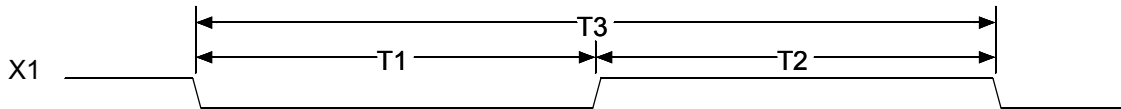

Number	Parameter	Min	Max	Units
7.2.2.1	X1 Low Time	16		ns
7.2.2.2	X1 High Time	16		ns
7.2.2.3	X1 Cycle Time	40	40	ns

## 7.0 DC and AC Specifications (Continued)

### 7.2.3 Power On Reset (PCI Active)

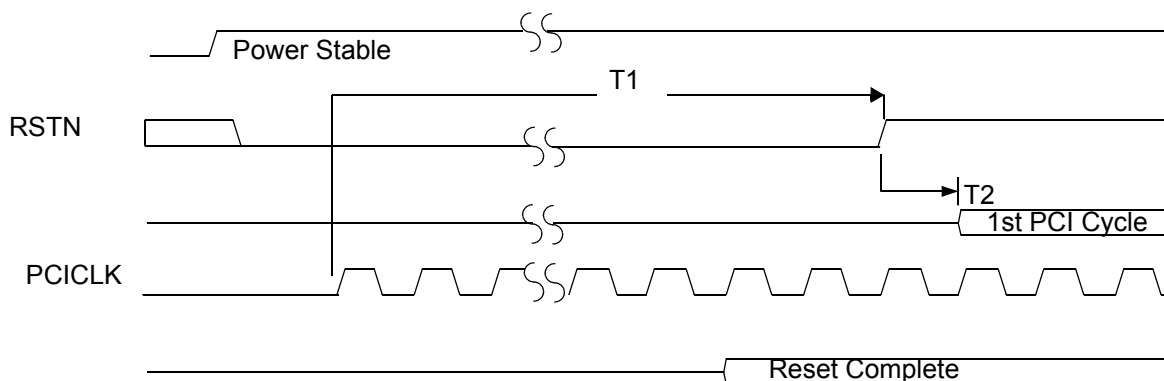

Number	Parameter	Min	Max	Units
7.2.3.1	RSTN Active Duration from PCICLK stable	1		ms
7.2.3.2	Reset Disable to 1st PCI Cycle			
	EE Enabled	1500		us
	EE Disabled	1		us

Note: Minimum reset complete time is a function of the PCI, transmit, and receive clock frequencies.

Note: Minimum access after reset is dependent on PCI clock frequency. Accesses to DP83816 during this period will be ignored.

Note: EE is disabled for non power on reset.

### 7.2.4 Non Power On Reset

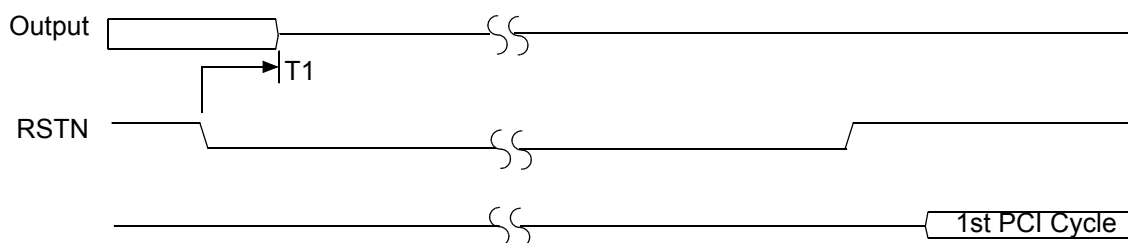

Number	Parameter	Min	Max	Units
7.2.4.1	RSTN to Output Float		40	ns

Note: Minimum reset complete time is a function of the PCI, transmit, and receive clock frequencies.

**7.0 DC and AC Specifications** (Continued)

**7.2.5 POR PCI Inactive**

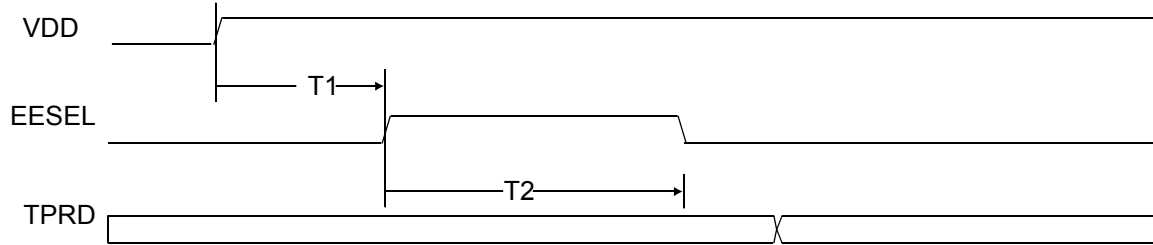

Number	Parameter	Min	Max	Units
7.2.5.1	VDD stable to EE access VDD indicates the digital supply (AUX power plane, except PCI bus power.) Guaranteed by design.		60	us
7.2.5.2	EE Configuration load duration		2000	us

## 7.0 DC and AC Specifications (Continued)

### 7.2.6 PCI Bus Cycles

The following table parameters apply to **ALL** the PCI Bus Cycle Timing Diagrams contained in this section.

Number	Parameter	Min	Max	Units
7.2.6.1	Input Setup Time	7		ns
7.2.6.2	Input Hold Time	0		ns
7.2.6.3	Output Valid Delay	2	11	ns
7.2.6.4	Output Float Delay ( $t_{off}$ time)		28	ns
7.2.6.5	Output Valid Delay for REQN - point to point	2	12	ns
7.2.6.6	Input Setup Time for GNTN - point to point	10		ns

#### PCI Configuration Read

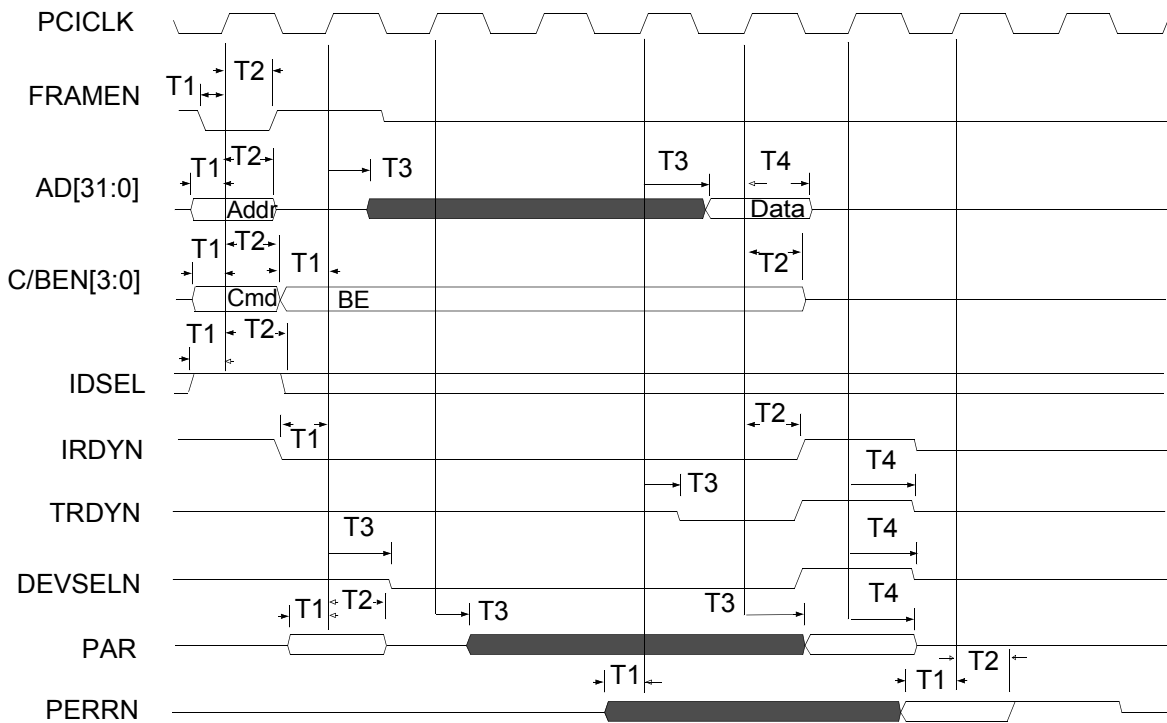

## 7.0 DC and AC Specifications (Continued)

### PCI Configuration Write

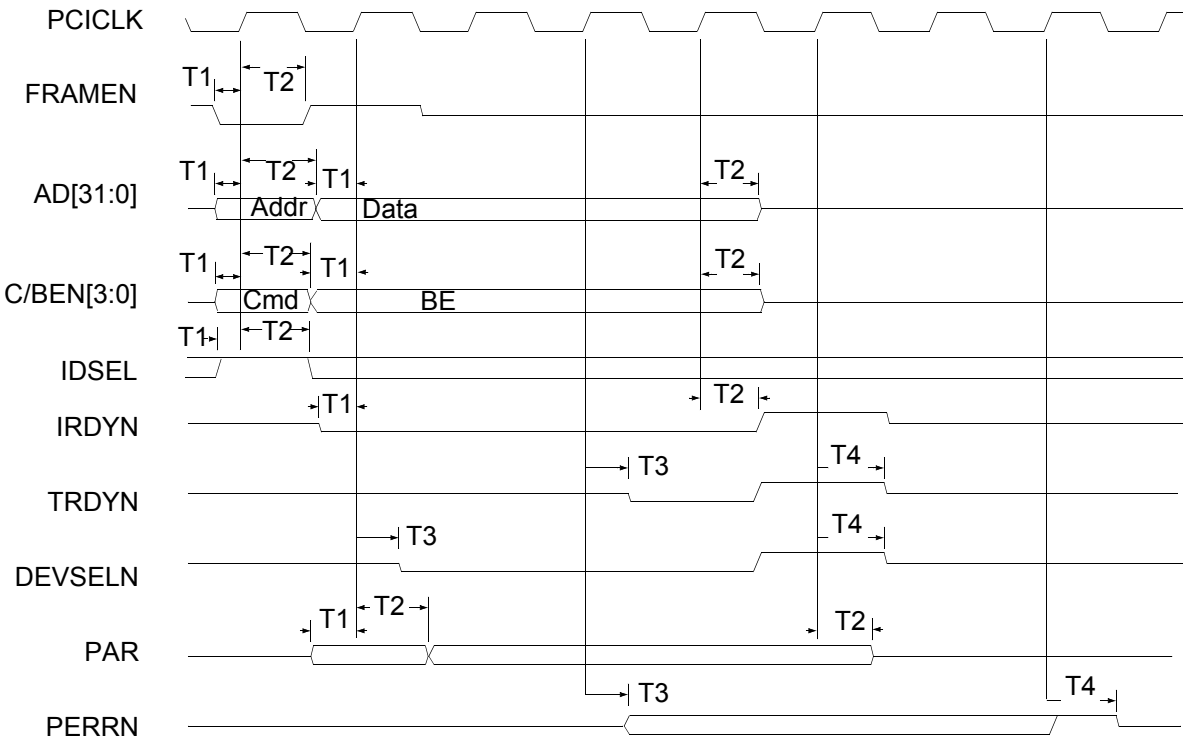

### PCI Bus Master Read

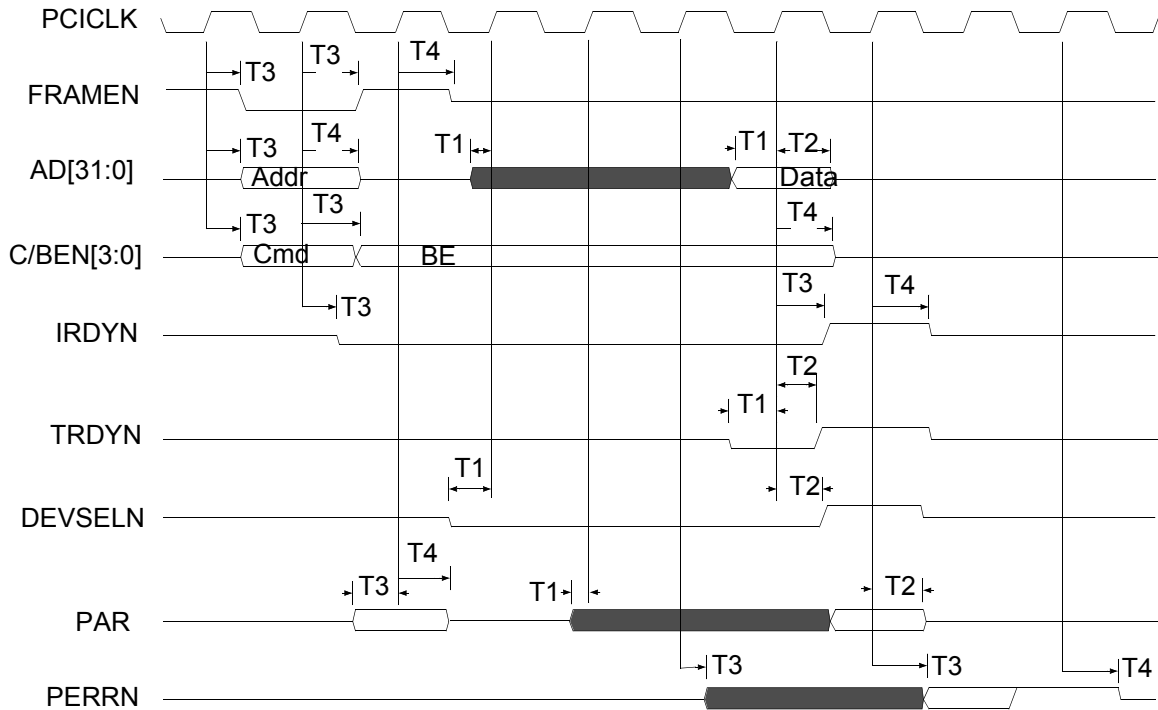



## 7.0 DC and AC Specifications (Continued)

### PCI Bus Master Write

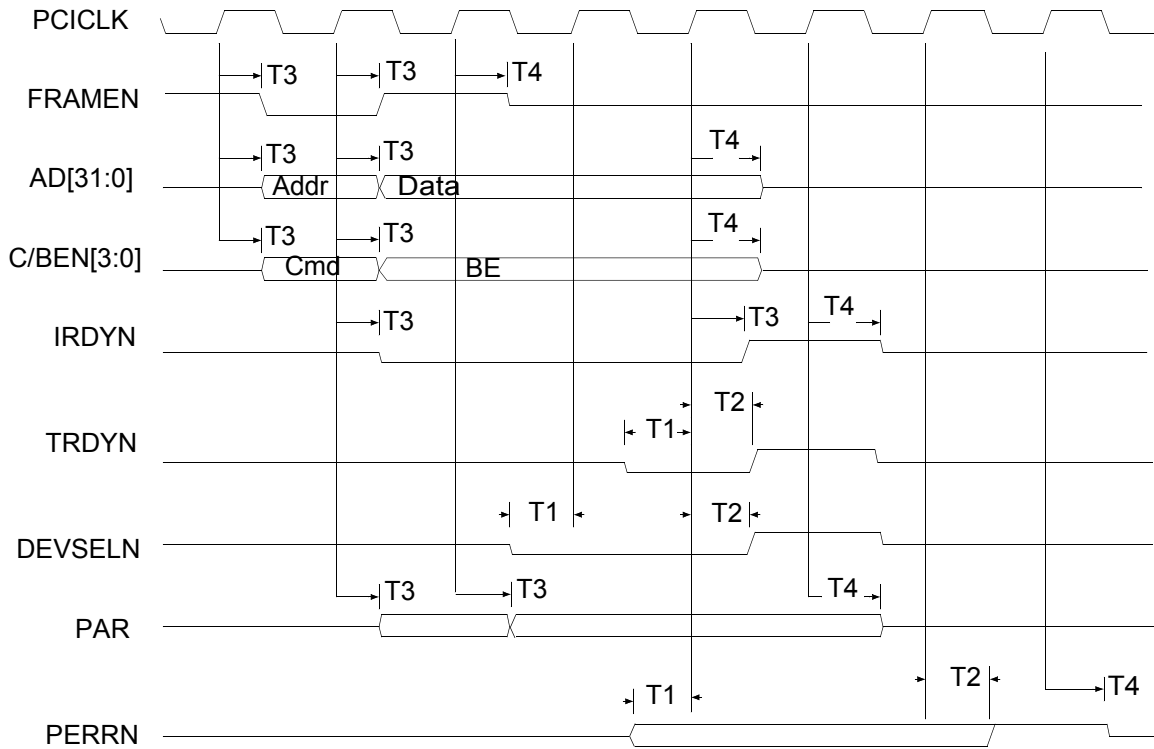

### PCI Target Read

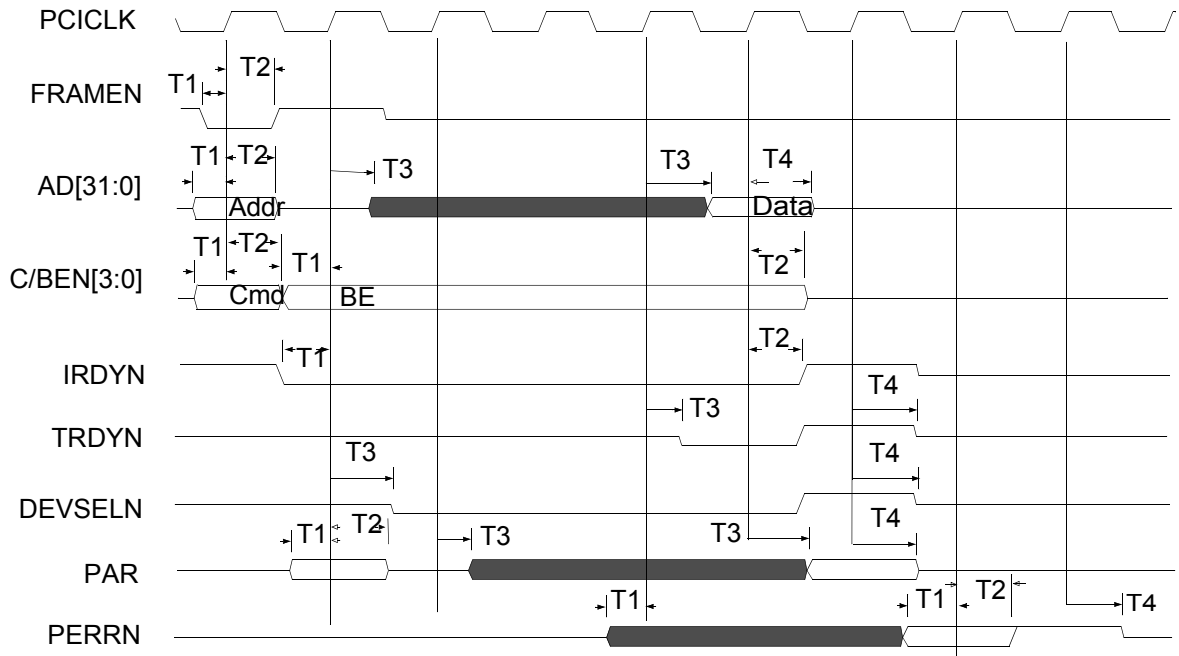

## 7.0 DC and AC Specifications (Continued)

### PCI Target Write

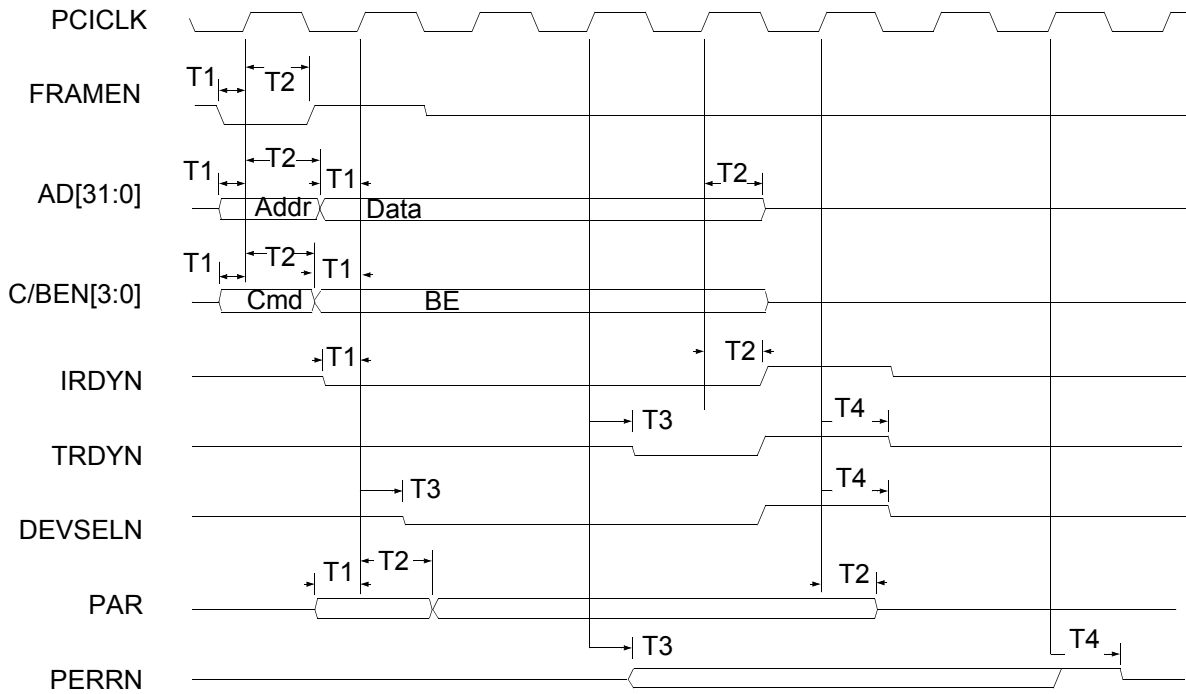

### PCI Bus Master Burst Read

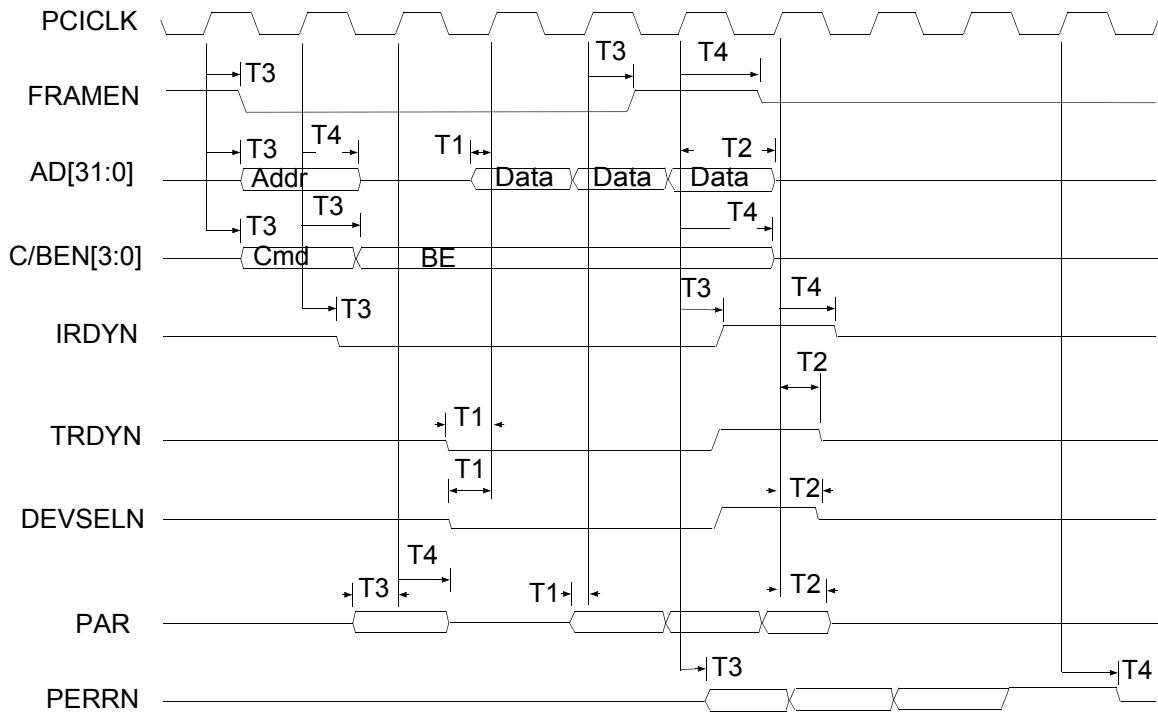

## 7.0 DC and AC Specifications (Continued)

### PCI Bus Master Burst Write

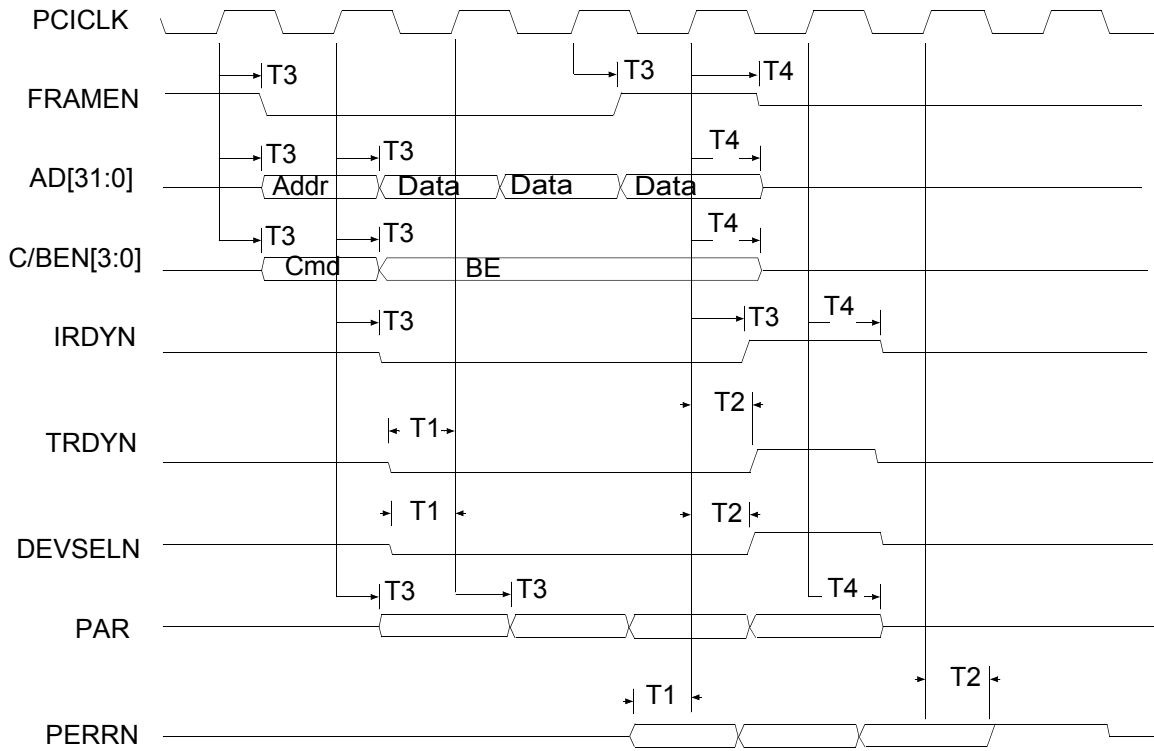

### PCI Bus Arbitration

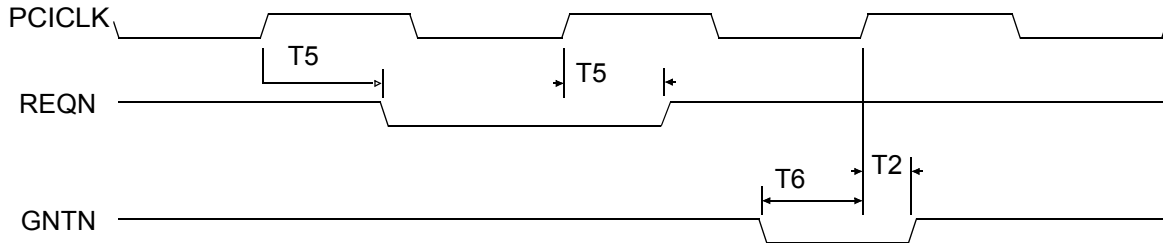

## 7.0 DC and AC Specifications (Continued)

### 7.2.7 EEPROM Auto-Load

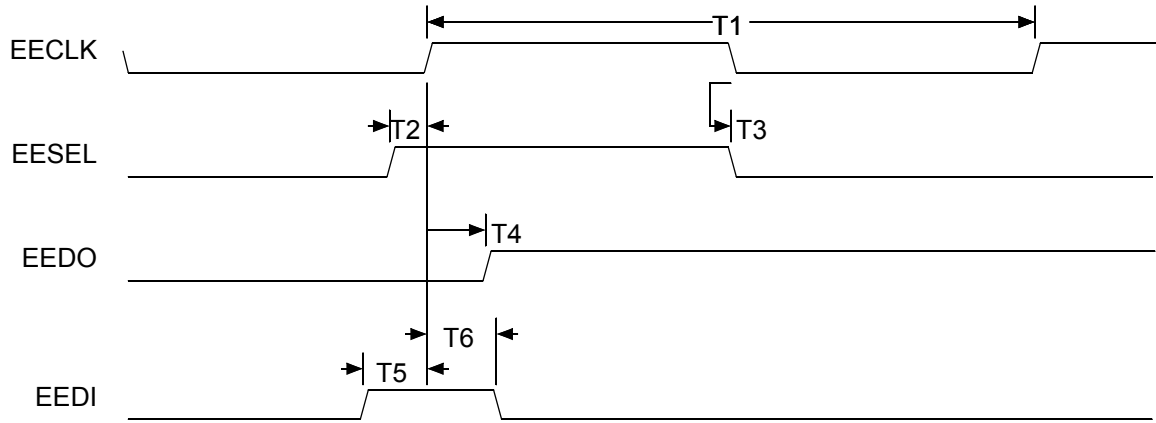

Refer to NM93C46 data sheet

Number	Parameter	Min	Max	Units
7.2.7.1	EECLK Cycle Time	4		us
7.2.7.2	EECLK Delay from EESEL Valid	1		us
7.2.7.3	EECLK Low to EESEL Invalid	2		us
7.2.7.4	EECLK to EEDO Valid		2	us
7.2.7.5	EEDI Setup Time to EECLK	2		us
7.2.7.6	EEDI Hold Time from EECLK	2		us

## 7.0 DC and AC Specifications (Continued)

### 7.2.8 Boot PROM/FLASH

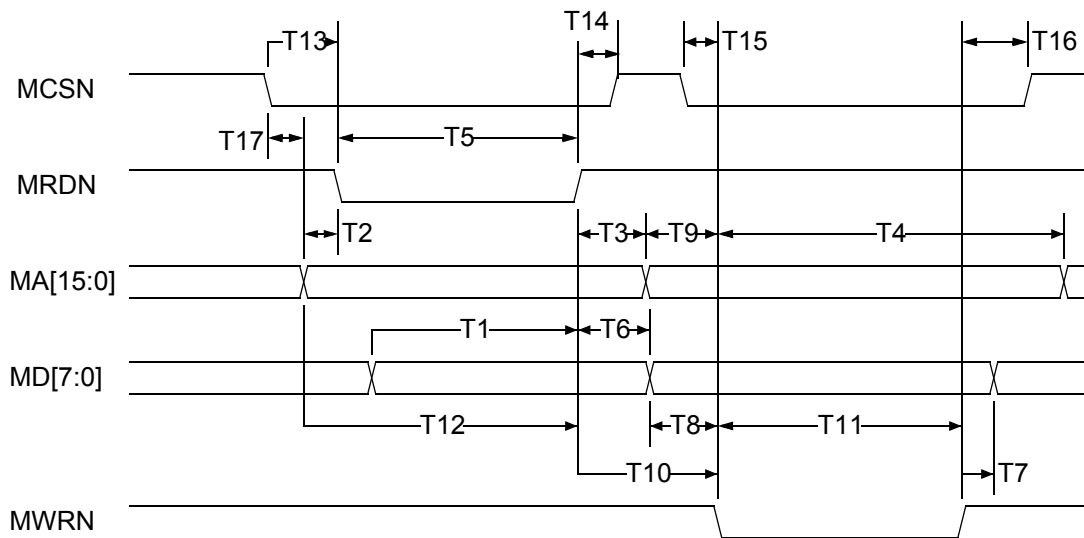

Number	Parameter	Min	Typ	Units
7.2.8.1	Data Setup Time to MRDN Invalid	20		ns
7.2.8.2	Address Setup Time to MRDN Valid		30	ns
7.2.8.3	Address Hold Time from MRDN Invalid		0	ns
7.2.8.4	Address Invalid from MWRN Valid		180	ns
7.2.8.5	MRDN Pulse Width		180	ns
7.2.8.6	Data Hold Time from MRDN Invalid	0		ns
7.2.8.7	Data Invalid from MWRN Invalid		60	ns
7.2.8.8	Data Valid to MWRN Valid		30	ns
7.2.8.9	Address Setup Time to MWRN Valid		30	ns
7.2.8.10	MRDN Invalid to MWRN Valid	150		ns
7.2.8.11	MWRN Pulse Width		150	ns
7.2.8.12	Address/MRDN Cycle Time		210	ns
7.2.8.13	MCSN Valid to MRDN Valid		30	ns
7.2.8.14	MCSN Invalid to MRDN Invalid		0	ns
7.2.8.15	MCSN Valid to MWRN Valid		30	ns
7.2.8.16	MWRN Invalid to MCSN Invalid		30	ns
7.2.8.17	MCSN Valid to address Valid		0	ns

Note: T10 is guaranteed by design.

Note: Timings are based on a 30ns PCI clock period.

## 7.0 DC and AC Specifications (Continued)

### 7.2.9 100BASE-TX Transmit

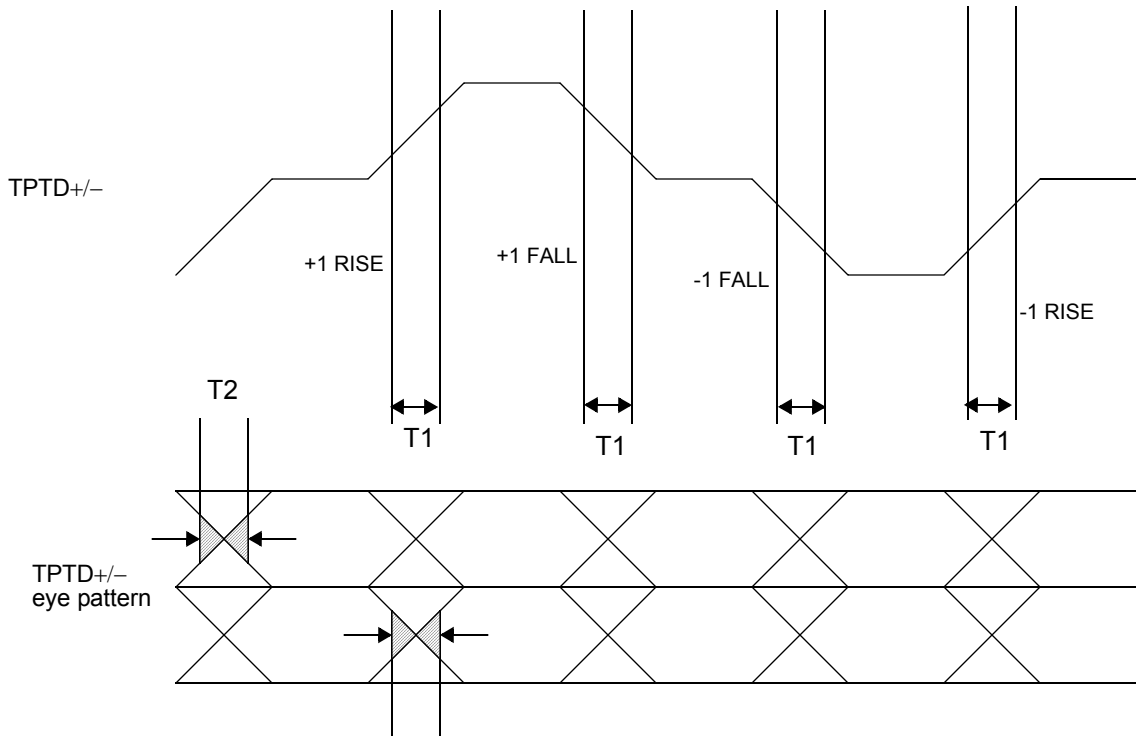

Parameter	Description	Notes	Min	Typ	Max	Units
7.2.9.1	100 Mb/s TPTD+/- Rise and Fall Times	see Test Conditions section	3	4	6	ns
	100 Mb/s Rise/Fall Mismatch				500	ps
7.2.9.2	100 Mb/s TPTD+/- Transmit Jitter				1.4	ns

Note: Normal Mismatch is the difference between the maximum and minimum of all rise and fall times.

Note: Rise and fall times taken at 10% and 90% of the +1 or -1 amplitude.

Note: Carrier Sense On Delay is determined by measuring the time from the first bit of the "J" code group to the assertion of Carrier Sense.

Note: 1 bit time = 10 ns in 100 Mb/s mode.

Note: The Ideal window recognition region is  $\pm 4$  ns.

## 7.0 DC and AC Specifications (Continued)

### 7.2.10 10BASE-T Transmit End of Packet

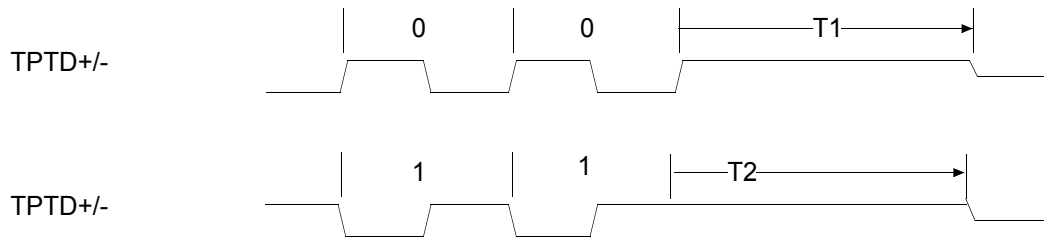

Parameter	Description	Notes	Min	Typ	Max	Units
7.2.10.1	End of Packet High Time (with '0' ending bit)	10 Mb/s	300			ns
7.2.10.2	End of Packet High Time (with '1' ending bit)	10 Mb/s	250			ns

### 7.2.11 10 Mb/s Jabber Timing

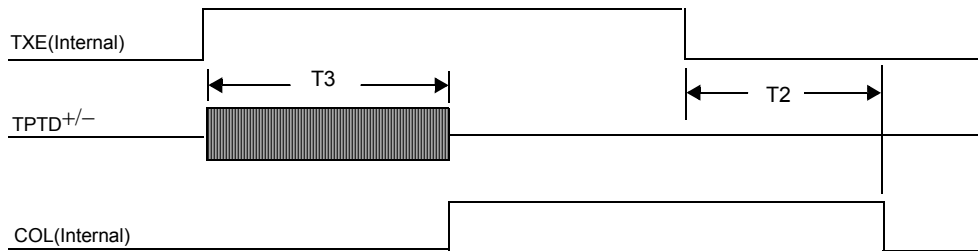

Parameter	Description	Notes	Min	Typ	Max	Units
7.2.11.1	Jabber Activation Time	10 Mb/s		85		ms
7.2.11.2	Jabber Deactivation Time	10 Mb/s		500		ms

## 7.0 DC and AC Specifications (Continued)

### 7.2.12 10BASE-T Normal Link Pulse

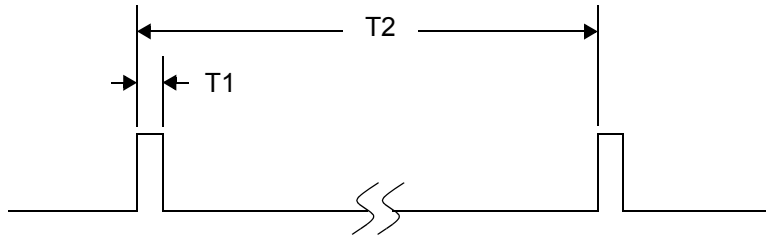

Parameter	Description	Notes	Min	Typ	Max	Units
7.2.12.1	Pulse Width			100		ns
7.2.12.2	Pulse Period			16		ms

Note: These specifications represent both transmit and receive timings

### 7.2.13 Auto-Negotiation Fast Link Pulse (FLP)

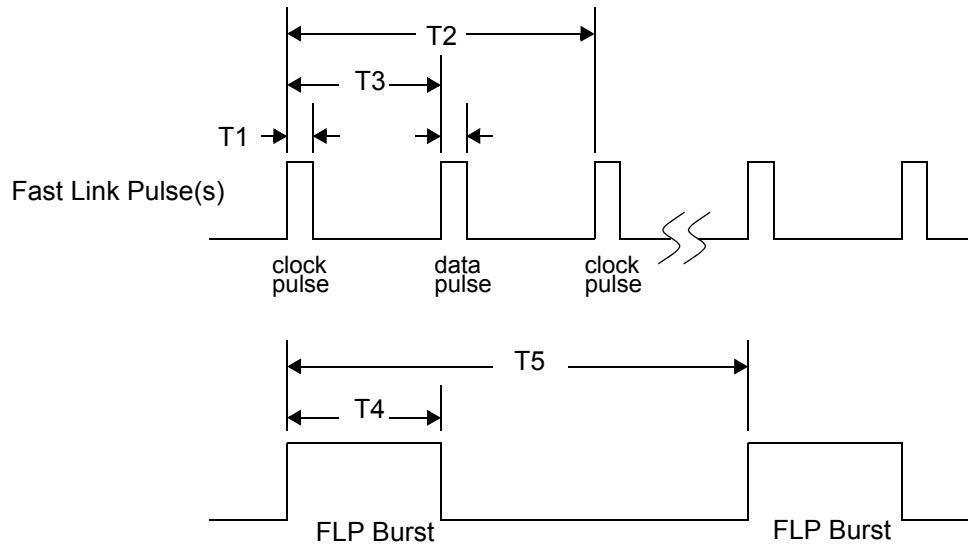

Parameter	Description	Notes	Min	Typ	Max	Units
7.2.13.1	Clock, Data Pulse Width			100		ns
7.2.13.2	Clock Pulse to Clock Pulse Period			125		$\mu$ s
7.2.13.3	Clock Pulse to Data Pulse Period	Data = 1		62.5		$\mu$ s
7.2.13.4	Burst Width			2		ms
7.2.13.5	FLP Burst to FLP Burst Period			16		ms

Note: These specifications represent both transmit and receive timings



## 7.0 DC and AC Specifications (Continued)

### 7.2.14 Media Independent Interface (MII)

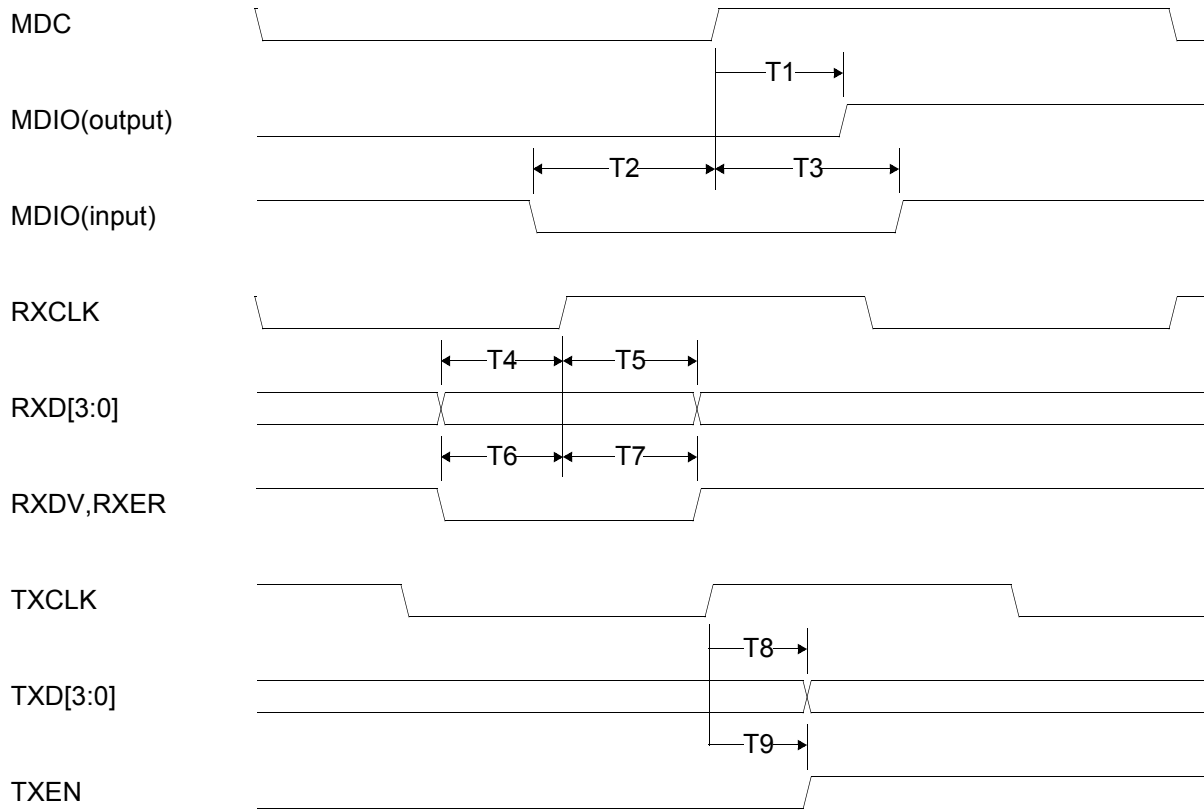

Number	Parameter	Min	Max	Units
7.2.14.1	MDC to MDIO Valid	0	300	ns
7.2.14.2	MDIO to MDC Setup	10	10	ns
7.2.14.3	MDIO from MDC Hold	10		ns
7.2.14.4	RXD to RXCLK Setup	10		ns
7.2.14.5	RXD from RXCLK Hold	10		ns
7.2.14.6	RXDV, RXER to RXCLK Setup	10		ns
7.2.14.7	RXDV, RXER from RXCLK Hold	10		ns
7.2.14.8	TXCLK to TXD Valid	0	25	ns
7.2.14.9	TXCLK to TXEN Valid	0	25	ns

Notes:

## Physical Dimensions inches (millimeters) unless otherwise noted

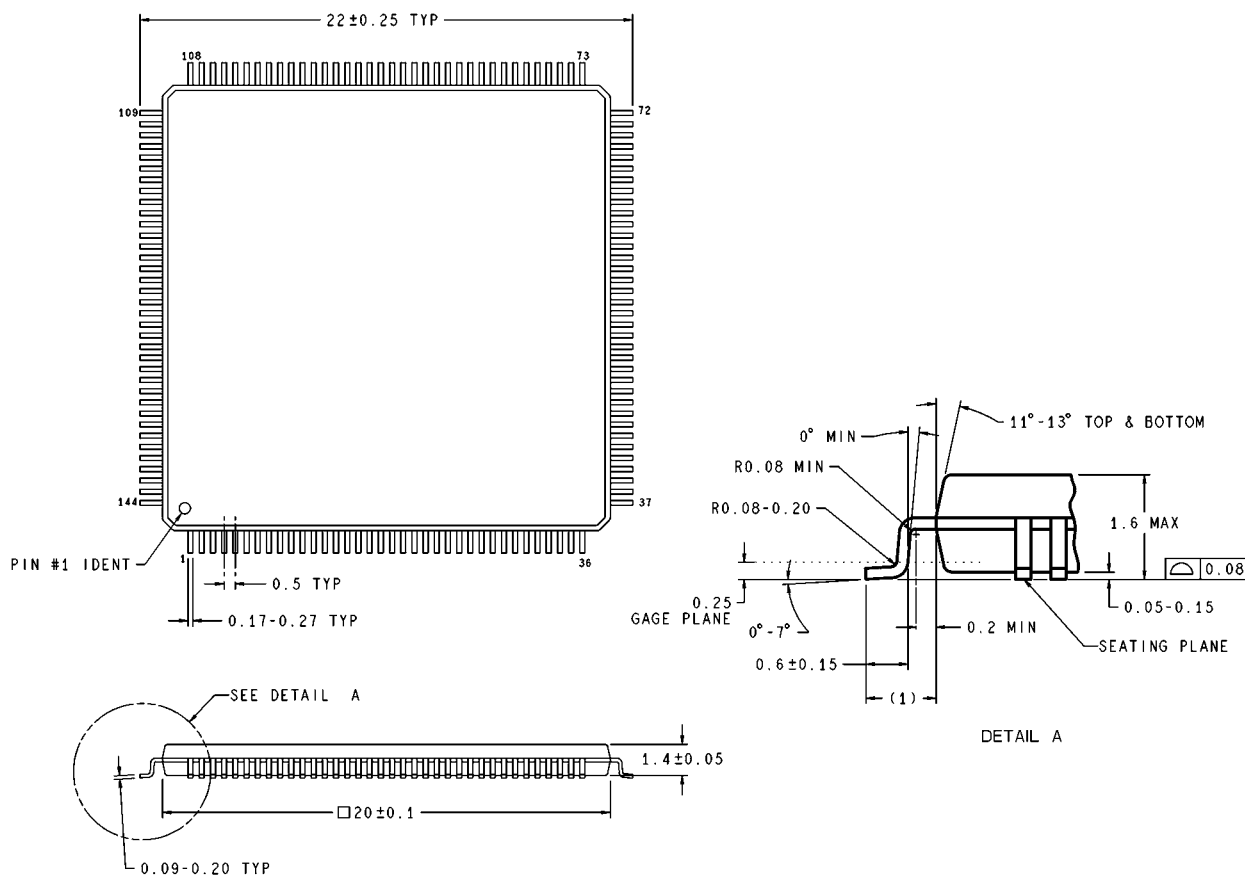

DIMENSIONS ARE IN MILLIMETERS

VNG144A (Rev E)

### NS Package Number: VNG144A

National does not assume any responsibility for use of any circuitry described, no circuit patent licenses are implied and National reserves the right at any time without notice to change said circuitry and specifications.

For the most current product information visit us at [www.national.com](http://www.national.com).

#### LIFE SUPPORT POLICY

NATIONAL'S PRODUCTS ARE NOT AUTHORIZED FOR USE AS CRITICAL COMPONENTS IN LIFE SUPPORT DEVICES OR SYSTEMS WITHOUT THE EXPRESS WRITTEN APPROVAL OF THE PRESIDENT AND GENERAL COUNSEL OF NATIONAL SEMICONDUCTOR CORPORATION. As used herein:

1. Life support devices or systems are devices or systems which, (a) are intended for surgical implant into the body, or (b) support or sustain life, and whose failure to perform, when properly used in accordance with instructions for use provided in the labeling, can be reasonably expected to result in a significant injury to the user.
2. A critical component is any component of a life support device or system whose failure to perform can be reasonably expected to cause the failure of the life support device or system, or to affect its safety or effectiveness.

#### BANNED SUBSTANCE COMPLIANCE

National Semiconductor certifies that the products and packing materials meet the provisions of the Customer Products Stewardship Specification (CSP-9-111C2) and the Banned Substances and Materials of Interest Specification (CSP-9-111S2) and contain no "Banned Substances" as defined in CSP-9-111S2.

Leadfree products are RoHS compliant.



**National Semiconductor**  
Americas Customer  
Support Center  
Email: [new.feedback@nsc.com](mailto:new.feedback@nsc.com)  
Tel: 1-800-272-9959

**National Semiconductor**  
Europe Customer Support Center  
Fax: +49 (0) 180-530 85 86  
Email: [europe.support@nsc.com](mailto:europe.support@nsc.com)  
Deutsch Tel: +49 (0) 69 9508 6208  
English Tel: +44 (0) 870 24 0 2171  
Francais Tel: +33 (0) 1 41 91 8790

**National Semiconductor**  
Asia Pacific Customer  
Support Center  
Email: [ap.support@nsc.com](mailto:ap.support@nsc.com)

**National Semiconductor**  
Japan Customer Support Center  
Fax: 81-3-5639-7507  
Email: [jpn.feedback@nsc.com](mailto:jpn.feedback@nsc.com)  
Tel: 81-3-5639-7560

## IMPORTANT NOTICE

Texas Instruments Incorporated and its subsidiaries (TI) reserve the right to make corrections, modifications, enhancements, improvements, and other changes to its products and services at any time and to discontinue any product or service without notice. Customers should obtain the latest relevant information before placing orders and should verify that such information is current and complete. All products are sold subject to TI's terms and conditions of sale supplied at the time of order acknowledgment.

TI warrants performance of its hardware products to the specifications applicable at the time of sale in accordance with TI's standard warranty. Testing and other quality control techniques are used to the extent TI deems necessary to support this warranty. Except where mandated by government requirements, testing of all parameters of each product is not necessarily performed.

TI assumes no liability for applications assistance or customer product design. Customers are responsible for their products and applications using TI components. To minimize the risks associated with customer products and applications, customers should provide adequate design and operating safeguards.

TI does not warrant or represent that any license, either express or implied, is granted under any TI patent right, copyright, mask work right, or other TI intellectual property right relating to any combination, machine, or process in which TI products or services are used. Information published by TI regarding third-party products or services does not constitute a license from TI to use such products or services or a warranty or endorsement thereof. Use of such information may require a license from a third party under the patents or other intellectual property of the third party, or a license from TI under the patents or other intellectual property of TI.

Reproduction of TI information in TI data books or data sheets is permissible only if reproduction is without alteration and is accompanied by all associated warranties, conditions, limitations, and notices. Reproduction of this information with alteration is an unfair and deceptive business practice. TI is not responsible or liable for such altered documentation. Information of third parties may be subject to additional restrictions.

Resale of TI products or services with statements different from or beyond the parameters stated by TI for that product or service voids all express and any implied warranties for the associated TI product or service and is an unfair and deceptive business practice. TI is not responsible or liable for any such statements.

TI products are not authorized for use in safety-critical applications (such as life support) where a failure of the TI product would reasonably be expected to cause severe personal injury or death, unless officers of the parties have executed an agreement specifically governing such use. Buyers represent that they have all necessary expertise in the safety and regulatory ramifications of their applications, and acknowledge and agree that they are solely responsible for all legal, regulatory and safety-related requirements concerning their products and any use of TI products in such safety-critical applications, notwithstanding any applications-related information or support that may be provided by TI. Further, Buyers must fully indemnify TI and its representatives against any damages arising out of the use of TI products in such safety-critical applications.

TI products are neither designed nor intended for use in military/aerospace applications or environments unless the TI products are specifically designated by TI as military-grade or "enhanced plastic." Only products designated by TI as military-grade meet military specifications. Buyers acknowledge and agree that any such use of TI products which TI has not designated as military-grade is solely at the Buyer's risk, and that they are solely responsible for compliance with all legal and regulatory requirements in connection with such use.

TI products are neither designed nor intended for use in automotive applications or environments unless the specific TI products are designated by TI as compliant with ISO/TS 16949 requirements. Buyers acknowledge and agree that, if they use any non-designated products in automotive applications, TI will not be responsible for any failure to meet such requirements.

Following are URLs where you can obtain information on other Texas Instruments products and application solutions:

### Products

Audio	<a href="http://www.ti.com/audio">www.ti.com/audio</a>
Amplifiers	<a href="http://amplifier.ti.com">amplifier.ti.com</a>
Data Converters	<a href="http://dataconverter.ti.com">dataconverter.ti.com</a>
DLP® Products	<a href="http://www.dlp.com">www.dlp.com</a>
DSP	<a href="http://dsp.ti.com">dsp.ti.com</a>
Clocks and Timers	<a href="http://www.ti.com/clocks">www.ti.com/clocks</a>
Interface	<a href="http://interface.ti.com">interface.ti.com</a>
Logic	<a href="http://logic.ti.com">logic.ti.com</a>
Power Mgmt	<a href="http://power.ti.com">power.ti.com</a>
Microcontrollers	<a href="http://microcontroller.ti.com">microcontroller.ti.com</a>
RFID	<a href="http://www.ti-rfid.com">www.ti-rfid.com</a>
OMAP Mobile Processors	<a href="http://www.ti.com/omap">www.ti.com/omap</a>
Wireless Connectivity	<a href="http://www.ti.com/wirelessconnectivity">www.ti.com/wirelessconnectivity</a>

### Applications

Communications and Telecom	<a href="http://www.ti.com/communications">www.ti.com/communications</a>
Computers and Peripherals	<a href="http://www.ti.com/computers">www.ti.com/computers</a>
Consumer Electronics	<a href="http://www.ti.com/consumer-apps">www.ti.com/consumer-apps</a>
Energy and Lighting	<a href="http://www.ti.com/energy">www.ti.com/energy</a>
Industrial	<a href="http://www.ti.com/industrial">www.ti.com/industrial</a>
Medical	<a href="http://www.ti.com/medical">www.ti.com/medical</a>
Security	<a href="http://www.ti.com/security">www.ti.com/security</a>
Space, Avionics and Defense	<a href="http://www.ti.com/space-avionics-defense">www.ti.com/space-avionics-defense</a>
Transportation and Automotive	<a href="http://www.ti.com/automotive">www.ti.com/automotive</a>
Video and Imaging	<a href="http://www.ti.com/video">www.ti.com/video</a>

TI E2E Community Home Page

[e2e.ti.com](http://e2e.ti.com)

Mailing Address: Texas Instruments, Post Office Box 655303, Dallas, Texas 75265  
Copyright © 2011, Texas Instruments Incorporated

# Mouser Electronics

Authorized Distributor

Click to View Pricing, Inventory, Delivery & Lifecycle Information:

[Texas Instruments:](#)

[DP83816-MAAP](#) [DP83816AVNG](#) [DP83816AVNG-EX/NOPB](#) [DP83816AVNG/63SN](#) [DP83816AVNG/NOPB](#)