

M61519FP

AUDIO SIGNAL PROCESSOR WITH SURROUND

DESCRIPTION

M61519FP is the semiconductor integrated circuit for Home Audio. M61519FP includes 2ch electronic volume, Tone control, 4 Input Selector, Bass Boost, REC output and Mic Mixing. This IC is suitable for Mini Component.

FEATURES

- 2ch Master Volume (L,R Independent Control)
 - Main Volume : 0dB to -76dB (2dB or 4dB step), -∞
 - Trim Volume : 0dB to -15dB (1dB step)
- Tone Control (Bass/Mid/Treble)
 - ±8dB(2dB step)
- 4 Input Selector with Mute
- Surround Function
- Vocal Cut Function
- Bass Boost Function
- L+R Output for Spectrum Analysis Display
- L+R Output for Subwoofer
- MIC Mixing Function
- 2 REC output with mute
- Input ATT : -5/0/+5dB
- Tone Input ATT : 0/-13dB
- External Input ATT : +3/0/-3/-6dB

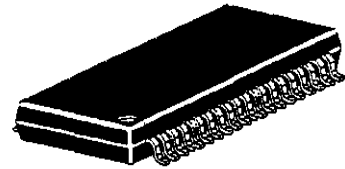

Outline 42P2R-A
0.8mm pitch 450mil ssop
(8.4mmX17.5mmX2.0mm)

APPLICATION

Mini/Micro Component ,Radio-Cassette Recorder with CD Player,etc.

RECOMMENDED OPERATING CONDITIONS

Supply voltage range.....8.0 to 10.0V
Recommended supply voltage.....9.0V

SYSTEM BLOCK DIAGRAM

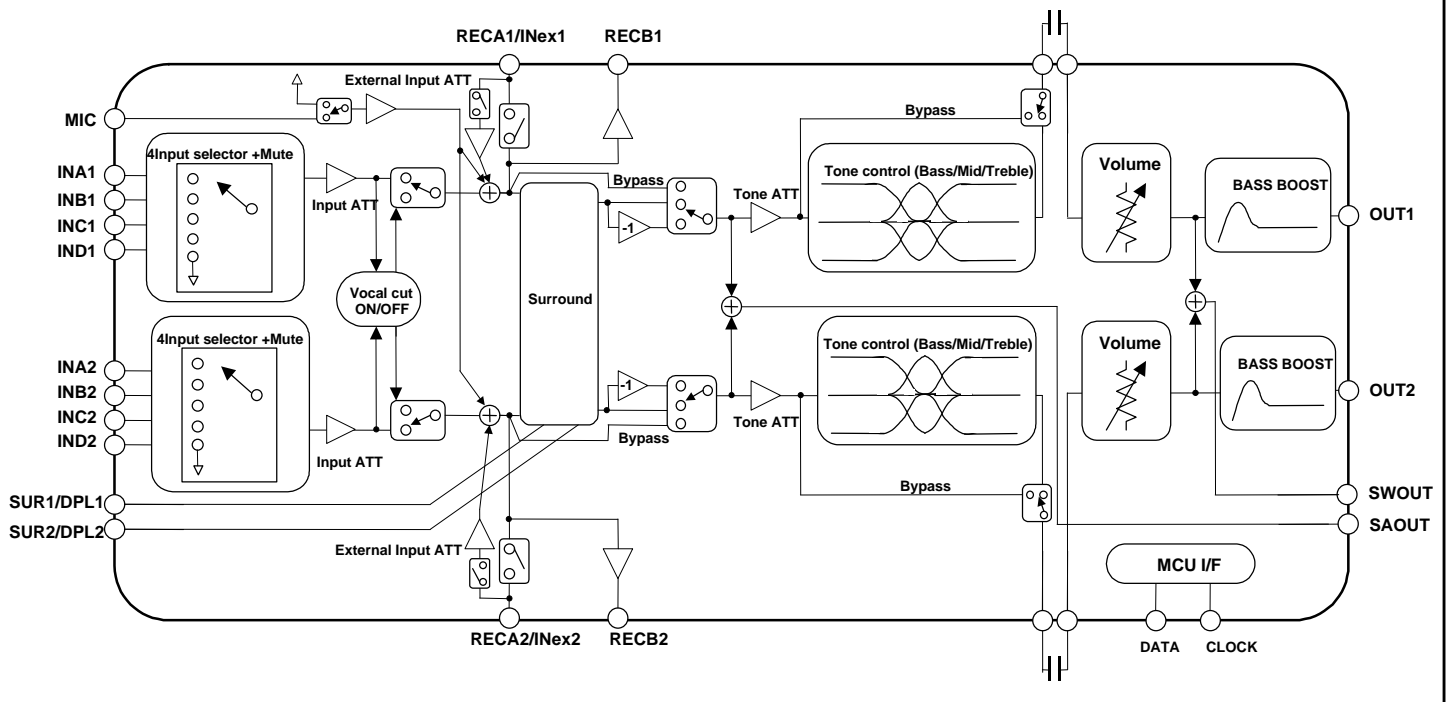

M61519FP

AUDIO SIGNAL PROCESSOR WITH SURROUND

PIN CONFIGURATION AND BLOCK DIAGRAM

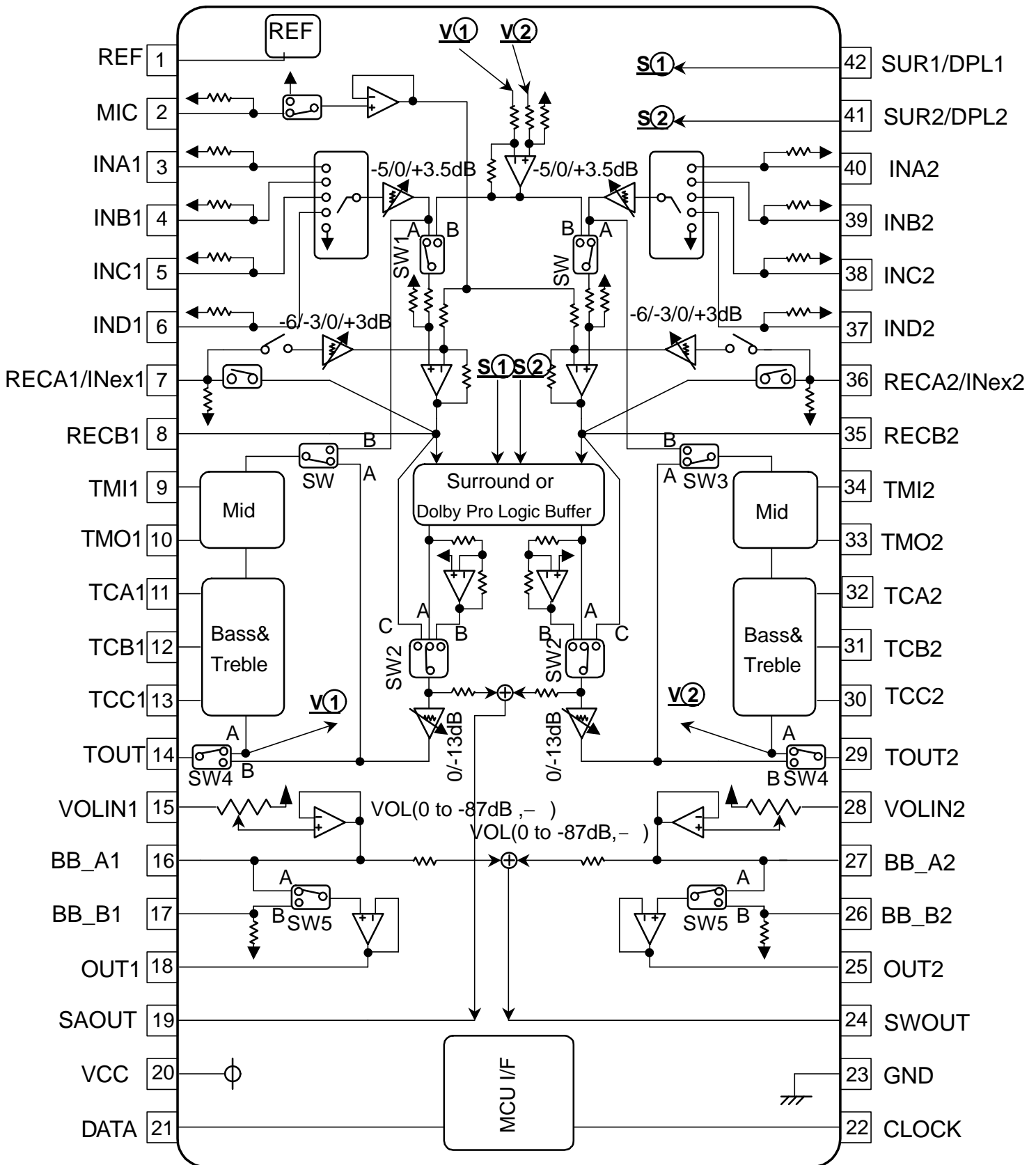

AUDIO SIGNAL PROCESSOR WITH SURROUND

PIN DESCRIPTION

Pin No.	Symbol	Function
1	REF	Input pin of internal reference (REF=4.5V)
2	MIC	Input pin of MIC Mixing
3,4,5,6 37,38,39,40	INA to IND	Input Selector
41,42	SUR/DPL	External pins for surround,Switching use with DPL Input pin
7,8,35,36	RECA/Inex,RECB	Output pins for REC,RECA can switch mute function and external Input pins (At external input,RECA Switch is fixed mute position.)
9,10,33,34	TMI,TMO	External pins for Mid (sympathetic vibration type)
11,12,13, 30,31,32	TCA,TCB,TCC	External pins for Bass/Treble (Shelving type)
14,29	TOUT	Output pins of tone control
15,28	VOLIN	Input pins of electronic volume
16,17,26,27	BB_A,BB_B	External pins for Bass boost
18,25	OUT	Output pins
19	SAOUT	Mix pins for spectrum Analyzer (L+R/2)
24	SWOUT	Mix pin for super woofer
20	VCC	Internal analog ,power pin for digital circuit
23	GND	Internal analog ,GND pin for digital circuit
21,22	DATA,CLOCK	DATA for serial data,Clock input pin

ABSOLUTE MAXIMUM RATINGS

Symbol	Parameter	Conditions	Limits	Units
VCC	Supply voltage		10.5	V
Pd	Power dissipation	$T_a \leq 25^\circ\text{C}$	850	mW
K	Thermal derating	$T_a > 25^\circ\text{C}$	8.6	mW/ °C
Topr	Operating temperature		-20 to +75	°C
Tstg	Storage temperature		-40 to +125	°C

THERMAL DERATING

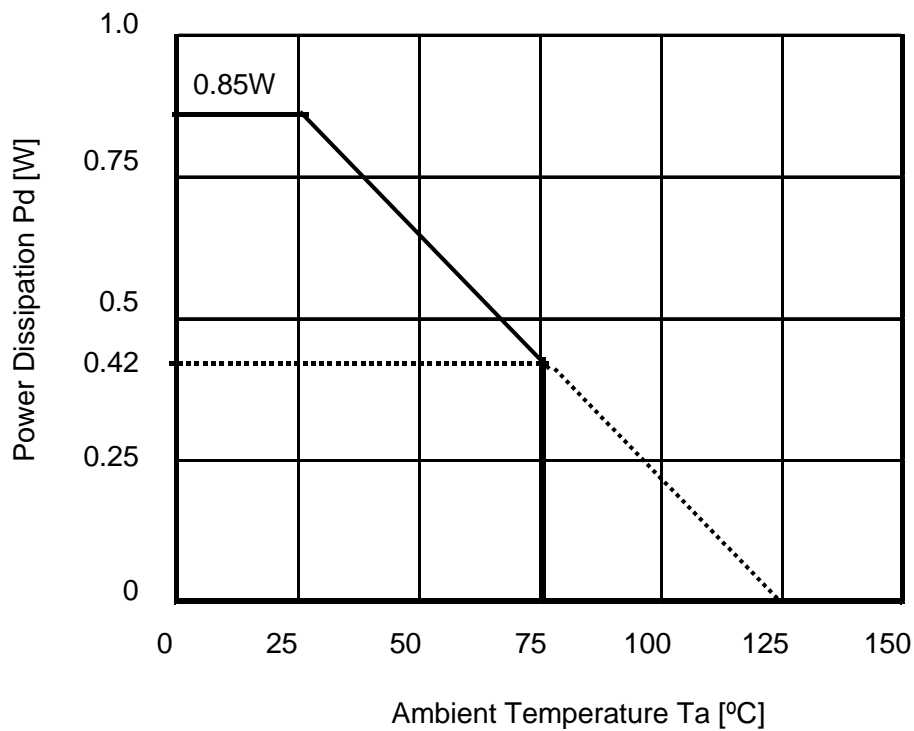

RECOMMENDED OPERATING CONDITION

(Ta=25°C, unless otherwise noted.)

Parameter	Symbol	Condition	MIN	TYP	MAX	Unit
Supply Voltage	AVDD		8	9	10	V
Logic "H" level Input voltage	VIH		2.2	—	5.5	V
Logic "L" level Input voltage	VIL		0	—	0.6	V

RELATIONSHIP BETWEEN DATA AND CLOCK AND LATCH

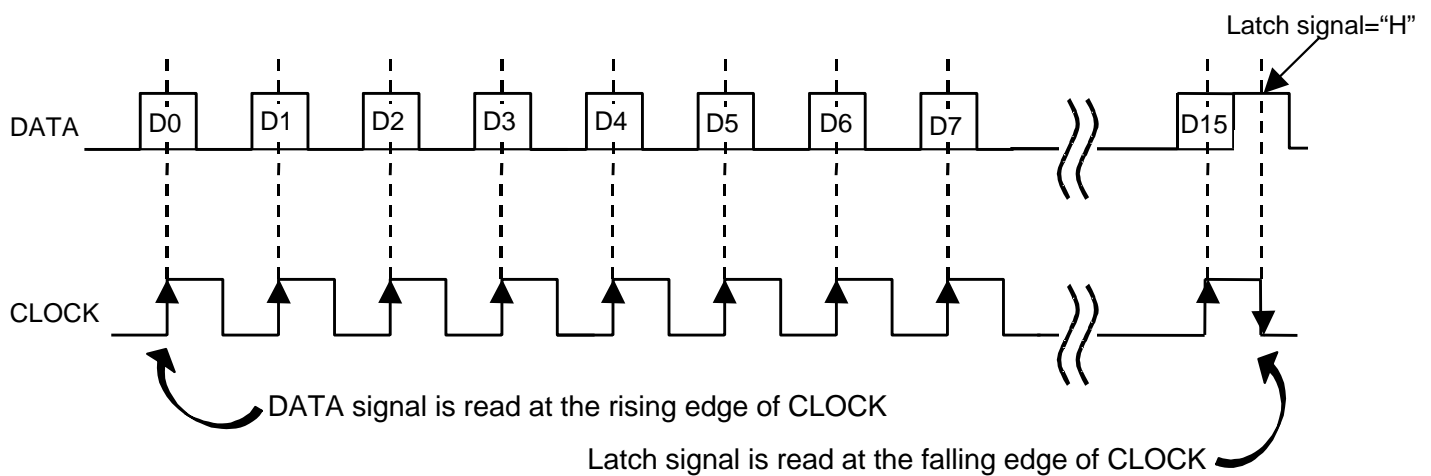

AUDIO SIGNAL PROCESSOR WITH SURROUND

DATA TIMING(Recommended conditions)

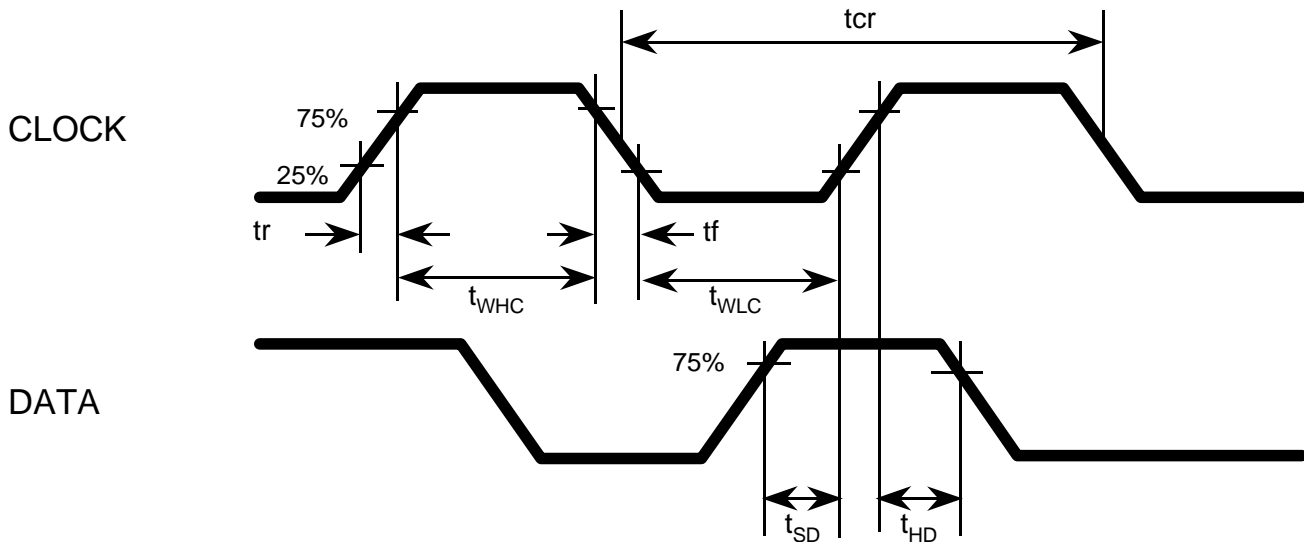

DIGITAL BLOCK TIMING REGULATION

Symbol	Parameter	Limits			Unit
		Min	typ	Max	
t_{cr}	CLOCK cycle time	4	-	-	μsec
t_{WHC}	CLOCK pulse width ("H"level)	1.6	-	-	
t_{WLC}	CLOCK pulse width ("L"level)	1.6	-	-	
t_r	CLOCK rise time	-	-	0.4	
t_f	CLOCK fall time	-	-	0.4	
t_{SD}	DATA setup time	0.8	-	-	
t_{HD}	DATA hold time	0.8	-	-	

AUDIO SIGNAL PROCESSOR WITH SURROUND

DIGITAL CONTROL SPECIFICATION

Prohibit using except specified Data code as follows.
(At power on, initial position is ● mark's setting.)

← Input direction

	D0	D1	D2	D3	D4	D5	D6	D7	D8	D9	D10	D11	D12	D13	D14	D15
A	Input Selector			Input ATT		Tone ATT	Vocal cut Tone bypass		Mic MIX	RECA/ External Input			Surround/ DPLIN		0	0
B	Tone Control SW		Tone Ccontrol Bass			Tone control Mid			Tone control Treble			0	1			
C	Lch Trim Volume			Rch Trime Volume			Bass Boost	0	0	0	0	0	0	1	0	
D	Lch Master Volume				Rch Master Volume				0	0	0	0	1	1		

(1)Input selector

Selector	D0A	D1A	D2A
INA	0	0	0
INB	0	0	1
INC	0	1	0
IND	0	1	1
Mute	1	*	*

(5)MIC Mixing

Mic Mixing	D8A
OFF	0
ON	1

(8) Switching of Tone control

Switching	D0B	D1B
Lch and Rch	0	0
Lch only	0	1
Rch only	1	0

(6)RECA / External Input

Switching	D9A	D10A	D11A
RECA-OFF	0	*	0
RECA-ON	0	*	1
+3dB	1	0	0
0dB	1	0	1
-3dB	1	1	0
-6dB	1	1	1

(9)Tone control (Bass, Mid, Treble)

Tone	D2,6,10B	D3,7,11B	D4,8,12B	D5,9,13B
+8dB	1	1	0	0
+6dB	1	0	1	1
+4dB	1	0	1	0
+2dB	1	0	0	1
0dB	0	0	0	0
-2dB	0	0	0	1
-4dB	0	0	1	0
-6dB	0	0	1	1
-8dB	0	1	0	0

(2)Input ATT

Input ATT	D3A	D4A
-5dB	0	0
0dB	0	1
+3.5dB	1	0

● At external Input setting ,RECA is OFF.

(3)Tone ATT

Tone ATT	D5A
-13dB	0
0dB	1

(7)Surround / DPLIN

Switching	D12A	D13A
Bypass	0	0
Surround	0	1
DPLIN	1	0

(4)Vocal cut & Tone bypass

Switching	D6A	D7A
Vocal cut OFF, Tone Bypass	0	0
Vocal cut OFF, Tone ON	0	1
Vocal cut ON, Tone Bypass	1	*

(11)Bass boost

Bass Boost	D8C
OFF	0
ON	1

AUDIO SIGNAL PROCESSOR WITH SURROUND

(10) Trim volume (Lch and Rch)

Trim	D0,4C	D1,5C	D2,6C	D3,7C
0dB	0	0	0	0
-1dB	0	0	0	1
-2dB	0	0	1	0
-3dB	0	0	1	1
-4dB	0	1	0	0
-5dB	0	1	0	1
-6dB	0	1	1	0
-7dB	0	1	1	1
-8dB	1	0	0	0
-9dB	1	0	0	1
-10dB	1	0	1	0
-11dB	1	0	1	1
-12dB	1	1	0	0
-13dB	1	1	0	1
-14dB	1	1	1	0
-15dB	1	1	1	1

• Total level is fixed at -87dB , on condition that the total level of Trim and Master volume is under " -87dB ".

(example: Trim -15dB , Master -76dB Total level is -87dB)

(12) Master volume(L,Rch)

Master	D0,5D	D1,6D	D2,7D	D3,8D	D4,9D
0dB	0	0	0	0	0
-2dB	0	0	0	0	1
-4dB	0	0	0	1	0
-6dB	0	0	0	1	1
-8dB	0	0	1	0	0
-10dB	0	0	1	0	1
-12dB	0	0	1	1	0
-14dB	0	0	1	1	1
-16dB	0	1	0	0	0
-18dB	0	1	0	0	1
-20dB	0	1	0	1	0
-22dB	0	1	0	1	1
-24dB	0	1	1	0	0
-26dB	0	1	1	0	1
-28dB	0	1	1	1	0
-30dB	0	1	1	1	1
-32dB	1	0	0	0	0
-34dB	1	0	0	0	1
-36dB	1	0	0	1	0
-38dB	1	0	0	1	1
-40dB	1	0	1	0	0
-42dB	1	0	1	0	1
-44dB	1	0	1	1	0
-48dB	1	0	1	1	1
-52dB	1	1	0	0	0
-56dB	1	1	0	0	1
-60dB	1	1	0	1	0
-64dB	1	1	0	1	1
-68dB	1	1	1	0	0
-72dB	1	1	1	0	1
-76dB	1	1	1	1	0
- dB	1	1	1	1	1

AUDIO SIGNAL PROCESSOR WITH SURROUND

ELECTRICAL CHARACTERISTICS

Unless otherwise noticed, Ta=25°C, VCC=9V, f=1kHz, Surround bypass, tone bypass and bass boost=OFF

Parameter	Symbol	Test Condition	Limits			Unit		
			Min.	Typ.	Max.			
Voltage	Analog positive power circuit current	Alcc	At VCC=9.0V, 20 pin terminal current and no signal			mA		
Input and Output	Input resistance	Rin	Input pin 3-6pin, 37-40pin, 2pin			kΩ		
	Maximum input voltage	VIM	(3,40)pin IN, (8,35)pin OUT RL=10kΩ, THD=1%, Input ATT=-5dB			Vrms		
	Maximum output voltage	VOM	(3,40)pin IN, (18,25)pin OUT Bass boost ON, f=100Hz, RL=10kΩ, THD=5%			Vrms		
		VrecOM	(3,40)pin IN, (7,8)(35,36)pin OUT RL=47kΩ, THD=1%, Input ATT=+3.5dB			Vrms		
	Output terminal voltage	Vodc	At No signal, (18,25)pin OUT			V		
		Vrecdc	At No signal, (8,35)pin OUT			V		
	Pass gain	Gv	Vi=1Vrms, FLAT, Gain from (3-18 pin) to (40-25 pin), Input ATT=0dB			dB		
	Maximum attenuation	ATT	Vo=1Vrms, (18,25)pin OUT JIS-A, Vol.= -∞			dB		
	Output noise voltage	Vono	JIS-A, At no signal, Rg=0Ω (18,25)pin OUT	Vol.=0dB	-	10.0	20.0	μVrms
				Vol.=∞	-	4.0	8	μVrms
	Distortion factor	Vrecono	JIS-A, At no signal, Rg=0Ω (8,35)pin OUT			μVrms		
		THD	BW:400-30kHz, Vo=0.5Vrms, RL=10kΩ			%		
		THDrec	BW:400-30kHz, Vo=0.5Vrms, RL=47kΩ			%		
	Cross talk between channels	CT	Vo.=0.5Vrms, RL=10kΩ, JIS-A, Rg=0kΩ			dB		
CT rec		Vo.=0.5Vrms, RL=47kΩ, JIS-A, Rg=0kΩ			dB			
Tone Control	Bass voltage gain	Gbassb	f=100kHz	-8dB	6	8	10	dB
		Gbassc		+8dB	-10	-8	6	dB
	Mid voltage gain	Gmidb	f=1kHz	-8dB	6	8	10	dB
		Gmidc		-8dB	-10	-8	6	dB
	Treble voltage gain	Gtrebb	f=10kHz	+8dB	-2	8	10	dB
		Gtrebc		-8dB	-10	-8	6	dB
Balance between channel	BALton	At each boost value of -8dB and +8dB Vo=1Vrms, (14,29)pin OUT			dB			
MIX Signal	Super woofa output gain	GvSW	Vi=1Vrms, FLAT, Gain from (3-18 pin) to (40-25 pin), Input ATT=0dB			dB		
	distortion factor	THDSW	BW:400-30kHz, Vo=0.3Vrms, RL=47kΩ 15pin IN, 24pin OUT			%		
	Output noise voltage	VnoSW	JIS-A, At no signal, Rg=0Ω, 24pin OUT			μVrms		
	Output gain for spectrum Analyzer Display	GvSP	Vi=1Vrms, FLAT, Input ATT=0dB, 3pin IN, 19pin OUT			dB		

•Mix Signal Characteristics is provided only CH1 Input.(CH2 Rg=0Ω)

FUNCTION DISCRIPTION

(1)Equivalent circuit of tone control

(a)Mid

Boost Mode

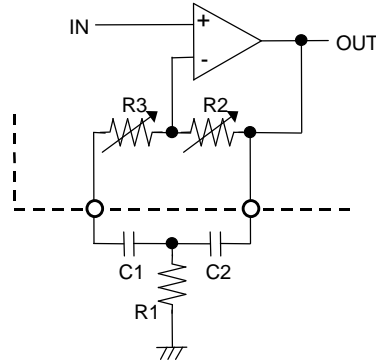

$$f_o = \frac{1}{2p\sqrt{R1(R2+R3)C1C2}} \text{ (Hz)}$$

$$Q \approx \frac{1}{C1+C2} \sqrt{\frac{C1C2R2}{R1}} \quad R3=0$$

$$G_v = 20\log \left[\frac{\frac{R2+R3}{R1} + 2}{\frac{R3}{R1} + 2} \right] \text{ (dB)} \quad (C1=C2)$$

Cut Mode

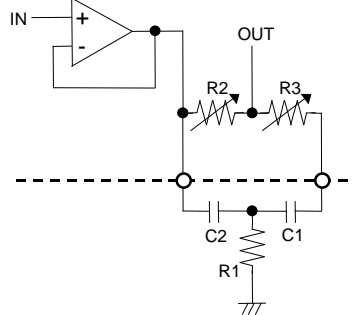

$$f_o = \frac{1}{2p\sqrt{R1(R2+R3)C1C2}} \text{ (Hz)}$$

$$Q \approx \frac{1}{C1+C2} \sqrt{\frac{C1C2R2}{R1}} \quad (R3=0)$$

$$G_v = 20\log \left[\frac{\frac{R3}{R1} + 2}{\frac{R2+R3}{R1} + 2} \right] \text{ (dB)} \quad (C1=C2)$$

(b)Bass

Boost Mode

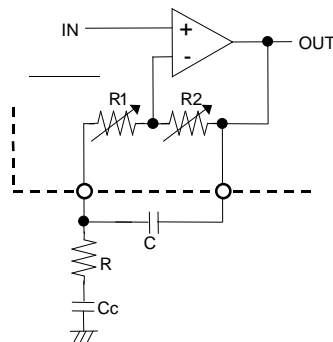

$$f_o = \frac{R+R1}{2pCR(R1+R2)} \text{ (Hz)}$$

$$G_v = 20\log \left[\frac{R+R1+R2}{R+R1} \right] \text{ (dB)}$$

Cut Mode

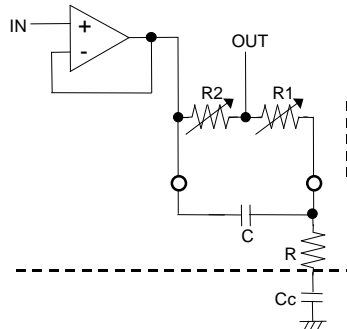

$$f_o = \frac{R+R1}{2pCR(R1+R2)} \text{ (Hz)}$$

$$G_v = 20\log \left[\frac{R+R1}{R+R1+R2} \right] \text{ (dB)}$$

(c) Treble

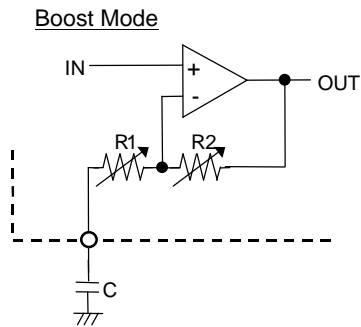

$$f_0 = \frac{1}{2\pi CR1} \text{ (Hz)}$$

$$G_v = 20\log \left[\frac{R1+R2}{R1} \right] \text{ (dB)}$$

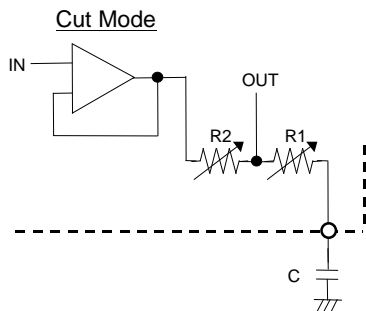

$$f_0 = \frac{1}{2\pi CR1} \text{ (Hz)}$$

$$G_v = 20\log \left[\frac{R1}{R1+R2} \right] \text{ (dB)}$$

(d) Characteristic Curve of Tone Control

Tone control setting= +8, -8dB (Bass, Mid, Treble)

This characteristic curve is as a result of circuit Simulation.

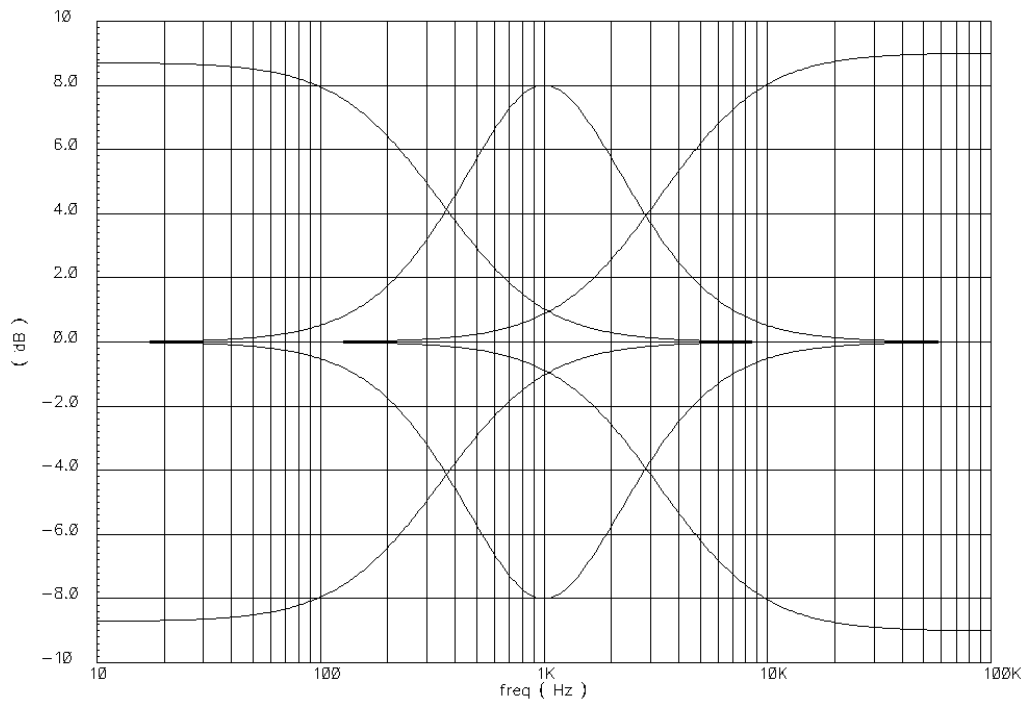

AUDIO SIGNAL PROCESSOR WITH SURROUND

(2)Equivalent circuit of bass boost

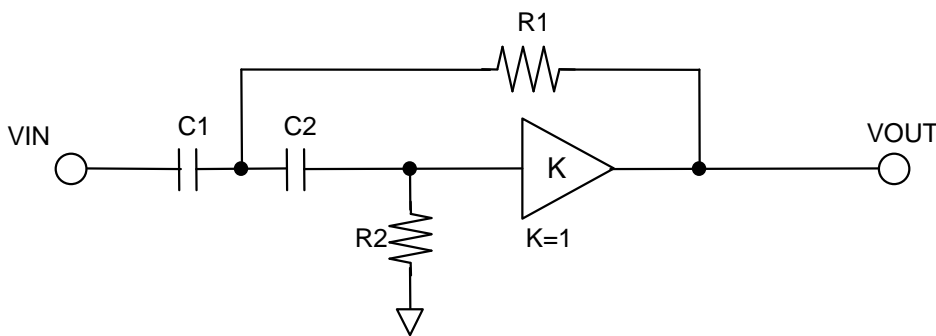
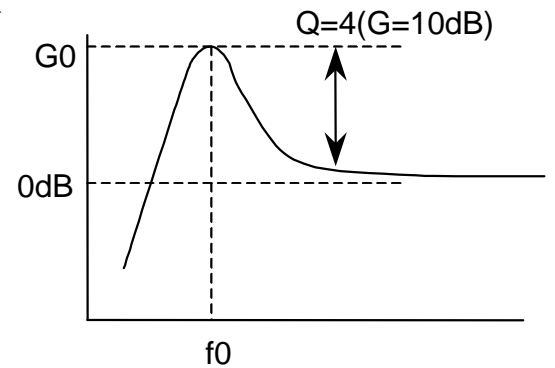
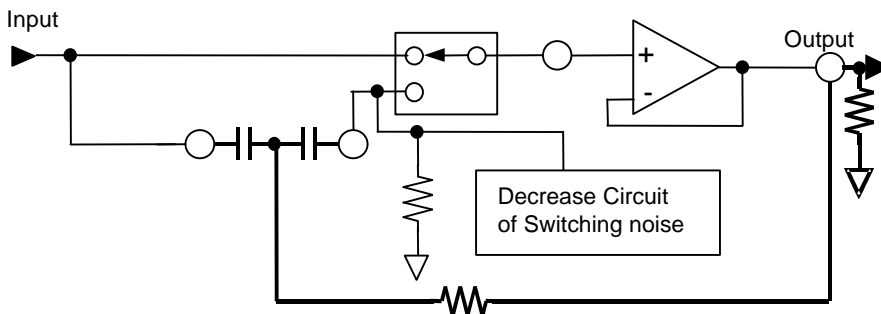

Reference Table

Q	G0
1	0 to 1dB
2	6dB
4	10dB
5	13dB
10	20dB

The Internal IC have built-in R2 resistance.(R2 = 214kΩ)

$$f_0 = \frac{1}{2\pi\sqrt{R_1R_2C_1C_2}} \text{ (Hz)} \quad Q = \frac{\sqrt{R_1R_2C_1C_2}}{R_1(C_1+C_2)+(1-K)R_2C_2}$$

Amplitude characteristic of secondary high pass filter

•Characteristic Curve of bass boost

R1=680Ω, R2=214kΩ, C1=C2=0.22μF (fo ≈ 60Hz, Q ≈ 8.9)

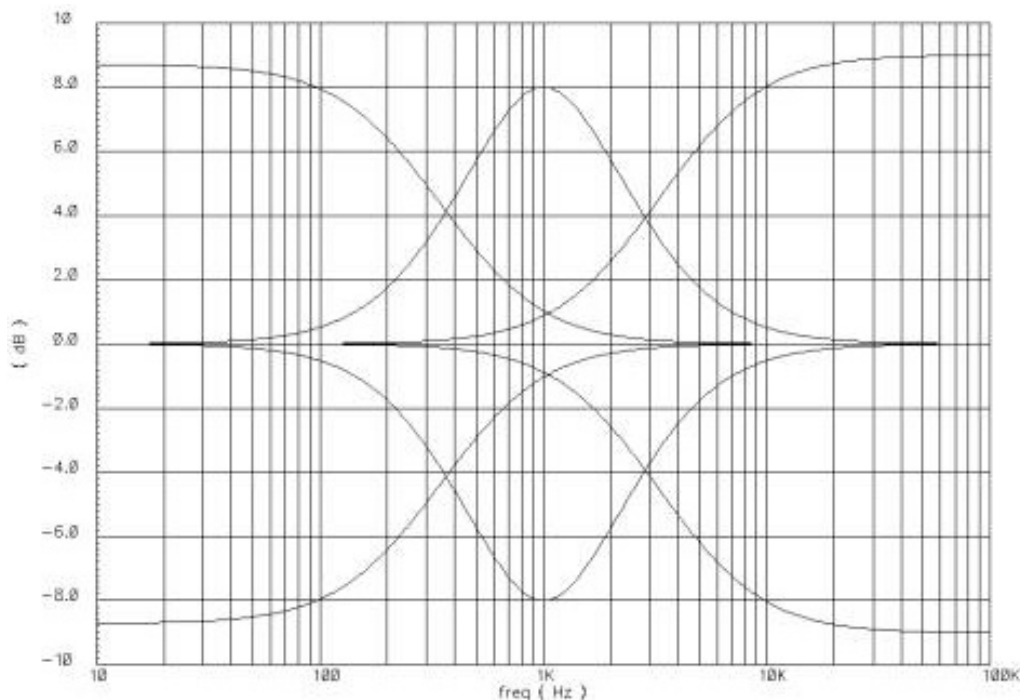

(3) Equivalent circuit of vocal cut

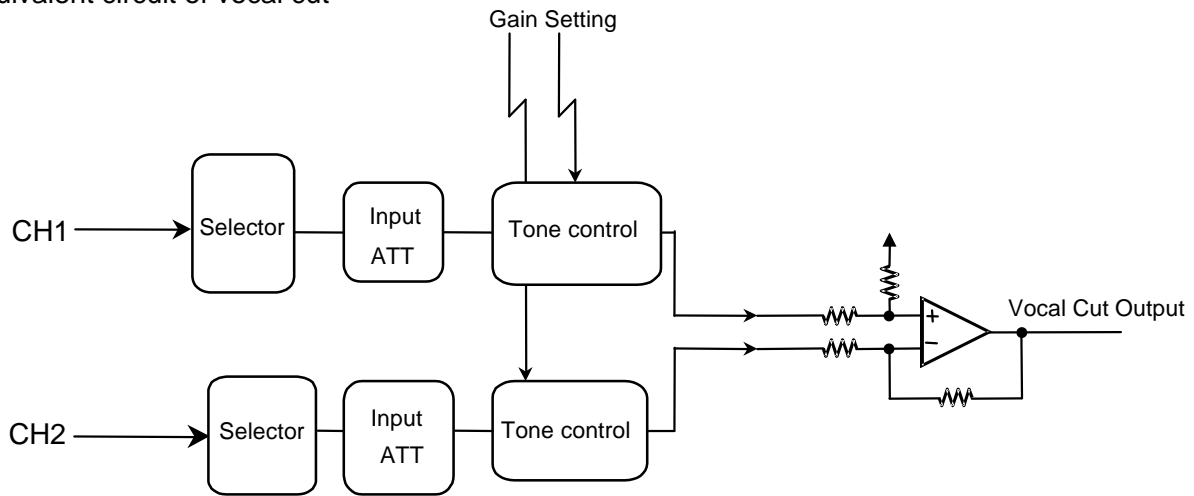

- Tone control cannot use at Vocal cut mode.
- Tone control can use only Bass & Treble mode.(Mid mode is 0dB fixed.)

Output difference of Tone control CH1 and CH2, The characteristic to cut only Middle part of Phase Input Signal is realized.

• Characteristic curve example (Phase signal input CH1,CH2)

- A; CH1 bass = +8dB, Treble = +8dB
CH2 bass = +4dB, Treble = +4dB
- B; CH1 bass = +8dB, Treble = +8dB
CH2 bass = +4dB, Treble = +6dB

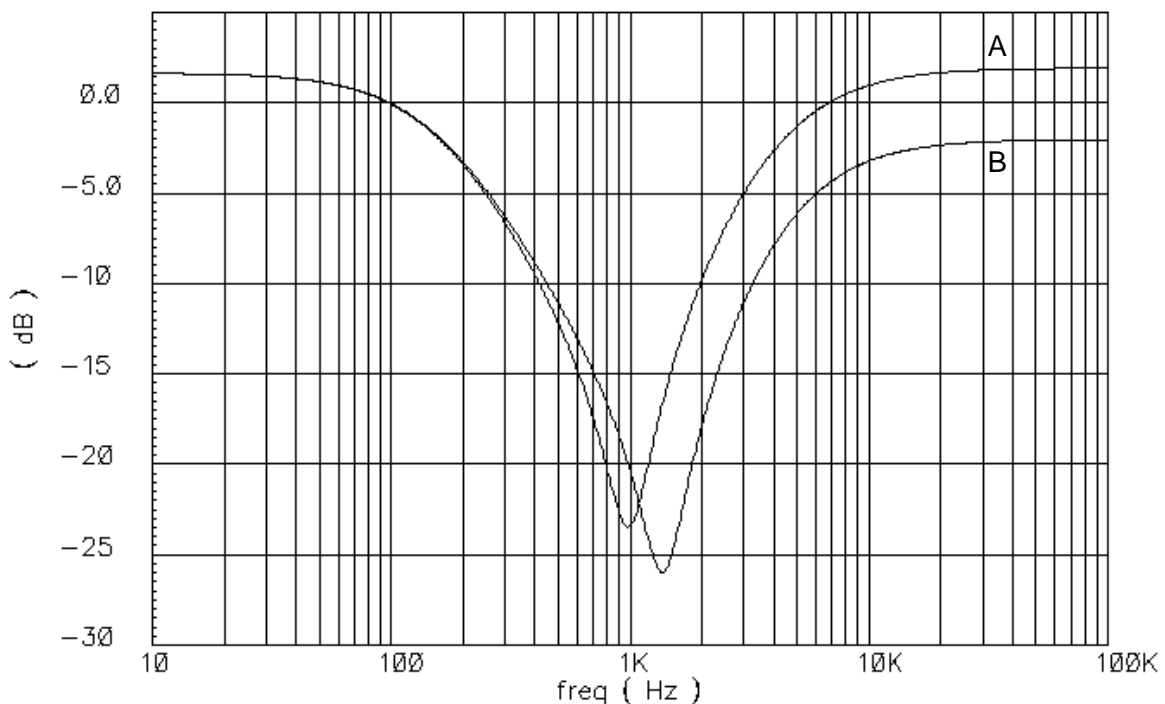

(4) Surround equivalent circuit

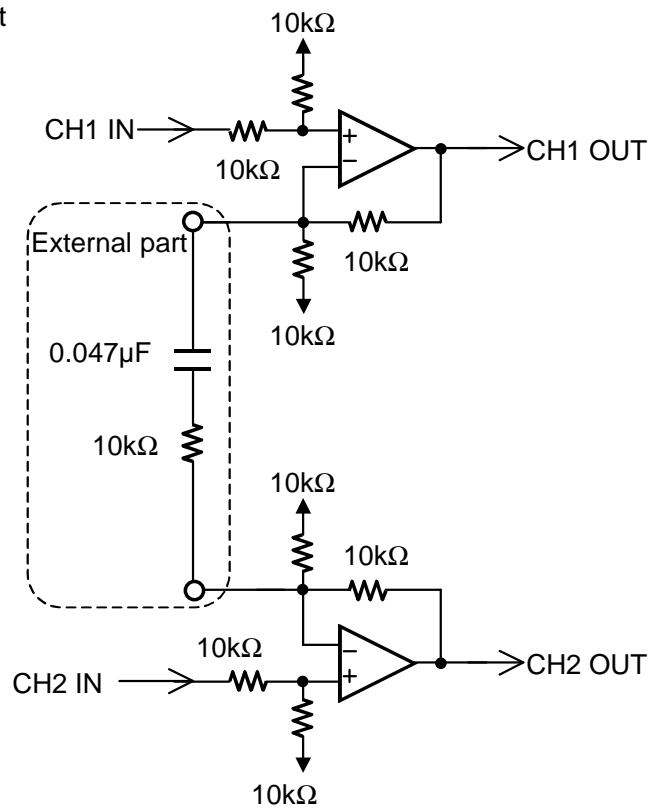

• Characteristic curve example (Only CH1 Input)

• This characteristic curve is the result as circuit simulation.

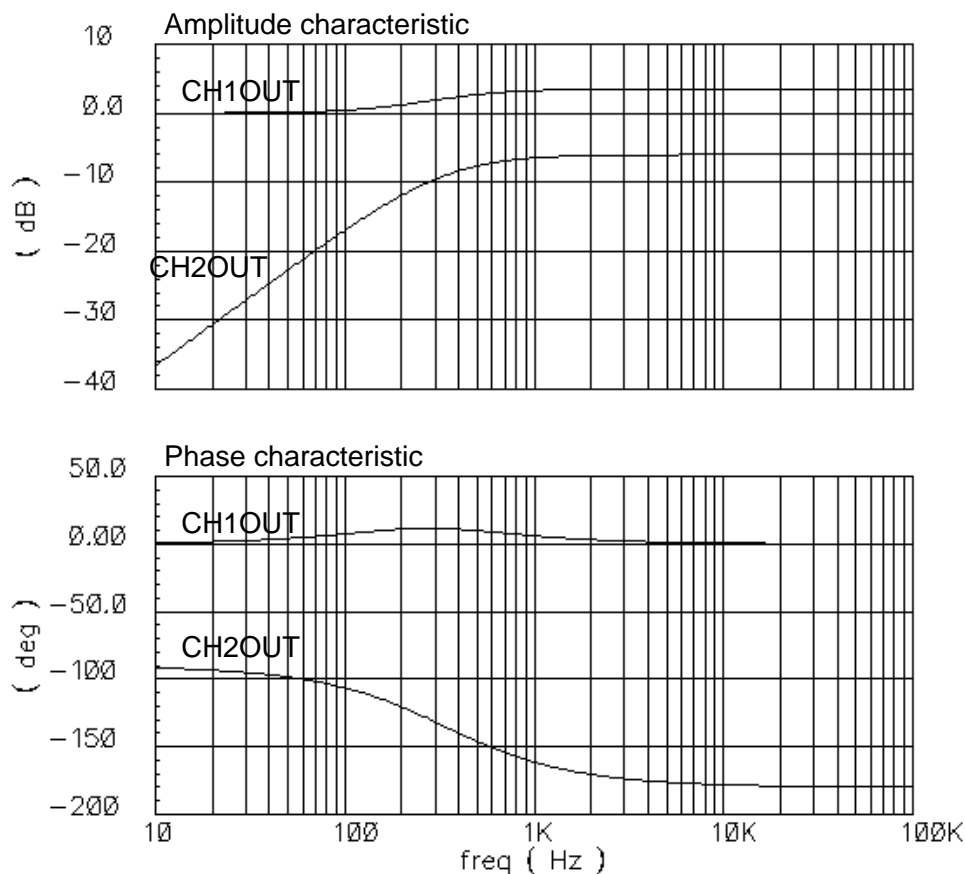

AUDIO SIGNAL PROCESSOR WITH SURROUND

(5) Total equivalent circuit (signal flow diagram)

(a) Surround bypass , Tone bypass , Bass boost ON

Maximum Output Voltage (Typ:2.0Vrms)

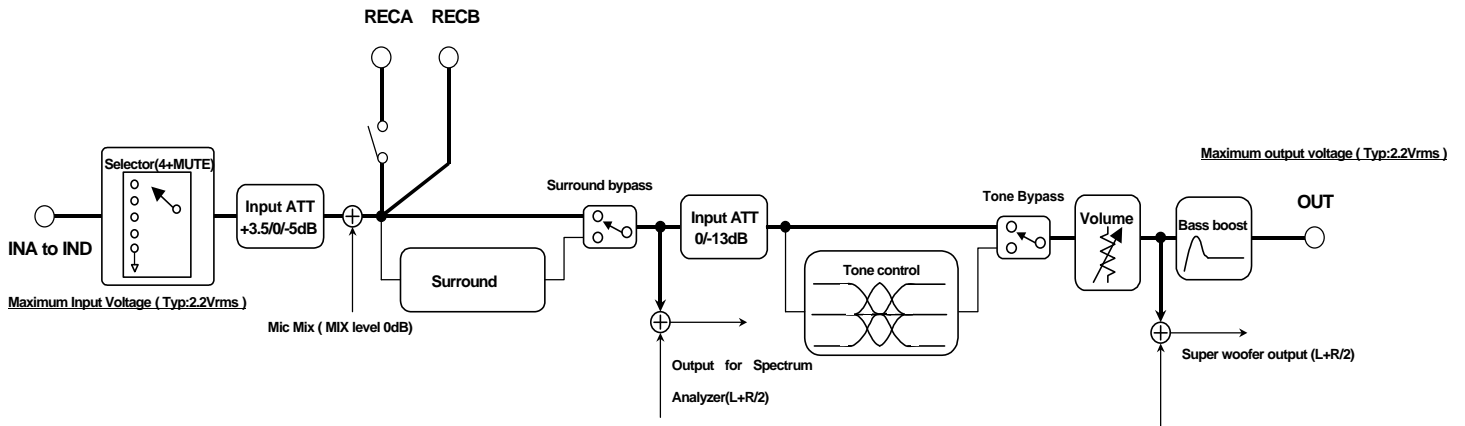

(b) Surround ON, Tone ON, Bass boost ON

Maximum Output Voltage(Typ:2.0Vrms)

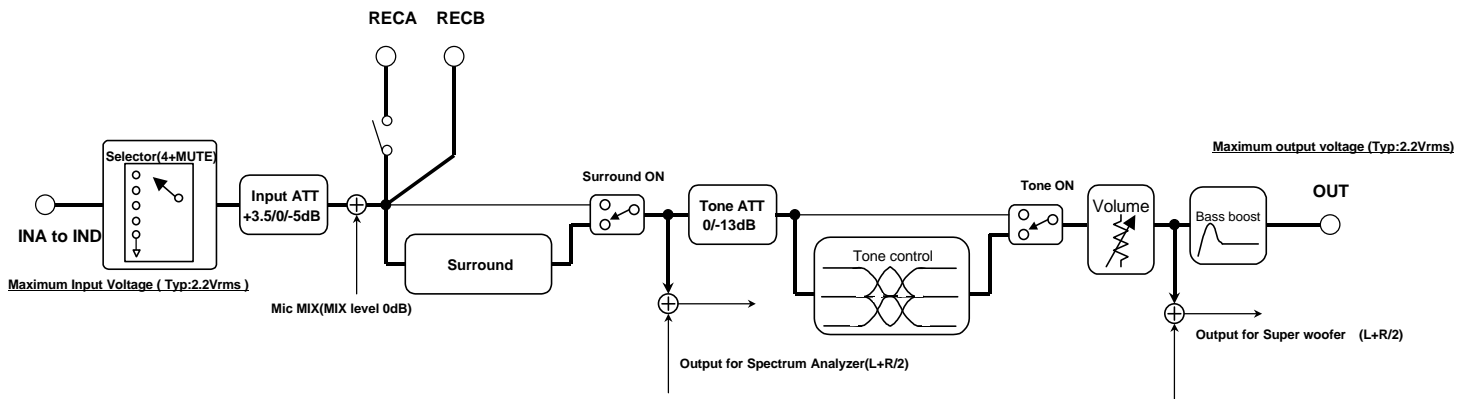

(c)DPL Input setting,Tone bypass, Bass boost ON

Maximum output voltage(Typ:2.0Vrms)

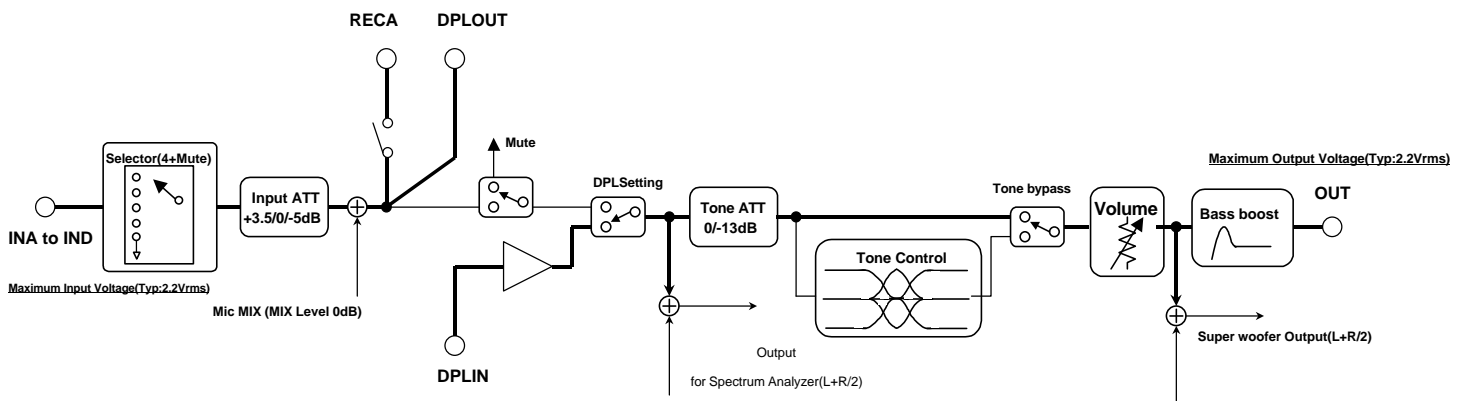

AUDIO SIGNAL PROCESSOR WITH SURROUND

(d) External Input Setting, Surround ON, Tone ON, Bass boost ON

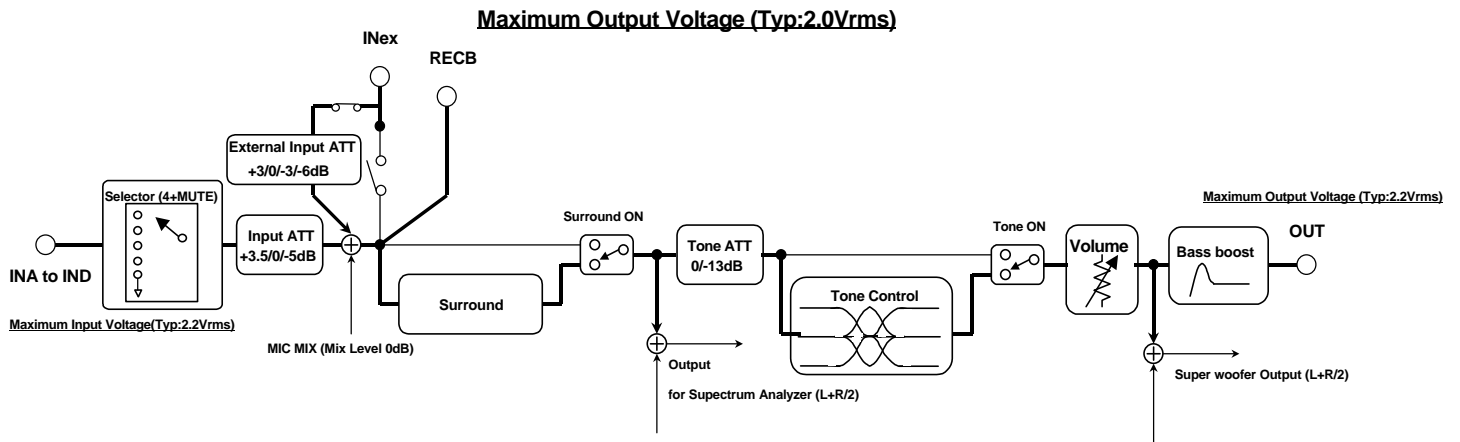

(e) Vocal Cut ON, Surround Bypass, Bass boost ON

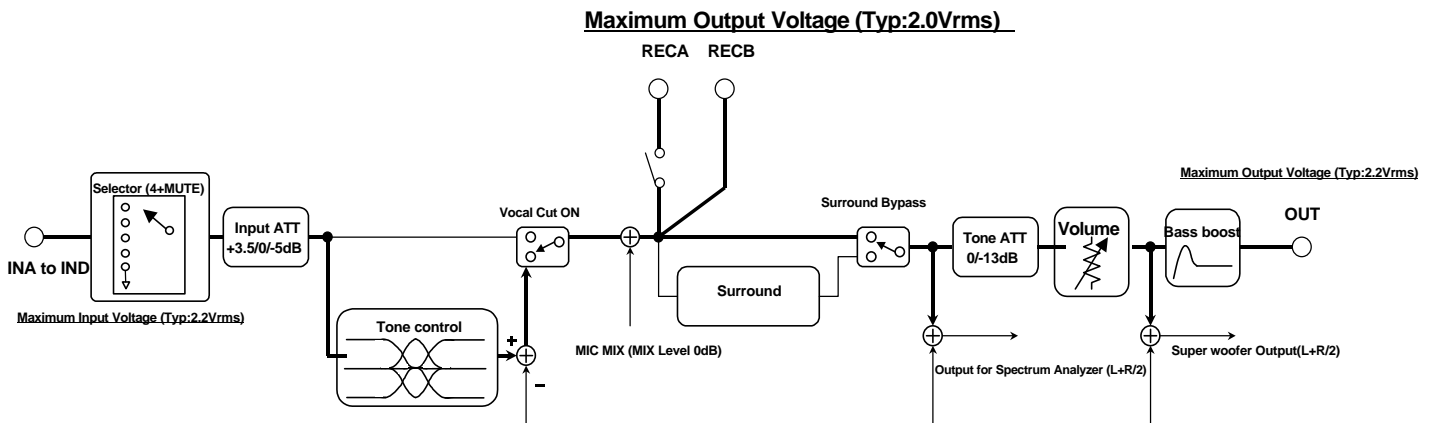

AUDIO SIGNAL PROCESSOR WITH SURROUND

APPLICATION EXAMPLE

SW1; A:Vocal Cut OFF
B:Vocal Cut ON

SW2; A:Surround
B:Corresponded to Dolby Pro Logic
C:Bypass

SW3; A:Vocal Cut OFF
B:Vocal Cut ON

At Input Dolby Pro Logic

SW4; A: Corresponded to Tone control
B:Corresponded to Vocal Cut and Tone bypass

SW5 A:Bass boost OFF
B:Bass boost ON

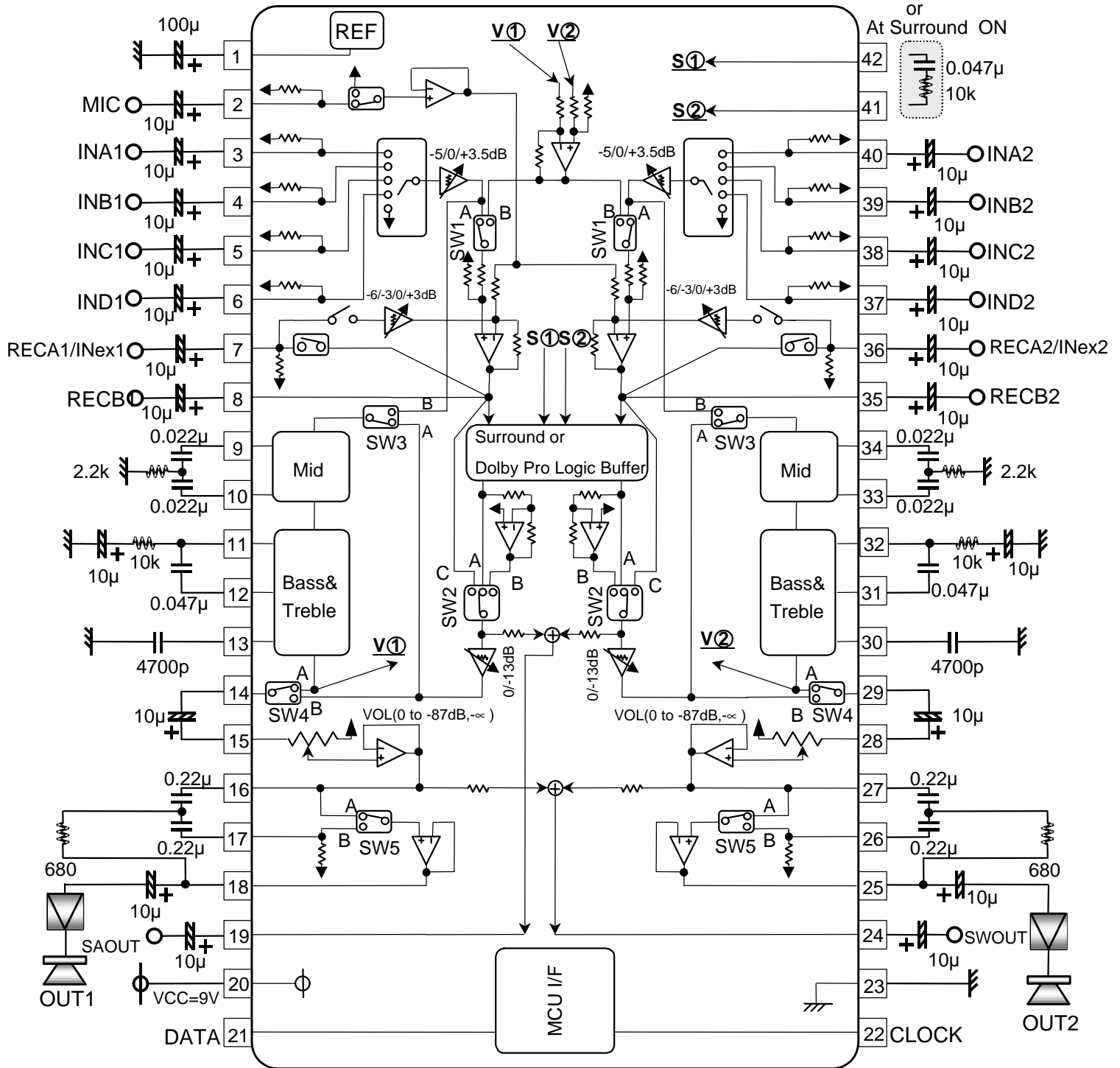
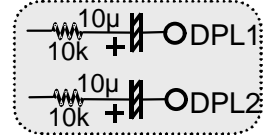

DETAILED DIAGRAM OF PACKAGE OUTLINE

42P2R-A (MMP) Plastic 42pin 450mil SSOP

EIAJ Package Code SSOP42-P-450-0.80	JEDEC Code -	Weight(g) 0.63	Lead Material Alloy 42/Cu Alloy
--	-----------------	-------------------	------------------------------------

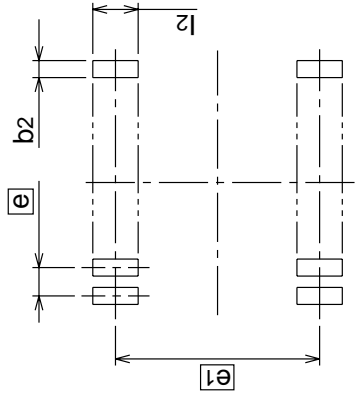
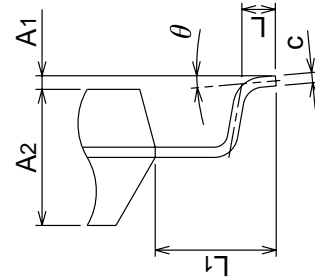
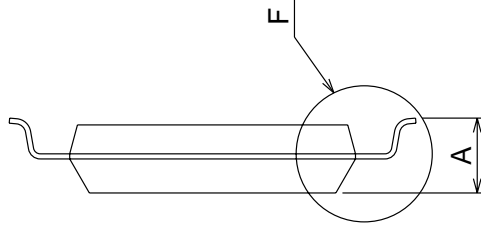
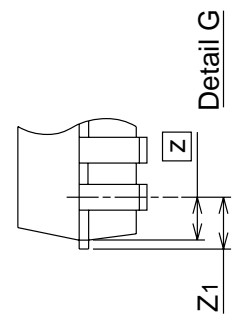
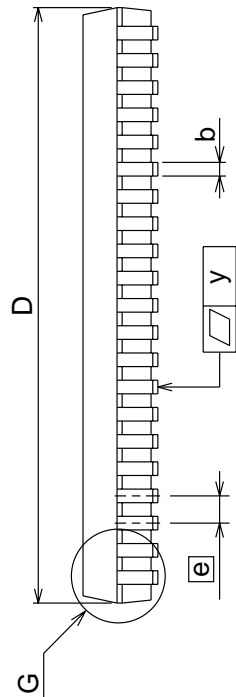
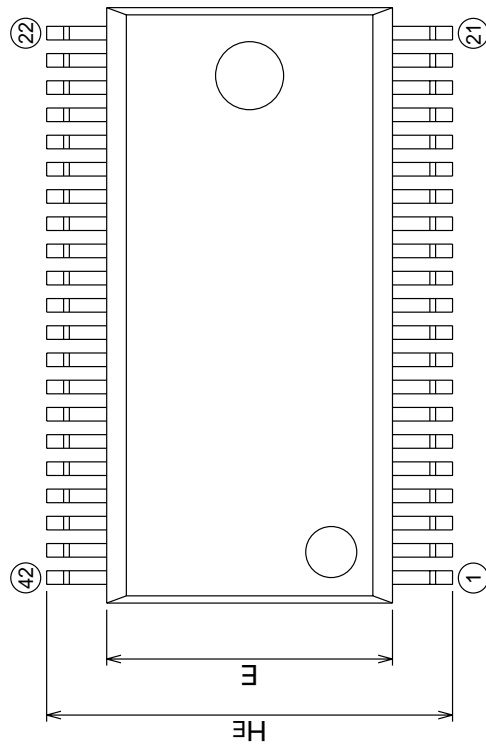

Recommended Mount Pad

Symbol	Dimension in Millimeters		
	Min	Nom	Max
A	-	-	2.4
A1	0.05	-	-
A2	-	2.0	-
b	0.35	0.4	0.5
c	0.13	0.15	0.2
D	17.3	17.5	17.7
E	8.2	8.4	8.6
e	-	0.8	-
HE	11.63	11.93	12.23
L	0.3	0.5	0.7
L1	-	1.765	-
z	-	0.75	-
Z1	-	-	0.9
y	-	-	0.15
theta	0°	-	10°
b2	-	0.5	-
e1	-	11.43	-
l2	1.27	-	-

Keep safety first in your circuit designs!

●Mitsubishi Electric Corporation puts the maximum effort into making semiconductor products better and more reliable, but there is always the possibility that trouble may occur with them. Trouble with semiconductors may lead to personal injury, fire or property damage. Remember to give due consideration to safety when making your circuit designs, with appropriate measures such as (i) placement of substitutive, auxiliary circuits, (ii) use of non-flammable material or (iii) prevention against any malfunction or mishap.

Notes regarding these materials

●These materials are intended as a reference to assist our customers in the selection of the Mitsubishi semiconductor product best suited to the customer's application; they do not convey any license under any intellectual property rights, or any other rights, belonging to Mitsubishi Electric Corporation or a third party.
●Mitsubishi Electric Corporation assumes no responsibility for any damage, or infringement of any third-party's rights, originating in the use of any product data, diagrams, charts, programs, algorithms, or circuit application examples contained in these materials.

●All information contained in these materials, including product data, diagrams, charts, programs and algorithms represents information on products at the time of publication of these materials, and are subject to change by Mitsubishi Electric Corporation without notice due to product improvements or other reasons. It is therefore recommended that customers contact Mitsubishi Electric Corporation or an authorized Mitsubishi Semiconductor product distributor for the latest product information before purchasing a product listed herein. The information described here may contain technical inaccuracies or typographical errors. Mitsubishi Electric Corporation assumes no responsibility for any damage, liability, or other loss rising from these inaccuracies or errors.

Please also pay attention to information published by Mitsubishi Electric Corporation by various means, including the Mitsubishi Semiconductor home page (<http://www.mitsubishichips.com>).

●When using any or all of the information contained in these materials, including product data, diagrams, charts, programs, and algorithms, please be sure to evaluate all information as a total system before making a final decision on the applicability of the information and products. Mitsubishi Electric Corporation assumes no responsibility for any damage, liability or other loss resulting from the information contained herein.

●Mitsubishi Electric Corporation semiconductors are not designed or manufactured for use in a device or system that is used under circumstances in which human life is potentially at stake. Please contact Mitsubishi Electric Corporation or an authorized Mitsubishi Semiconductor product distributor when considering the use of a product contained herein for any specific purposes, such as apparatus or systems for transportation, vehicular, medical, aerospace, nuclear, or undersea repeater use.

●The prior written approval of Mitsubishi Electric Corporation is necessary to reprint or reproduce in whole or in part these materials.

●If these products or technologies are subject to the Japanese export control restrictions, they must be exported under a license from the Japanese government and cannot be imported into a country other than the approved destination.

Any diversion or reexport contrary to the export control laws and regulations of Japan and/or the country of destination is prohibited.

●Please contact Mitsubishi Electric Corporation or an authorized Mitsubishi Semiconductor product distributor for further details on these materials or the products contained therein.